

QUICK START

This page helps you to get the phone up and running quickly. If you have not used a mobile phone before, we recommend that you read the chapter “*Preparing Your Phone for Use*” on page 4, for a more detailed installation procedure.

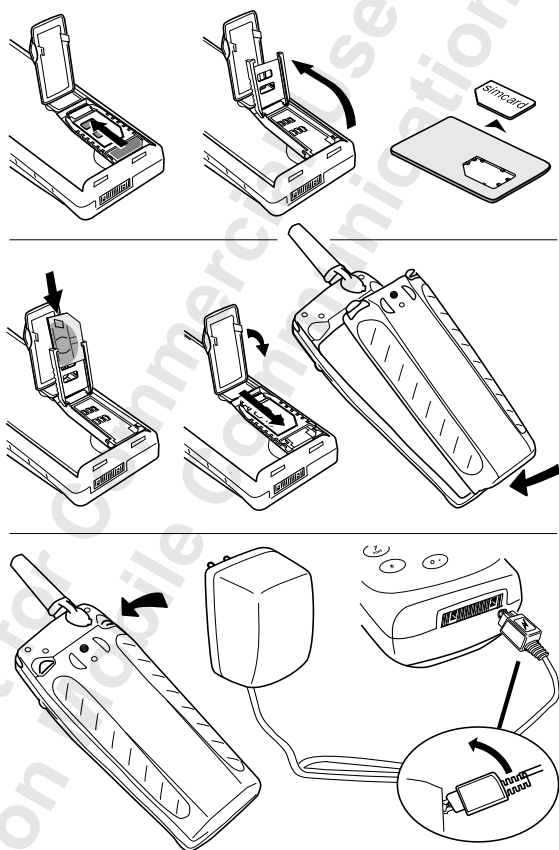

- Wash the phone gently in cold water under a water tap.
- Do not immerse the phone in water!

R250S PRO FEATURES

- The R250s PRO is a mobile phone, specially designed to be used when working outdoors. Thanks to its rugged design the R250s PRO is very resistant to external influences such as dust, rain and shock.
- The R250s PRO is the first mobile phone which supports GSM Pro. GSM Pro is an extended feature of the GSM network, which supports group calls and call monitoring. (GSM Pro requires a GSM Pro subscription.)
- The R250s PRO has an vibrating call alert, which means that the phone vibrates when you receive an incoming call or message. This is a useful function when you are working in a noisy environment, where you cannot hear the phone signal.
- When you work in a noisy environment, you can use Ericsson handsfree equipment in combination with ear protection equipment. At an incoming group call, the call is answered automatically and you will hear the conversation in the earpiece.
- Key pad lock. The key pad lock prevents accidental dialling, which could happen if you keep your phone attached to your belt. The key pad remains locked until you receive an incoming call. While the key pad is locked, you can still use the **Push-To-Talk button** on the left side of the phone for entering the phone book.
- **Alert button.** The R250s PRO is equipped with an alert button on the top of the phone, which makes it easy to call a pre-set alert number.



Note! Please read the chapter “Guidelines for Safe and Efficient Use” on page 112, before using your mobile phone.

Contents at a Glance

Getting Started 3

- Preparing Your Phone for Use 4
- Turning Your Phone On and Off 14
- Display Information and Key Functions 17
- Making and Receiving Calls 19
- During a Call 24
- Speakerphone 26

Functions and Settings 29

- Using the Menu System 30
- Your Personal Phone Book 33
- Keeping Track of Your Phone Calls 42
- Your Voice Mail Service 44
- Personalizing Your Phone 46
- Sending and Receiving Text Messages (SMS) 53
- Diverting Incoming Calls 62
- Security for Your Phone and Subscription 64
- Setting Network Preferences 70
- Handling More than One Call Simultaneously 74
- Knowing the Call Time/Call Cost 78
- Using Two Phone Lines 81
- Calling Card or Credit Card Calls 83
- Sending and Receiving Fax and Data calls 85
- Some Useful Tools 86

GSM Pro 89

- GSM Pro 90

Additional Information 97

- Accessories 98
- Troubleshooting 102
- Ericsson Mobile Internet 104
- Quick Keys 105
- Technical Data 106
- Glossary 107
- Guidelines for Safe and Efficient Use 112
- Warranty 116
- Declaration of Conformity 118
- Index 119

Ericsson R250s PRO

Third edition (June 2000)

This manual is published by **Ericsson Mobile Communications AB**, without any warranty. Improvements and changes to this manual necessitated by typographical errors, inaccuracies of current information, or improvements to programs and/or equipment, may be made by **Ericsson Mobile Communications AB** at any time and without notice. Such changes will, however, be incorporated into new editions of this manual.

All rights reserved.

©Ericsson Mobile Communications AB, 1999

Publication number: EN/LZT 108 2554 R1C
Printed in Sweden
INNOVATRON PATENTS

Please note!

Some of the services in this manual are not supported by all networks. *This also applies to the GSM International Emergency Number 112.*

Please contact your network operator or service provider if you are in doubt whether you can use a particular service or not.

The symbol on our products signifies that they have been certified according to the EMC directive 89/336/EEC, the Telecommunications directive 91/263/EEC, and the Low Voltage directive 73/23/EEC when applicable. The products fulfil the requirements according to the following standards:

Cellular Phones and Accessories in Combination:

ETS 300 342-1 EMC for European digital cellular telecommunications.

Accessories Without Direct Connection to a Cellular Phone:

EN 50081 Electromagnetic compatibility, Generic Emission Standard, and EN 50082 Electromagnetic compatibility, Generic Immunity Standard.

GETTING STARTED

Preparing Your Phone for Use	4
Turning Your Phone On and Off	14
Display Information and Key Functions	17
Making and Receiving Calls	19
During a Call	24
Speakerphone	26

Not for Commercial Use
Ericsson Mobile Communications AB

Preparing Your Phone for Use

Note! Please read the chapter “Guidelines for Safe and Efficient Use” on page 112, before using your mobile phone.

OVERVIEW

Front

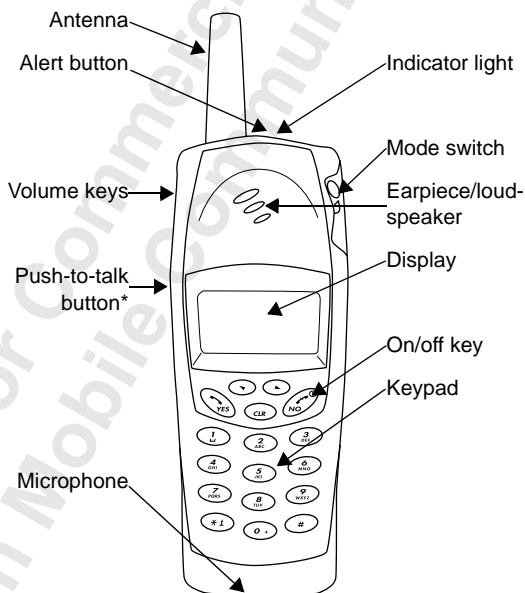

* If you are not using a SIM Pro card (see “GSM Pro” on page 90), i.e. if you are using a regular SIM card, pressing the Push-to-talk button mutes the microphone, if pressed during a conversation.

Top

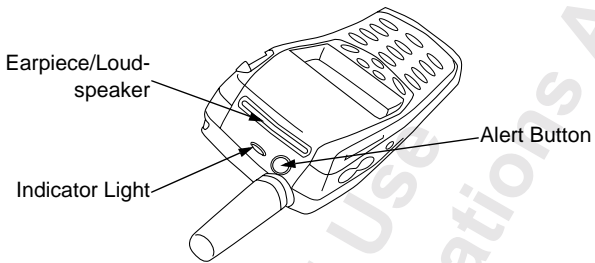

Back

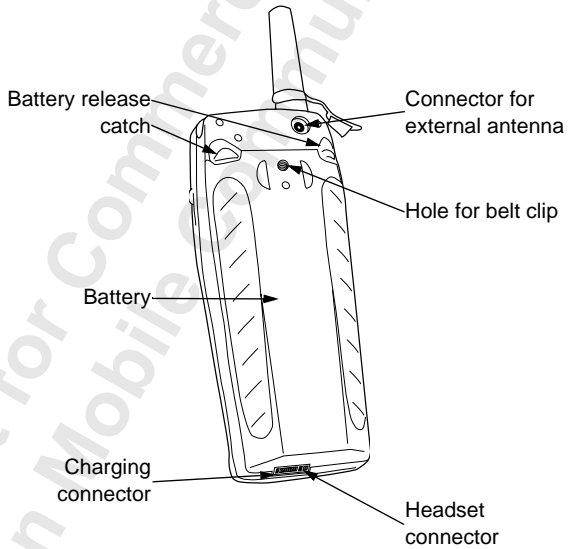

ASSEMBLY

To use your phone you must:

- insert the SIM card
- attach the battery to the phone
- charge the battery

Please see the following pages.

THE SIM CARD

When you register as a subscriber with a network operator, you get a SIM (Subscriber Identity Module) card. The SIM card contains a computer chip that keeps track of your phone number, the services included in your subscription, and your Phone Book information, among other things.

SIM cards come in two sizes. One is the size of a credit card, and the other is smaller. Your phone uses the smaller card. Many credit card-sized SIM cards have a perforated smaller card that you can take out easily. Before you can use your phone, you must insert the SIM card as shown below.

Inserting the SIM Card

To insert the SIM card, remove the battery (if attached) and follow these steps:

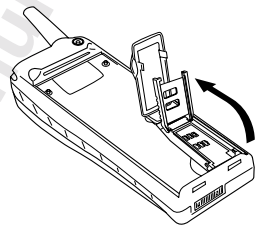
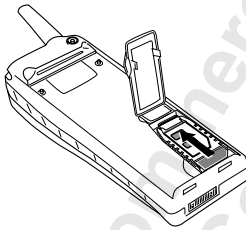

1. Open the lid that covers the SIM card holder.
2. Release the SIM card holder by sliding it in the direction of the arrow.
3. Open the holder.

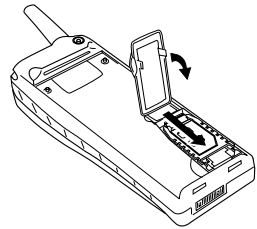
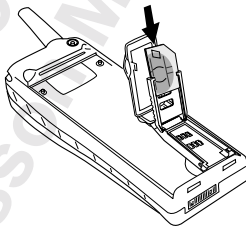

4. Slide the SIM card into the holder. Make certain that the cut corner is in the top right-hand corner.
5. Lock the holder by pressing it down and sliding it in the direction of the arrow in the picture.
6. Finally, close the lid.



Enter
PIN

The PIN

Most SIM cards are supplied with a security code or PIN (Personal Identity Number), which you need to access the network. Every time you turn on your phone, it prompts you to enter your PIN. You will find your PIN in the information from your operator.

You may need your PIN when you want to change the settings in your phone. Furthermore, some operators may have services that require a second PIN, your PIN2.

You should be careful with your PIN, since it is your protection against unauthorized use of your subscription.

If your PIN is entered incorrectly three times in a row, the SIM card is blocked. If this happens, you can unlock it by using your PUK (Personal Unblocking Key code), which you also get from your operator.

THE BATTERY

The R250s PRO comes with a nickel metal hydride (NiMH) battery. The battery is not charged when you buy your phone, but there may be enough power to turn the phone on. We recommend that you charge the battery before you use the phone for the first time.

The battery is specially designed for the R250s PRO. The battery has a special locking mechanism that prevents it from falling off if you should drop the phone on the ground.

The battery is equipped with a special rubber sealing to prevent leakage into the phone. With the battery and antenna properly attached, the phone is dust- and water-resistant. The phone can be used outdoors, even if it is raining and the phone will not be damaged if you use it in a dusty environment.

Use only Ericsson original batteries. By using other batteries you risk damaging the phone and will void the warranty.

Attaching the Battery

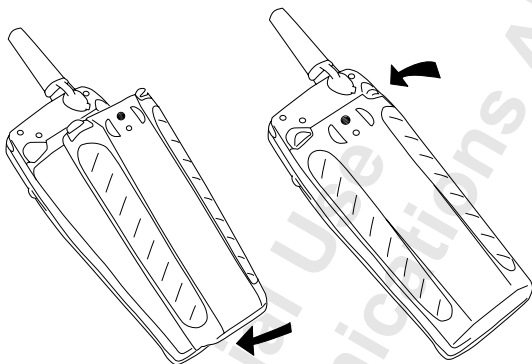

1. Attach the battery to the bottom part of the phone.
2. Press the upper part of the battery against the phone until you hear two clicks.

When to Charge the Battery

The nickel metal hydride battery that comes with your phone can be charged whenever you wish without affecting its performance. This is not the case with the cheaper nickel cadmium type batteries, often sold as accessories by other suppliers. For the best talk and standby time in the long run, we recommend that you use only Ericsson original batteries with your phone.

Note! *If you charge a new battery, or a battery that has not been used for a long time, it may take a while until you get an indication of charging.*

To remind you that you will soon need to charge the battery or replace it with a charged one:

- an alarm signal (a long beep) sounds and the message **Battery low** appears for ten seconds in the display. The signal is repeated several times.
- the indicator light on top of the phone starts flashing red.

Note! *The phone turns itself off when the battery can no longer power it satisfactorily.*

Charging the Battery

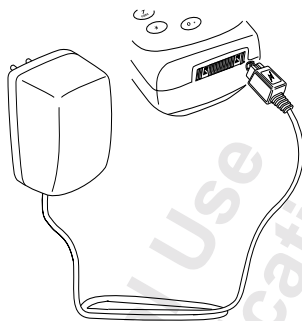

1. Make sure that the battery is attached to the phone.
2. Connect the charger to the mains.
3. Connect the other end of the cable to the phone as shown in the picture. The flash symbol on the plug must face upwards.

To indicate charging:

- the battery meter in the display pulses continuously.
- the indicator on top of the phone shows a steady red light (or green, if the phone is turned on).

When the battery is fully charged, the battery meter in the display is full and the indicator on top of the phone shows a steady green light.

Tip! You can use the phone while the battery is being charged. However, this increases the charging time.

You can also connect the charger to the desk/wall stand that comes in your box. Just place the phone in the desk/wall stand when you need to charge the phone. See "Desk/Wall Stand" on page 99 for more information.

Disconnecting the Charger

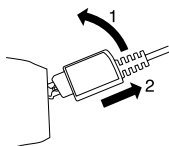

- Push the plug connected to the phone upwards and pull it out.
- Attach the rubber protector to the system connector.

Removing the Battery

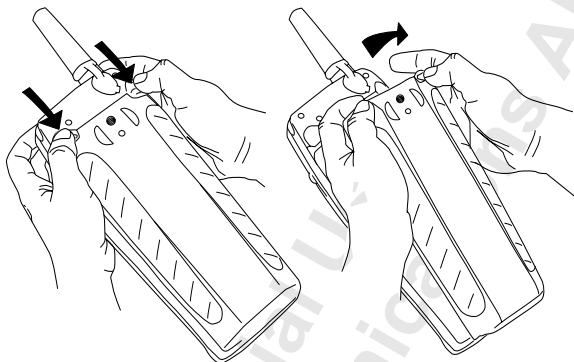

1. Turn off the phone.
2. Press the battery release catch on the top of the battery.
3. Lift the battery up and away from the phone.

Switching Antennas

The R250s PRO comes with two antennas. The longer antenna gives you better receiving signalling when you are within an area with poor radio coverage. Please make sure that you switch antennas during dry conditions, to prevent leakage into the phone.

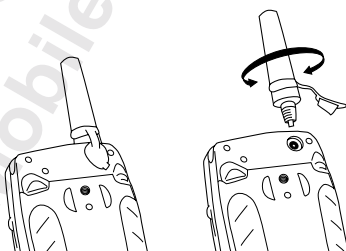

1. Pull out the rubber plug from the external antenna connector.
2. Screw the antenna anti-clockwise to remove it.
3. Attach the new antenna, screwing it clockwise until it is properly attached.
4. Insert the rubber plug into the external antenna connector.

Note! Do not use any antennas designed for other type of telephone. The antenna is specially designed for the R250s PRO. With the antenna (and battery) properly attached the phone is water resistant. Using other antennas will void the warranty.

The Clips

The R250s PRO comes with two different clips:

- standard clip
- swivel clip.

The standard clip is a metal belt clip which is attached to the battery with a screw.

The swivel clip is a belt holder which has a knob and a belt holder. The knob is attached to the battery with a screw. The knob is round to allow the phone to rotate in the holder. To prevent the phone from falling out of the clip, you need to press a button to release the phone.

Attaching the Swivel Clip

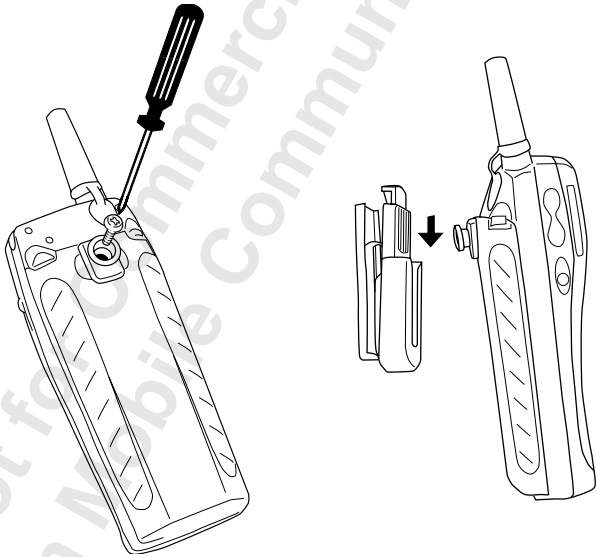

1. Attach the knob to the battery.
2. Slide the phone downwards until it locks.
3. To release the phone from the belt holder: press and hold the release button and pull the phone upwards.

SYSTEM CONNECTOR BOOT

The system connector boot prevents connected accessories, e.g. a handsfree set from falling out. When you use a portable handsfree and the phone is attached to your belt, the handsfree will not fall out if you bend forward or sit down.

The system connector boot also works as protection for the phone's system connector. With the system connector boot attached, you can charge the phone outdoors, even if it is raining, or in a dusty environment without damaging the phone's system connector.

System Connector boot

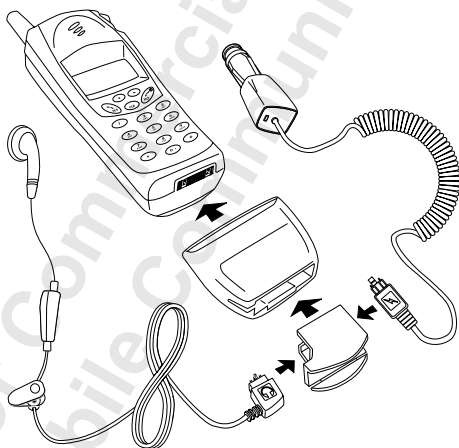

1. Insert the handsfree plug or the charger plug (or both) as shown in the picture above. The flash and the headset symbol must face upwards.
2. Pull the insert part of the system connector boot through the system connector boot and attach it to the phone's system connector, as shown in the picture to the right.
3. Pull the system connector boot over the insert part and the phone, until it is properly attached.
4. To release the System connector boot from the phone, push it upwards and pull it out.

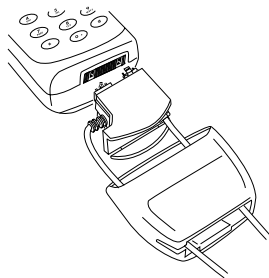

TAKING CARE OF YOUR MOBILE PHONE

When needed, the phone can be washed under running water. We recommend that you do it gently in cold water under a water tap. Before washing the phone, it is important that the battery is properly connected, the antenna is properly screwed on and that all accessories are removed.

Washing the Phone

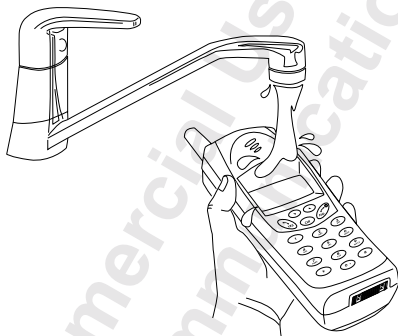

- Wash the phone gently in cold water under a water tap.
- Do not immerse the phone in water!

Note! When washing your phone, do not direct the jet of water towards the buzzer or the microphone.

Buzzer



Microphone

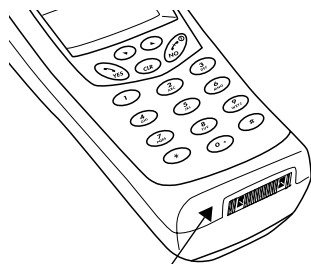

Turning Your Phone On and Off

TURNING YOUR PHONE ON

- Press and hold the **NO** key until you hear a click.

If Enter PIN Appears in Display

Some SIM cards are protected with a PIN code. If **Enter PIN** appears in the display after you have turned on the phone:

1. Enter your PIN. If you make a mistake while entering your PIN, erase the wrong digit by pressing the **CLR** key.
2. Press **#** or **YES** to confirm your PIN code.

Note! If your PIN is entered incorrectly three times in a row, the SIM card is blocked. You can unblock it by using your PUK code, which is supplied by your operator. See “Security for Your Phone and Subscription” on page 64.

Network Search

After you have turned on the phone (and entered your PIN), the Ericsson name appears in the display and the phone searches for a network.

When a network has been found, the phone beeps three times. The indicator light on the top of the phone flashes green once every second and your network operator’s name (in most cases abbreviated) appears in the display. This is called **standby mode**. You can now make and receive calls.

IF NO NETWORK IS DISPLAYED

Normally, the name of a network appears in the display after you have turned your phone on, but sometimes there is no network within range that you can use. The display then shows one of the following:

Searching

If the message **Searching** remains in the display, you are within range of a network, but you are not allowed to use it. However, in an emergency, some operators allow you to call the international emergency number 112. See “Making and Receiving Calls” on page 19.

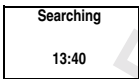
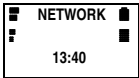
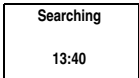
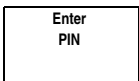

No network

13:40

No Network

If the message **No network** is displayed, there is no network within range or the received signal is too weak. You have to move to get a stronger signal. You can also try to replace the antenna with the longer high gain antenna.

INITIAL SETTINGS

The first time you turn on your phone, you may want to change the language in the display, set the clock and choose the ring signal type. For more information about these settings, see “*Personalizing Your Phone*” on page 46.

Display Language

Most modern SIM cards automatically set the display language to the language of the country where you bought your SIM card. If this is not the case, the default language is English.

If your phone displays a language that you do not understand, you can change it to English at any time. For more information on how to change the display language, see “*Display Language*” on page 46.

To change the language to English

1. Press the **CLR** key.
2. Press the **LEFT** arrow key.
3. Enter **0000**.
4. Press the **RIGHT** arrow key.

For information about the keys, please see “*Key Functions*” on page 18.

Setting the Time

The time is shown at the bottom of the display. When you buy your phone, the time is not normally set.

To set the time

1. Press the **LEFT** or **RIGHT** arrow key until the **Clock** menu appears.
2. Press **YES** to enter the clock menu.
3. Press the **RIGHT** arrow key until **Set clock** appears.
4. Press **YES** to enter the Set clock function.
5. Enter the correct time in hours and minutes, using the number keys.
6. Press **YES** to confirm your choice.
7. Press **CLR** to return to standby mode.

Note! *The time is by default presented in the 24-hour format. If you prefer the 12-hour format, you can change the setting.*

MENU

◀ Clock ▶

CLOCK

◀ Set Clock ▶
(14:16)

SET CLOCK

(14:16)
--:--

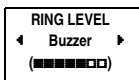
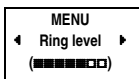

Setting the Ring Signal Level

1. Press the **RIGHT** arrow key.
The text **Ring level** and a bar representing the ring signal level appears in the display.
2. Press **YES** to enter the Ring level menu.
The text **Buzzer** appears in the display.
3. Press **YES** to enter the Buzzer menu.
4. Use the **RIGHT** and **LEFT** arrow keys to set the ring signal level.
 - Pressing the **RIGHT** key increases the volume.
 - Pressing the **LEFT** key decreases the volume.The phone rings once with the actual setting as you increase the volume, except for the "Off" and "Step" setting.
5. Press **YES** to save your setting.
6. Press **CLR** to return to standby mode.

TURNING YOUR PHONE OFF

- In standby mode, press and hold the **NO** key until you hear a click.

Display Information and Key Functions

DISPLAY INFORMATION

Your phone display helps you to:

- make sure that you are dialling correctly
- check your signal strength and service availability
- find out if you have received messages
- check which line is in use if you have the Two Line Service
- check battery level

Icons in the Display

Icons are displayed when specific functions are active or if you have received a message. The figure in the margin shows an overview of all the possible icons and where they appear.

The table below shows every icon separately and also gives you an explanation.

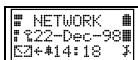

Icon:	Name:	Description:
	Signal strength meter	The strength of the received signal is indicated in steps. Four steps indicate the strongest signal.
	Battery meter	The fuller the icon, the more power there is.
	Keypad lock indicator	The keypad is locked.
	Divert indicator	An arrow means that the Divert all function is on.
	Silent ring signal	A crossed note means that no sound can be heard when you receive a call.
	SMS indicator	The envelope icon means that you have received a text message.
	Voice mail indicator	The tape loops mean that you have received a voice message.
	Alarm indicator	The bell shows that the alarm clock has been set and is on.

Icon:	Name:	Description:
L1/L2	Line indicator	Tells you which line is in use if you have the Two Line Service.
☒	Fixed incoming calls indicator	This icon indicates that fixed incoming calls is activated.

KEY FUNCTIONS

Before making or receiving a call, it is useful to understand the keys. The table below explains the basic key functions.

Note! Some keys have different functions when you enter the menu system. See "Using the Menu System" on page 30.

Key:	Use:
YES	To make and answer calls.
NO	To turn the phone on or off (press and hold the key). To end or reject a call.
LEFT and RIGHT arrow keys	To access and move (scroll) through the menu system.
CLR (Clear)	To erase digits from the display. Press and hold the key to erase all digits. To mute the microphone, press and hold the key.
Number keys	To enter the digits 0-9. The 0 key enters the international (+) sign if held down.
Star	To enter a star (*) character. If held down it enters a "p" – pause.
Hash	To enter #. To complete the input of PIN and security codes. If held down it enters the character □.
Volume keys UP and DOWN	To increase or decrease the volume of the earpiece or handsfree loudspeaker. To reject a call, press the volume keys up or down twice.
Mode switch	GSM: To switch between phone and speakerphone mode. If slide is up the phone is in speakerphone mode; if slide is down the phone is in phone mode. GSM Pro: To switch between phone and "Push-To-Talk" mode. If slide is up, the phone is in Push-To-Talk mode; if slide is down, the phone is in phone mode.
Push-to-talk button	In standby: to enter and scroll in Phone Book menu. GSM: Push this button to mute the microphone. GSM Pro: Push-to-talk mode, press this button to open microphone. Phone mode, press this button to mute the microphone.
Alert button	To make alert calls. Press and hold the alert button.

Making and Receiving Calls

The instructions in this chapter assume that you have turned on your phone and that you are within range of a network. If you are abroad, you may use other networks, provided your home network has an agreement that allows you to do this. See “*Setting Network Preferences*” on page 70.

Key Functions

Before making and receiving calls, it is useful to understand the keys and their functions. See “*Display Information and Key Functions*” on page 17.

MAKING A CALL

1. Enter the phone number, including the area code.

The digits are shown in the display. If you need to erase a digit, press **CLR**.

To erase all digits, press and hold the **CLR** key until all digits have been erased.

2. Press **YES** to make the call.

The display shows **Calling**, followed by **Connecting**.

3. Press **NO** when you want to end the call.

While a call is in progress, a call time meter in the display shows how long you have been on the phone in minutes and seconds. If you have turned on the Call cost option and your network supports it, you see the price of the call in the display. See “*Knowing the Call Time/Call Cost*” on page 78.

When you end the call the Call time meter shows the duration of the call for three seconds.

Tip! *It is possible to check the duration of the call later on. See “*Knowing the Call Time/Call Cost*” on page 78.*

No Answer

If nobody answers your call or you cannot get through press **NO**. The number is stored in a memory which makes it easy to repeat the call.

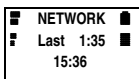
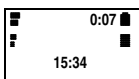
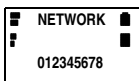

RE-DIALLING A PREVIOUSLY CALLED NUMBER

Your phone conveniently lets you re-dial the last phone numbers you have called (15 or more, depending on your SIM card). It can also re-dial a number automatically if the connection failed when you first called.

To re-dial a previously called number

1. Press **YES**.

The display shows the last dialled number.

2. Scroll with the **LEFT** and **RIGHT** arrow keys until you find the number you want to call.
3. Press **YES** to make the call.

Automatic Re-dialling

If the connection fails and the receiver's network supports it, the display shows **Retry?** on the top row and the reason for the failure on the second row.

To re-dial the number automatically

- Press **YES** when the message **Retry?** appears in the display.

The number is automatically re-dialled, up to 10 times:

- until the call is answered. If the re-dialling is successful, the phone beeps and then you hear a ring signal.
- until you press a key or receive a call.
- If you do not want to retry, press **NO**.

Note! *Automatic retry is not available for fax and data calls.*

MAKING INTERNATIONAL CALLS

1. Press and hold the **0** key until **+** is displayed.

The **+** automatically replaces the international dialling prefix for the country you are calling from.

2. Enter the country code, the area code (without the leading zero) and the phone number.
3. Press **YES** to make the call.

Note! *When you are abroad, your phone automatically searches for a network that you are allowed to use. Which networks you can use depends on the agreements your operator has signed with the operators in the country you are visiting. See "Setting Network Preferences" on page 70.*

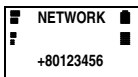

Checking the First Characters

If you have entered more characters than can be seen in the display, the first characters are replaced by the ✕ symbol. Press the **RIGHT** arrow key to check the first characters.

MAKING ALERT CALLS

The R250s PRO is equipped with an **Alert button**, located on the top of the phone, next to the antenna (see “*Overview*” on page 4). The alert button makes it easy to set up a call to a pre-set alert number, without having to enter the number manually.

When you buy your phone the alert number (when using the Alert button) is set to the international emergency number 112. This number can be changed, if you prefer to use another alert number. For more information on how to change the pre-set alert number, see “*Personalizing Your Phone*” on page 46.

Note! *If you change the pre-set alert number (112), you must insert a SIM card and enter the PIN code (if the card is locked). Otherwise the pre-set alert number (112) will be dialled and not the number you have specified.*

To make an alert call the alert button must be switched on. When you buy your phone the alert button is set to on. The alert button must be held down for 1 second, before a call is set up. This is to avoid accidental dialling if you press the button by mistake.

To make an alert call using the Alert button

1. Press and hold the **ALERT BUTTON**.

The call is set up and the number dialled is shown in the display. (The pre-set number is the international emergency number 112.)

2. Press **NO** to end the call.

Making Emergency Calls

You can also make an emergency call by entering the number in the same way as when making an ordinary call.

To make an emergency call

1. Enter 112 (the international emergency number).
2. Press **YES**.

The display shows **Emergency**.

3. Press **NO** to end the call.

Note! *Some Network operators may require that a SIM card has been inserted into the phone and, in some cases, that the PIN has been entered as well. Some networks may not use the international emergency number 112.*

Answer?

RECEIVING A CALL

When you receive a call, the phone rings and the indicator light on top of the phone blinks green rapidly. The display shows **Answer?**.

If your subscription includes the Calling Line Identification service and the caller's network sends the number, you see the caller's number at the bottom of the display. If the number is stored with a name in the phone book, the name is shown in the display.

Note! *The phone must be turned on and within range of a network before a call can be received.*

Answering a Call

- Press **YES** to answer the call.
- When the call is finished, press **NO**.

Rejecting a Call

There are two ways of rejecting a call:

- Press the **NO** key.
- Double click the volume key (up or down) on the side of the phone.

The caller hears a busy tone if the caller's network supports this function.

If "Divert on busy" is on, the incoming call is diverted to the number you have specified. See "*Diverting Incoming Calls*" on page 62.

Tip! *To mute the ring signal when you receive a call, press CLR.*

HIDING OR SHOWING YOUR NUMBER

With most common subscriptions, the caller's number is sent when a call is made. This means that the receiver can see your phone number when you make a call. However, some operators offer subscriptions where your phone number is normally hidden.

If you want to change the setting for a particular call, this is possible provided the network you use supports it.

To hide your phone number for a particular call

1. Enter the phone number you wish to call.
2. Press the **RIGHT** key.

The **Special functions** menu appears in the display.

3. Press **YES** to enter the Special functions menu.
4. Select **Hide Id** and press **YES** to make the call.



MENU
Special
functions

SPECIAL FUNC
Hide ID
01234567890

MENU
Special
Functions

SPECIAL FUNC
Send ID
01234567890

To Show Your Number for a Particular Call

1. Enter the phone number you wish to call.
2. Press the **RIGHT** key.

The **Special functions** menu appears in the display.

3. Press **YES** to enter the Special functions menu.
4. Select **Show Id** and press **YES** to make the call.

Not for Commercial Use
Ericsson Mobile Communications AB

During a Call

Your phone has several functions which you might find helpful while a call is in progress.

CHANGING THE EARPIECE VOLUME

During a call you can change the earpiece volume.

To change the earpiece volume during a call

- Press the volume key on the side of the phone up or down.
 - Pressing **UP** increases the volume.
 - Pressing **DOWN** decreases the volume.

MUTING THE MICROPHONE

During a call you may want to talk to someone else in the room without the person on the line hearing the conversation.

To turn the microphone off temporarily during a call

1. Press and hold the **CLR** key. **Mute** is shown in the display.
2. Release the **CLR** key to turn the microphone on again.

Tip! *You can also press and hold the Push-to-talk button to mute the microphone.*

SCRATCH PAD FUNCTION

If you need to write down a phone number during a call, you can use the Scratch pad function.

To use the Scratch pad

- Enter the phone number using the number keys.
When you end the call, the number remains in the display. You can now call the number by pressing **YES** or save it in the Phone Book. See “*Your Personal Phone Book*” on page 33.

Note! *If you press any numeric key while on the phone, the person on the other end of the line hears a tone.*





SENDING TONE SIGNALS

To use telephone banking services or control a telephone answering machine, you need to use codes. These codes are sent as tone signals (also known as DTMF tones or touch tones).

To send tone signals/codes during a call

- Press the appropriate keys (0–9, * and #).

Tip! *You can also save the code together with a number in the Phone Book. See “Your Personal Phone Book” on page 33.*

Note! *If you send tone signals while on the phone, the person on the other end of the line hears the tones.*

CHECKING DURATION/COST OF CALL

During a call, the display shows the duration of the call in minutes and seconds. If you prefer, you can have the call cost displayed, provided your network and your SIM card support this feature. See “*Knowing the Call Time/Call Cost*” on page 78 for more information.

MORE THAN ONE CALL SIMULTANEOUSLY

Your phone is capable of handling more than one call simultaneously. You can put the current call on hold, and then make or answer a second call. You can also set up a conference call with up to five people. See “*Handling More than One Call Simultaneously*” on page 74 on how to use this feature.

Speakerphone

The R250s PRO is equipped with a speakerphone which, when on, increases the earpiece/loudspeaker volume significantly.

The speakerphone is very useful when e.g. you need to speak to someone on the phone and continue using both hands. You may, e.g. receive some instructions over the phone that you need both hands to perform.

The speakerphone is also convenient when you want other people to participate in a conversation. Call the person you want to talk to, switch to speakerphone mode and place the phone on a table e.g. Now, all the people around the table can talk to the person on the other end of the line.

Note! *If you are using a GSM Pro SIM card, the speakerphone mode is not available. Please refer to the information in chapter "GSM Pro" on page 90.*

TURNING ON THE SPEAKERPHONE

To turn on the speakerphone you slide the mode switch on the right side of the phone upwards (see "Overview" on page 4).

Tip! *The phone has different volume settings for phone and speakerphone modes. See "Earpiece Volume" on page 47.*

Switching Between Phone and Speakerphone Mode

You can switch between phone and speakerphone mode at any time: when the phone is in standby; when you receive a call and during a call.

When you receive a call you can switch from phone to speakerphone mode or vice versa to answer the call. The call will then be answered in the selected mode.

To switch between phone and speakerphone mode

- Slide the **MODE SWITCH** upwards to go to speakerphone mode.
- Slide the **MODE SWITCH** downwards to go to phone mode.

When you switch mode the phone sends out a warning tone.

While the phone is in speakerphone mode, do not hold the phone close to your ear as this may cause damage to your hearing. Hold the phone in front of your face around 30-50 cm away and speak into the microphone.



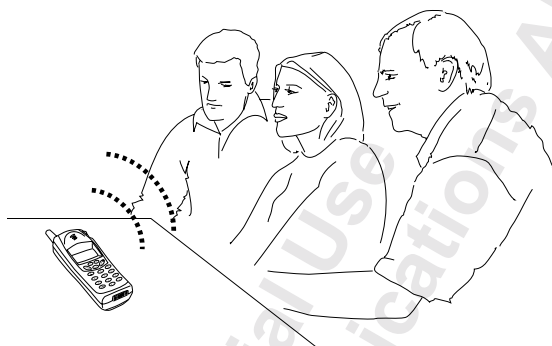

MAKING AND RECEIVING CALLS

Making and receiving calls in speakerphone mode is done in the same way as in phone mode.

To make a call in speakerphone mode

1. Enter the phone number, including the area code, and press **YES**. Do not hold the phone close to your ear during the conversation.
2. Press **NO** to end the call.

To answer a call in speakerphone mode

1. Press **YES** to answer the call.
Do not hold the phone close to your ear during the conversation.
 - If your phone is in phone mode you can also answer the call by sliding the mode switch upwards to go to speakerphone mode.
2. Press **NO** to end the call.

To reject a call

- Press **NO** or double click the volume key (up or down).

Not for Commercial Use
© 2011 Ericsson Mobile Communications AB

FUNCTIONS AND SETTINGS

Using the Menu System	30
Your Personal Phone Book	33
Keeping Track of Your Phone Calls	42
Your Voice Mail Service	44
Personalizing Your Phone	46
Sending and Receiving Text Messages (SMS)	53
Diverting Incoming Calls	62
Security for Your Phone and Subscription	64
Setting Network Preferences	70
Handling More than One Call Simultaneously	74
Knowing the Call Time/Call Cost	78
Using Two Phone Lines	81
Calling Card or Credit Card Calls	83
Sending and Receiving Fax and Data calls	85
Some Useful Tools	86

Using the Menu System

The menu system allows you to control the phone's functions and to customize it to suit your personal preferences. You use the menu system every time you want to change a setting in your phone, such as the ring signal.

Each menu contains a list of options. Some menus have sub-menus with additional options.

MOVING THROUGH THE MENU SYSTEM

The menus are arranged in a continuous loop, which you move (scroll) through with the **LEFT**, **RIGHT**, **YES**, **NO** and **CLR** keys.

Press...	to...
RIGHT	scroll clockwise through menus or functions.
LEFT	scroll anti-clockwise through menus or functions.
YES	select a menu or function, enter a sub-menu.
NO	go back one level in the menu system and/or leave a setting unchanged.
CLR	go back to the standby display.

Tip! *Instead of pressing the **RIGHT** or **LEFT** key repeatedly, you can press and hold it down until you reach the menu or sub-menu you want.*

Note! *If you enter the menu system, but do not press a key within 60 seconds, the phone returns to standby mode.*

To select a menu or make a setting

1. Press the **RIGHT** or **LEFT** key until you find the menu or function you want.
2. Press **YES** to enter the menu or to select the function.
3. Press the **RIGHT** or **LEFT** key to find the sub-menu you want or to select a setting alternative.
4. Press **YES** to enter the sub-menu or to confirm the setting.

DISPLAY TEXT AND SYMBOLS

When you move through the menu system, the display changes. The following hints can help you:

- Capital letters are used to indicate the menu or function selected.



- When \leftarrow and \rightarrow are displayed, there are more options you can scroll through with the **RIGHT** and **LEFT** keys.
- Text in brackets shows the current setting of the function shown in the display.

In this manual, we have chosen to exclude some of the details above in the pictures of the displays. This is to make it easier for you understand the display texts in the margins.

Below is an overview of the main menus. Please note that other menus are available if you subscribe to the two line service and if you have turned on the Data menus.

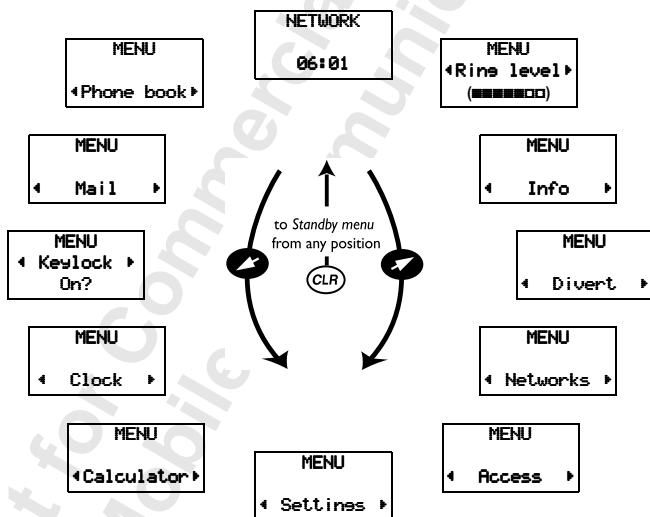

INTERPRETING THE INSTRUCTIONS IN THE MANUAL

To help you understand the instructions in this manual, see the example below of how to interpret the instructions.

Example:

1. Scroll to **Settings**, **YES**, **Key sound**, **YES**.
2. Select the key sound you want and press **YES**.

Interpret This Instruction As Follows:

1. From the standby mode, use the **LEFT** or **RIGHT** keys to scroll to the **Settings** menu.

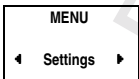

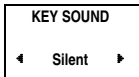
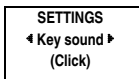
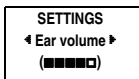

The arrows on either side of the word **Settings** mean that you can scroll to another menu.

2. Press **YES** to select the **Settings** menu.

Now you are in the **Settings** menu. The name of the menu that you have chosen is shown in capital letters at the top of the display.

3. Use the **LEFT** or **RIGHT** keys to scroll to the **Key sound** menu.

The current setting is shown in brackets at the bottom of the display.

4. When you find the **Key sound** menu press **YES** to select it.
5. Use the **LEFT** or **RIGHT** key to find the key sound you want.
6. Press **YES** to select the key sound.
7. Press **CLR** to return to standby.

Your Personal Phone Book

Your phone has a phone book in which you can store names and numbers. The phone book also keeps track of your last dialled numbers and, if you subscribe to the Calling Line Identification service (CLI), the last answered numbers. Convenient if you have to call someone back. Please see “*Keeping Track of Your Phone Calls*” on page 42 for more information.

When you receive a call and the caller’s number and name is stored in the phone book, you see the name in the display.

If you are planning to use your phone abroad, it is a good idea to store all your phone numbers with the international (+) sign.

JIM
(4)
+123456789

PHONE BOOK MEMORIES

You can store your phone numbers in two different memories:

- the card memory on the SIM card.
- the phone memory.

Every phone number that you store includes a position number, shown in brackets. If the number is stored in the phone memory (see below) a (⌘) is shown in front of the position number.

Storing your numbers in the card memory allows you to use the numbers stored on the SIM card even when you change phones, i.e. when you insert your SIM card into another phone.

On the other hand, by storing your numbers in the phone memory, they are always available to you on your phone, even if you change SIM cards.

The memory positions in the card memory are numbered from 1 upwards. The actual number of memory positions available depends on your SIM card.

The phone memory can hold up to 99 phone numbers. The memory positions are labelled ⌘1 – ⌘99.

Note! In the Phone Book menu, press # to enter the ⌘ character. Outside the ‘Phone book’ menu, you must press and hold down # to enter the ⌘ character.

JIM
(⌘4)
+81234567890

If you are using a SIM Pro card, see “GSM Pro” on page 90. Some storing positions on the SIM card may be used by your service administrator. This means that you may not be allowed to edit, store or erase these positions. For more information, please contact your service administrator.

International Numbers

If you intend to use your phone both at home and abroad, you should store all phone numbers as international phone numbers, that is with the ‘+’ sign – which replaces the international dialling prefix for the country you are calling from – followed by the country code, then the area code and the phone number.

- To enter the ‘+’ sign, press and hold **0**.
- Omit the leading zero in the area code.

ENTERING LETTERS

You can only enter letters when you are using the phone book and when you are composing text messages (e.g. SMS), see “Sending and Receiving Text Messages (SMS)” on page 53.

Press the appropriate key, **1–9, 0** or **#**, repeatedly until the character you want appears in the display.

Press...	to get...
1	Space - ? ! , . : " ' () 1 ; < =>
2	A B C Ä Å Æ à Ç 2 Γ
3	D E F è É 3 Δ Φ
4	G H I i 4
5	J K L 5 Λ
6	M N O Ñ Ö Ø ò 6
7	P Q R S ß 7 Π Σ
8	T U V Ü ù 8
9	W X Y Z 9
0	0 + & @ / \$ % £ Θ Ξ Ψ Ω ρ ¥ § ζ ι
#	# *

Example

- To enter an **A**, press **2** once.
- To enter a **B**, press **2** twice.
- To enter lower case letters. Enter the letter, e.g. an ‘A’. Then press *, an ‘a’ appears. Lower case letters will now appear until you press * again.

STORE 19
Name: John Doe

STORE 19
Name: John Doe
Enter no: 0123456

STORE #15
Name: John Doe
Enter no: 0123456



STORE 34
Bankbyphone
012345678p

- To enter the second letter on the numeric keys straight away, e.g. a 'B', press and hold the volume key upwards, then press **2**. To enter the third letter, e.g. a 'C', press and hold the volume key downwards, then press **2**.
- To enter a digit press and hold the desired key.
- To erase letters to the left of the cursor press **CLR**.

STORING A NUMBER TOGETHER WITH A NAME

1. Scroll to **Phone book**, **YES**, **Store**, **YES**.
2. Enter a name to accompany the phone number.
3. Press **YES**.
4. Enter the phone number.
5. You now have four options:
 - Press **YES** to save the number in the card memory, in the first empty position (displayed in the top right-hand corner).
 - To save the number in the card memory, in a position you decide: press the **RIGHT** key, enter the position and then press **YES**.
 - To save the number in the phone memory, in the first empty position: press the **RIGHT** key, press the **#** key twice and then press **YES**.
 - To save the number in the phone memory, in a position you decide: press the **RIGHT** key, press the **#** key once, enter the position and then press **YES**.

Tip! If you enter a number in the scratch pad during a call, you can store it in the Phone Book by selecting **Store** from the **Phone Book** menu while you have the number in the display.

Telephone Banking Services

To use telephone banking services or control a telephone answering machine, you need to use codes. These codes are sent as tone signals (also called DTMF tones or touch tones).

To store a number together with an account number and security code

1. Scroll to **Phone book**, **YES**, **Store**, **YES**.
2. Enter a name to accompany the phone number.
Use the numeric keys as described above.
3. Press **YES**.
4. Enter the phone number.
5. After entering the phone number, press and hold the * key until the pause character **p** appears.
6. Enter the code. If needed, insert another pause, another code and so on.
7. Press **YES** to store.

To make a call with tone signal codes, proceed as described in “*Making and Receiving Calls*” on page 19. When you make the call, the phone dials the number, waits until the call is answered and then sends the code. If you inserted another pause and another code, it pauses again, sends the next code and so on.

STORE 2
Used
Overwrite?

OVERWRITE PROTECTION

If you try to store a phone number in a position which already contains a phone number, the message **Used Overwrite?** appears in the display. You then have two options.

To store the number in the selected position

- Press **YES** to replace the number with the new one.

To store the number in a different position

1. Press **NO**.
2. Enter the new position number and press **YES**.

When a Memory is Full

If you try to store a phone number, e.g. in the phone memory, and the memory you want to store it in is full, the phone suggests a position number in the memory that is not full, in this case the card memory.

When Both Memories are Full

If both memories are full, no position number is suggested. If you still wish to store the phone number, you have to erase an old number by entering a position number that is already occupied.

To erase a phone number from the phone book memory

1. Scroll to **Phone book**, **YES**, **Erase**, **YES**.
2. Enter or scroll to the position number you want to erase.
3. Press **YES** to erase the number.

ERASE 19
◀ John Doe ▶
Erase?



Tip! You can also recall the number you want to erase by using **Name recall** or **Position recall**. When the name appears, press and hold **CLR**. The message **Erase?** appears in the display. Press **YES** to erase the number.

To erase all numbers from the phone memory

1. Scroll to **Phone book**, **YES**, **Erase all from phone**, **YES**.
The message **Erase 30 positions?** appears in the display, where the number indicates the total number of entries stored in the phone memory.
2. To erase all phone numbers from the phone memory, press **YES**.

ERASE ALL
Erase 30
positions?

Note! It is not possible to erase all phone numbers from the card memory.

Note! If you are using a GSM Pro card (see “GSM Pro” on page 90) some storing positions on the SIM card may be used by your service administrator. This means that you may not be allowed to use these positions for storing your own phone book entries. For more information, please contact your service administrator.

USING THE PHONE BOOK

The Push-To-Talk button on the left side of the phone, (see “Overview” on page 4), makes it very easy to call a number that you have stored in your phone book. To call a number, you only need to press the Push-To-Talk button to enter and scroll through your phone book entries.

To call a number in the phone book using the Push-To-Talk button

1. Press **CLR** to go to standby (if you are not already in standby).
2. Press and hold the **PUSH-TO-TALK** button to enter the phone book and scroll through the entries until you find the number you want to call.
3. Press **YES** to make the call.

Calling a Number in the Phone Book Using the Keypad

You can also call a number stored in the phone book by recalling the name stored with it or recalling the memory position that the number is stored in.

To recall a phone number using the name

1. Scroll to **Phone book, YES, Name recall, YES**.
2. Enter the name you want to recall (or the first letters of it) using the numeric keys as described above.

You do not have to enter the entire name; the first few letters will do. The phone matches the letters with existing names in its memory.

3. Press **YES**.

The best match between the letters you entered and the names in the Phone Book is displayed. You can also see the storage position in brackets.

4. If the name displayed is not the one you want, press the **LEFT** or **RIGHT** key until you find the correct name and number.
5. Press **YES** to make the call.

Tip! You can also enter the name directly after pressing **LEFT** from the empty standby display.

If you know the memory position in which you have stored a certain phone number, you can recall the number by using the position.

NAME
RECALL
Name: SUE

SUE
(6)
012345678900



NAME RECALL
Position: 6

SUE
(6)
012345678900



To recall a phone number using the position

1. Scroll to **Phone Book**, **YES**, **Position recall**, **YES**.

2. Enter the position number of the stored phone number.

For a position in the card memory, simply enter the number. For a position in the phone memory, press and hold the **#** key until the 'x' character appears and then enter the number.

3. Press **YES**.

The name and phone number now appear in the display.

If you entered the wrong position number, press the **LEFT** or **RIGHT** key repeatedly until you find the phone number you want.

4. Press **YES** to call the number.

Tip! You can also enter the position directly in the standby display and then press the **#** key to recall the phone number. Do not forget the 'x' before the position if the number is stored in the phone memory (to get the 'x' character, press and hold the **#** key).

The Speed Dialling Facility

You can call the phone numbers that you store in positions 1–9 in the card memory by entering the position number and then pressing **YES**. It is a good idea to save positions 1–9 for important numbers.

Example:

To call Bob, whose number is stored in position 3 in the card memory:

1. Enter the number **3**.

2. Press **YES**.

KEEPING THE PHONE BOOK UP TO DATE

Sometimes people change their names, their phone numbers or even both. To get the best use out of your phone book, you want the names and numbers to be correct. They are easily changed with the **Edit** feature. If someone has changed both name and number, it might be easier to overwrite the old storage position with the new one, instead of changing both name and number separately.

Note! If you are using a **SIM Pro** card you may not be allowed to edit the phone numbers that your service administrator are using.

There are two ways of finding the Phone Book entry you wish to edit. You can use either the storage position or the name.

EDIT
◀ Find pos ▶
Position 6

EDIT 6
BOB
012345678900

EDIT
◀ Find name ▶
Name BOB

COPY ALL
◀ Card→Phone ▶

COPY CARD
From start
Position: _

To edit an entry using the position

1. Scroll to **Phone book**, **YES**, **Edit**, **YES**, **Find pos**.
2. Enter the position number for the entry you wish to edit.

For a position in the card memory, simply enter the number. For a position in the phone memory, press and hold the **#** key until the '⌘' character appears and then enter the number.

3. Press **YES**.

You will now see:

- the name (displayed in the middle row)
- the phone number (displayed in the bottom row)
- the storage position (displayed in the top row)

4. To select the row you wish to edit, press the **RIGHT** key.

You see the cursor to the right of the row you selected.

5. Edit the row by using:

- the **CLR** key to erase
- the numeric keys to enter letters or digits
- the **LEFT** key to move the cursor left (or the **RIGHT** key to move the cursor right when it is positioned in a row)

6. If needed, press the **RIGHT** key to select another row and continue editing.
7. To save the changes, press **YES**.

To edit an entry using the name

1. Scroll to **Phone book**, **YES**, **Edit**, **YES**, **Find name**, **YES**.
2. Enter the name for the entry you wish to edit, using the numeric keys. The more letters you enter, the better the match.
3. To select the entry, press **YES**.
4. You can now continue from step 4 as described above.

COPYING PHONE NUMBERS BETWEEN MEMORIES

If you want to change SIM card or phone, it is a good idea to copy the phone book entries stored on your SIM card to the phone memory or vice versa.

Then you can easily copy the phone book back to the memory of your choice. Also, as you fill up the phone book memories, you might want to move entries from one memory to another.

To copy all numbers from card memory to phone memory

1. Scroll to **Phone book**, **YES**, **Copy all**, **YES**.
2. Select **Card→Phone** and press **YES**.
3. Enter the number of the first position in the card memory you wish to copy to the phone memory and press **YES**.

COPY ALL
◀ Phone→Card ▶

COPY PHONE
From start
Position: 2_

COPY
◀ Card→Phone ▶

BOB
6
Copy to 29

4. Enter the number of the first position in the phone memory you wish to copy to and press **YES**.

The message **Old pos will be erased Start copy?** appears in the display.

5. Press **YES** to start copying.

Note! *If you are using a SIM Pro card the menu “Copy all Card→Phone” may not be available.*

To copy all numbers from the phone memory to the card memory

1. Scroll to **Phone book, YES, Copy all, YES**.
2. Select **Phone→Card** and press **YES**.
3. Enter the number of the first position in the card memory you wish to copy to the phone memory and press **YES**.
4. Enter the number of the first position in the phone memory you wish to copy to and press **YES**.

The message **Old pos will be erased Start copy?** appears in the display.

5. Press **YES** to start copying.

To copy numbers from card memory to phone memory one by one

1. Scroll to **Phone book, YES Copy, YES**.
2. Select **Card→Phone** and press **YES**.
3. Enter the number of the first position in the card memory you wish to copy and press **YES**.
4. Enter the number of the first position in the phone memory you wish to copy to and press **YES**.
5. Press **YES** to start copying.

The starting position in the card memory is displayed and the next empty position in the phone memory is suggested.

6. To continue copying, press one of the following:
 - **YES** to copy.
 - **NO** to go to the next position in the card memory.
 - **CLR** to copy to another position in either the card or phone memory. Enter the number of the position and press **YES**.
 - The **LEFT** and **RIGHT** key to move between positions in the card memory.

To interrupt copying

- Press **CLR** twice.

To copy numbers from phone memory to card memory one by one

1. Scroll to **Phone book**, **YES**, **Copy**, **YES**.
2. Select **Phone** → **card** and press **YES**.

To copy from the phone memory to the card memory use the **YES**, **NO** and **CLR** keys as described in “*To copy numbers from card memory to phone memory one by one*” above.

Not for Commercial Use
Ericsson Mobile Communications AB

Keeping Track of Your Phone Calls

CALLING SOMEONE WHO HAS CALLED YOU

If you subscribe to the Calling Line Identification service, and the caller's network sends the number, the numbers of the last ten answered calls are stored in the phone memory.

To recall one of the last ten answered numbers

1. Scroll to **Phone book, YES, Answered calls, YES**.
2. Select the number you want to call.
3. Press **YES** to make the call.

To clear the answered calls memory

1. Scroll to **Phone book, YES, Answered calls, YES**.

2. Press **CLR**.

The question **Erase all?** appears.

3. Press **YES** to erase all numbers from the answered calls memory.

UNANSWERED CALLS

If you have received calls but have been unable to answer, the number of missed calls is shown in the display in standby mode until you press **CLR**.

Information about the ten last missed calls is saved in the phone memory, which makes it possible for you to see when the calls were received. If your subscription includes the Calling Line Identification service and the caller's network sends the number, you can also find out who called. If you have stored the number together with a name in the phone book the name also appears. See "Your Personal Phone Book" on page 33.

To find out who called and when

1. Scroll to **Mail, YES, Missed calls, YES**.

The last caller's number (if your subscription includes the Calling Line Identification service) is now shown in the display together with the time

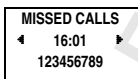
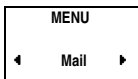
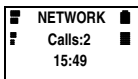
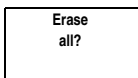
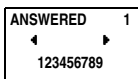

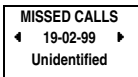

(or date) when the call was received. If no information about the caller's number was received, the display shows one of the following:

- **Unidentified**, which means that no information was available.
 - **Restricted**, which means that the caller wanted to withhold the number.
2. To see your other unanswered calls, press the **LEFT** or **RIGHT** arrow key repeatedly.
 3. Press **NO** to return to the **Missed calls** menu.

Note! *If you check a missed call the same day as you received it, the time of the call is displayed. Otherwise, the time is replaced by the date. You can toggle between date and time by pressing *.*

To call a number from the missed calls list

1. Scroll to **Mail, YES, Missed calls, YES**.
2. Select the number you want to call and press **YES**.
3. Press **NO** to end the call.

To erase a number from the missed calls memory

1. Scroll to **Mail, YES, Missed Calls, YES**.
2. Select the number you want to erase and press **CLR**.
The question **Erase?** appears in the display.
3. Press **YES** to erase the number.

Your Voice Mail Service

Note! *Not all operators have this service. The service also depends on your subscription.*

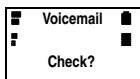

The answering service of your network allows callers to leave a voice message when you cannot answer your calls. When you receive a voice mail, an alert signal sounds, if turned on, and the voice mail icon appears in the display.

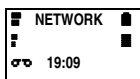

Whenever you have a waiting voice mail waiting for you a  symbol is shown at the bottom of the display.

Further information about the use of the answering service is found in the information supplied by your network operator.

Note! *Some operators may inform you of a waiting voice mail by sending a SMS (see "Sending and Receiving Text Messages (SMS)" on page 53).*

ENABLING THE VOICE MAIL FUNCTION

On most SIM cards the number to the Voice mail service is stored on the SIM card. If the number cannot be retrieved from your SIM card, you need to enter the phone number yourself.

To enter the phone number to the voice mail service

1. Scroll to **Mail, YES, Set VoiceM, YES, New number, YES.**
2. If no number appears, enter the new number.
3. Press **YES** to confirm your new number.

To enable the Voice mail function on your phone

1. Scroll to **Mail, YES, Set VoiceM, YES.**
2. Select **On** and press **YES.**

CALLING YOUR VOICE MAIL

When you receive a voice mail, this is indicated in the display by the message **Voicemail Check?**. You can now check your message by pressing **YES**.

If you press **NO**, you can call the answering service at any time later on to listen to your recorded messages. To do this:



- Scroll to **Mail, YES, Voice mail, YES.**

The phone automatically calls your voice mail. Follow the instructions given to you by your operator's answering service.

Tip! *You can also call your voice mail number by pressing and holding **1** in standby mode.*

To change your voice mail number

1. Scroll to **Mail, YES, Set VoiceM, YES, New number, YES.**
2. Enter the new number and press **YES.**

To change the voice mail alert signal

1. Scroll to **Settings, YES, Mail Alert, YES.**
2. Select the alert signal you want and press **YES.**

To turn the voice mail off

1. Scroll to **Mail, YES, Set VoiceM, YES.**
2. Select **Off** and press **YES.**

Not for Commercial Use
Ericsson Mobile Communications AB

Personalizing Your Phone

The **Settings** menu includes a number of functions which lets you adapt your phone to your own personal preferences. Some of the settings are only affected if you have external equipment (e.g. handsfree equipment) connected to your phone.

DISPLAY LANGUAGE

Most modern SIM cards automatically set the display language to the language of the country where you bought your SIM card. If this is not the case the default language is English.

To change the display language

1. Scroll to **Settings, YES, Language, YES.**

The currently selected language is shown in brackets.

2. Select the language you want and press **YES.**

Note! *If by accident you end up with a language you do not understand, you can return to English by pressing **LEFT 0000 RIGHT** at any time.*

ALERT BUTTON

The R250s PRO is equipped with an **Alert button** located on the top of the phone, next to the antenna (see “*Overview*” on page 4). By pressing and holding the alert button you can easily set up a call to a pre-defined alert number, without having to dial the number in the ordinary way.

When you buy your phone, the alert number (when using the Alert button) is set to the international emergency number 112. This number can be changed, if you prefer to use another alert number.

Note! *If you change the pre-set alert number (112), you must insert a SIM card and enter the PIN code (if the card is locked). Otherwise the pre-set alert number (112) will be dialled and not the number you have specified.*

You must turn on the alert function before you can use the alert button. When you buy your phone the alert button is activated.

SETTINGS

◀ Language ▶
(Auto)

SETTINGS

◀ Alert key ▶

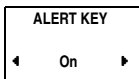

To turn the Alert button on or off

1. Scroll to **Settings**, **YES**, **Alert key**, **YES**.
2. Select **On** or **Off** and press **YES**.

To change the alert number

1. Scroll to **Phone book**, **YES**, **Alert number**, **YES**.
2. Edit the number in the same way that you edit other phone book entries.
You can also associate a name with the alert number. See "Your Personal Phone Book" on page 33
3. Press **YES** to confirm your new alert number.

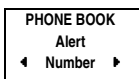

Note! If fixed dialling is activated, the alert number must be included in this list. If it is not included, you cannot use the alert button to make an alert call. However, if the alert number is the international emergency number 112 you do not have to include it in the fixed dialling list. For more information about fixed dialling, see "Fixed Dialling and Fixed Incoming Calls" on page 68.

EARPIECE VOLUME

There are two separate volume settings for your phone, depending on which mode, Phone or Speakerphone, you have currently selected. The mode currently selected is displayed in the middle row when you enter the **Ear volume** menu.

You can have independent volume settings when you use the phone together with different handsfree equipment. This means that if you set the earpiece volume when the phone is connected to handsfree equipment, the volume setting when the phone is handheld is not affected and vice versa.

Note! If you are using a SIM Pro card there will be a volume setting for the Push-to-talk mode instead of the speakerphone mode. See "Earpiece volume" on page 91.

To set the earpiece volume

1. Scroll to **Settings**, **YES**, **Ear volume**, **YES**.
The current mode, **Phone** or **Speakerphone**, is displayed in the middle row.
2. Use the **LEFT** key to decrease the volume.
Use the **RIGHT** key to increase the volume.
3. Press **YES** to confirm your volume setting.

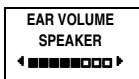

Tip! During a call you can use the volume keys at the side of the phone to adjust the volume.

Note! When you switch the phone to Speakerphone mode (or Push-to-talk mode) the loudspeaker volume increases significantly. Do not hold the phone



close to your ear during a conversation as it may cause damage to your hearing. For more information, see “Speakerphone” on page 26.

RING SIGNAL VOLUME

You can set the ring signal level in seven steps. The first step means that two clicks are heard when you receive a call. The last step means that the phone rings with an increasing ring signal. You can also turn the ring signal off. The Ring level setting allows you to specify the level:

- when the phone is handheld.
- when the phone is connected to handsfree equipment.

To set the ring signal level

1. Scroll to **Ring level, YES, Buzzer, YES**.
2. Use the **LEFT** and **RIGHT** key to set the ring signal level.
 - Pressing **RIGHT** increases the volume.
 - Pressing **LEFT** decreases the volume.

The phone rings once with the actual setting as you increase the volume, except for the **Off** and **Step** settings.

3. Press **YES** to save the setting.

Tip! Use the side keys to change the ring level silently.

VIBRATING CALL ALERT

If you turn the Vibrating call alert on the phone vibrates when you receive a call or a text message. This is useful when you e.g. are working in a noisy environment and cannot hear the phone ringing.

To turn the vibrating call alert on or off

1. Scroll to **Ring level, YES, Vibrator, YES**.
2. Select **On** or **Off** and press **YES**.

Note! You can choose to have both the buzzer and the vibrating call alert on at the same time.

RING SIGNAL TYPE

You can choose a ring type from a list of different sounds and melodies. You can also compose your own melody by entering notes with the keypad (see “Composing your own melody” below).

To choose one of the ring signal types

1. Scroll to **Settings, YES, Ring type, YES**.
The current ring signal type is displayed.
2. Select the ring signal type you want and press **YES**.

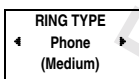

Note! If the Data menus are set to on (See “Sending and Receiving Fax and Data calls” on page 85), you can set the ring signal type for speech (the display shows ‘Phone’ in the middle row), fax and data calls respectively. If you have the Two Line service, see “Using Two Phone Lines” on page 81), you can also set different ring types for the two lines.

COMPOSING YOUR OWN RING SIGNAL

You can compose a melody of your own to use as your ring signal.

To compose your own ring signal

1. Scroll to **Settings**, **YES**, **Edit Melody**, **YES**.
2. Use the numeric keys to enter notes.
3. Press **YES** to listen to the melody.
The question **Ready?** appears in the display.
4. If you want to save the melody press **YES** to save it. If not, press **NO** and continue editing.

MESSAGE SIGNAL

You can choose whether to hear clicks, the mixed ring signal or nothing (silent) when you receive a text or voice message, i.e. a SMS.

To set the message signal

1. Scroll to **Settings**, **YES**, **Mail alert**, **YES**.
2. Select the sound you want to hear when you receive a message.
3. Press **YES** to confirm your selection.

MINUTE MINDER

When the minute minder is activated, you hear a beep once every minute while you are on the phone.

To turn on/off the minute minder

1. Scroll to **Settings**, **YES**, **Min minder**, **YES**.
2. Select **On** or **Off** and press **YES**.

KEY SOUND

You can choose whether to hear clicks, tones or nothing (silent) when you press the keys.

To set a key sound

1. Scroll to **Settings**, **YES**, **Key sound**, **YES**.
2. Select the key sound you want and press **YES**.

Note! The only sound available for the volume keys is the click sound.

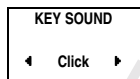
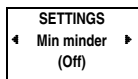
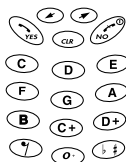

DISPLAY LIGHT

The display light can be set to automatic, off or on. In automatic mode, the display light is turned off automatically 20 seconds after the last key is pressed. It is turned on again when a key is pressed or when a call or message is received.

To set the display light

1. Scroll to **Settings**, **YES**, **Light**, **YES**.
2. Select the display light setting you want and press **YES**.

Note! You can have one setting when the phone is used as a handheld unit and another when the phone is used with a handsfree kit, powered from an external source. E.g. if you place the phone in a vehicle handsfree holder, you can set the display light so that it is always on.

GREETING TEXT

When you turn on your phone, a greeting text appears in the display. Instead of the default greeting, you can have your phone display a welcome greeting that you write yourself. However, some operators may not allow the greeting text to be changed.

To enter your own greeting

1. Scroll to **Settings**, **YES**, **Greeting**, **YES**, **New text**, **YES**.
2. Enter your new greeting, using the numeric keys. For information on how to enter letters, see "Entering Letters" on page 34.
3. Press **YES** to confirm your new greeting text.

To turn the Greeting text on/off

1. Scroll to **Settings**, **YES**, **Greeting**, **YES**.
2. Select **On** or **Off** and press **YES**.

PHONE NUMBER DISPLAY

When you turn on your phone, your phone number will be displayed, provided it can be retrieved from your SIM card. If not, you can enter it yourself.

To enter your phone number

1. Scroll to **Settings**, **YES**, **Phone no**, **YES**.
2. Enter your phone number.
3. Press **YES** to confirm your choice.

Note! If your SIM card allows it, you can also enter your fax and/or data number.

SETTINGS
◀ Light ▶
(Auto)

GREETING
◀ New text ▶
(Welcome)

NUMBER
◀ Phone no ▶
()

TIME AND DATE

The **Clock** menu lets you set the time and date. It also lets you turn on the alarm function (see “*Alarm*” on page 86). The time is shown continuously at the bottom of the display when the phone is in standby mode.

When you buy your phone, the time is set to the 24-hour format. If you wish you can change it to the 12-hour format.

To change the time format

1. Scroll to **Clock, YES, Clock mode, YES.**
2. Select the clock mode you want, **24 hours** or **AM/PM.**
3. Press **YES.**

To set the clock

1. Scroll to **Clock, YES, Set Clock, YES.**
2. Enter the time in hours and minutes.
3. Press **YES.**

Note! If you select the 12-hour format in the ‘Clock mode’ function, you can alternate between *am* and *pm* by pressing #.

The Date

It is possible to have the date displayed in the middle row of the display when the phone is in standby mode.

To set the date

1. Scroll to **Clock, YES, Set date, YES.**
2. Enter the year (two digits) and press **YES.**
3. Enter the month and day in the same way.
4. Press **YES.**

To set the date format

1. Scroll to **Clock, YES, Date mode, YES.**
2. Select the date format you want, or select **Off** if you do not want the date to be displayed.
3. Press **YES.**

MASTER RESET

It is possible to reset all menu settings to the way they were when you bought your phone. To reset all settings you must enter the Phone lock code. The default code when you buy your phone is **0000**. For more information, see “*Security for Your Phone and Subscription*” on page 64.

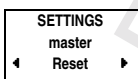
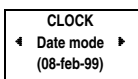
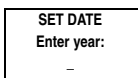
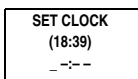
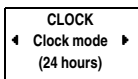

Enter code
to reset

To reset all settings

1. Scroll to **Settings**, **YES**, **Master reset**, **YES**.
2. Enter the phone lock code. (The default code is 0000.)
3. Press **YES** to reset all settings.

Not for Commercial Use
Ericsson Mobile Communications AB

Sending and Receiving Text Messages (SMS)

The Short Message Service (SMS) allows you to send and receive text messages consisting of up to 160 characters. If your phone is turned off when a message is sent to you, an envelope icon lets you know you have a message when you turn your phone back on.

To be able to reply to received messages and send your own messages, the number to your **network service centre** must be set. If your SIM card does not contain the phone number to your network service centre, you must specify the number yourself. See “*Enable the Phone to Send SMS*” on page 54.

Note! *The Short Message Service may not be available in all networks. Some network operators may only allow SMS to be sent within their own network.*

THE TWO MEMORIES

The phone has two memories for storing messages, the phone memory and the card memory.

The Phone Memory

If you do not want to read an incoming message at once, it is automatically stored in the phone memory. This allows you to read it later on.

If there are any unread messages in the messages memory, a letter icon (✉) appears in the bottom left of the display.

The phone memory can hold up to 10 messages. When all memory positions are full, the oldest read message is overwritten when a new message is received. If the phone memory becomes full of unread messages, new messages are automatically stored in the SIM card memory. If the SIM card memory becomes full, the letter icon (✉) starts blinking.

Messages remain in the phone memory until you erase them (see “*Erasing a Message*” on page 57), until you insert a different SIM card, or until the telephone needs the memory space to store new messages.

The SIM Card Memory

If you receive an important message and want to make sure it is not erased from the phone memory, you can store it in a memory on your SIM card. This means that you can retrieve the message regardless of which phone you use. Messages that are saved in the SIM card memory remain there until you erase them. If the SIM card memory becomes full, the letter icon (✉) starts blinking.

ENABLE THE PHONE TO SEND SMS

If the phone number to your network service centre cannot be retrieved from your SIM card, you must specify the number yourself. Otherwise you cannot reply to received messages or send your own messages.

To set the number to your Network service centre

1. Scroll to **Mail, YES, Send message, YES, Options, YES.**
2. Select **Serv cent** and press **YES.**
3. If there is no number in the display enter the number of the service centre, including the international (+) sign and press **YES.**
4. To return to standby mode, press **CLR.**

Your phone is now ready to send and receive text messages.

Note! Some network operators may only allow SMS to be sent within their own network.

COMPOSING A TEXT MESSAGE

In order to compose your message, you have to know how to enter characters using the numeric keys.

Press...	to get...
1	Space - ? ! , . : " ' () 1 ; < =>
2	A B C Ä Å Æ à Ç 2 Γ
3	D E F è É 3 Δ Φ
4	G H I i 4
5	J K L 5 Λ
6	M N O Ñ Ö Ø ò 6
7	P Q R S ß 7 Π Σ
8	T U V Ü ù 8
9	W X Y Z 9
0	0 + & @ / \$ % £ Θ Ë Ψ Ω ρ ¥ § ζ i
#	# *

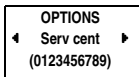

Press the appropriate key, **1–9, 0** or **#**, repeatedly until the desired character appears in the display.

Example:

- To enter an **A**, press **2** once.
- To enter a **B**, press **2** twice.
- To enter lower case letters. enter the letter, e.g. an '**A**'. Then press *****, an '**a**' appears. Lower case letters now appear until you press ***** again.
- To enter the second letter on the numeric keys straight away, e.g. a '**B**', press and hold the volume key upwards, then press **2**. To enter the third letter, e.g. a '**C**', press and hold the volume key downwards, then press **2**
- To enter a digit press and hold the desired key.
- To scroll through the text, use the **LEFT** and **RIGHT** keys.
- To erase letters to the left of the cursor press **CLR**.

To check the first characters you have entered:

- Press the **LEFT** key until you reach the characters you want to view.

Note! *If there is a pause of more than 120 seconds between entering characters, the phone returns to the standby menu.*

SENDING A TEXT MESSAGE

1. Scroll to **Mail, YES, Send message, YES, New, YES**.

An empty display appears.

2. Enter your message. See "*Composing a Text Message*" above.

3. When you have completed your message, press **YES**.

The message **Request reply?** appears in the display

4. If you want the recipient to reply to the message, press **YES**. If not, press **NO**.

5. Enter the recipient's phone number or recall it from the phone book.

To access the Phone Book menu press **LEFT**.

6. You now have two options:

- If you want to send the message now, press **YES**.
- If you want to store the message for later use, press **NO**.

The message is now stored in the messages memory.

If you decide to send the message later, you can find it in the **Send message** menu. The message is labelled **To Send**. For more information on how to send a stored message see "*Frequently Used Messages*" on page 59.

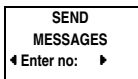
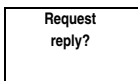
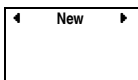

Note! The same procedure is used with all types of messages, for example e-mail, fax etc. Check with your network operator which message types you can use.

CUSTOMIZING YOUR TEXT MESSAGES

If your message cannot be delivered because the recipient has turned off the phone, your Service Centre can save your message and send it again later. If your service centre has not been able to reach the recipient within a specified time the message will be deleted.

To set the validity period of a message

1. Scroll to **Mail, YES, Send message, YES, Options, YES.**
2. Select **Valid per** and press **YES.**
3. Select the duration period you want and press **YES.**

Changing Message Types

The phone is prepared for sending other types of messages. Your network operator's Service Centre may offer the facility of converting a text message into a format, fax, voice, e-mail etc. that suits the equipment that is going to receive the message.

Please contact your operator for further information about the formats you can use.

To set the message type

1. Scroll to **Mail, YES, Send message, YES, Options, YES.**
2. Select **Msg type** and press **YES.**
3. Select the message type you want and press **YES.**

Note! Standard means an ordinary text message (SMS) to other phones. Standard is the default message type.

RECEIVING AND READING A MESSAGE

When you receive a message, you hear a sound, the indicator light on the top of the phone rapidly flashes green and the message **NewMessage Read now?**, appears in the display.

To read the message now

1. Press **YES.**

The display shows who the message is from and when it was received. **New** stands for a new unread message.

If the message is older than 24 hours, the time is replaced with the date the

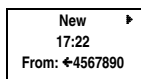
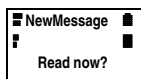
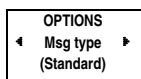
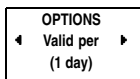

message arrived. However, you can toggle between the date and time by pressing the * key.

2. Press **YES** to read the first line of the message.

Scroll through the message using the **LEFT** and **RIGHT** keys. **RIGHT** takes you forwards, and **LEFT** takes you backwards through the message. To move three lines forward, press **3**. To move three lines backwards, press **1**. To return to the beginning of the message, press and hold **LEFT**.

3. The message **Reply?** appears after the last line of the message. If the caller wants you to reply, the displayed message says **Reply Requested Reply?** provided your network supports this feature.

To read the message later

- Press **NO** when the message **NewMessage Read now?** appears in the display. The message is stored in the phone memory and a letter icon (E) appears on the left at the bottom of the display. See “Reading Stored Messages” on page 58.

REPLYING TO A MESSAGE

After reading a message you are asked if you want to reply.

To reply to a message

1. Press **YES** when you see the **Reply?** prompt at the end of the message. Your display now looks like the picture in the margin.
2. To enter your message, press **YES** and proceed as described in “Sending a Text Message” on page 55.

If you do not want to reply:

- Press **NO**.

Note! *If the sender of the message wants you to reply, the message **Reply Requested Reply?**, appears instead of **Reply?**.*

ERASING A MESSAGE

After reading a message you are asked if you want to reply.

To erase the message

1. Press **NO** when you see the **Reply?** prompt. The message **Erase?** appears in the display.
2. Press **YES** to erase the message. The next message automatically appears in the message list.

Note! *You can also press **CLR** anywhere within the message to erase it. When **Erase?** appears, press **YES**.*

Goodbye!

◀ Reply?

◀ New ▶

Goodbye!

◀ Erase?

STORING A MESSAGE

All incoming messages are stored temporarily in the phone memory until the memory space is needed for other purposes, such as storing new messages. Even so, sometimes you may receive an important message that you want to store more safely. This is better done in the SIM card memory.

To store a message in the SIM card memory

1. Scroll to the end of the message.
2. When the message **Reply?** appears press **NO**.
The message **Erase?** appears.
3. Press **NO** again.
The message **Store?** appears.
4. Press **YES** to store the message on the SIM card.
The message is automatically moved from the phone memory to the SIM card memory.
The display now shows the position of the message. For example, if it is the third of 10 messages that the phone can store.

Note! *If the card memory is full, the text **Not stored Mem full** appears. In this case you have to erase one or more messages before you can store any new messages in the SIM card memory.*

Tip! *You can also store messages you have composed yourself on the SIM card. See “Frequently Used Messages” on page 59.*

READING STORED MESSAGES

1. Scroll to Mail, **YES**, Read messages, **YES**.
2. Select the message you are looking for.
 - **New** stands for a new unread message.
 - **Old** stands for a read message.
 - **Sent** stands for a sent message.
 - **To Send** stands message you have written but not sent.
3. Press **YES** and read the message as described in “Receiving and Reading a Message” on page 56.

Note! *If there is a * in front of the message, this means that it is stored on the SIM card.*

CALLING A PHONE NUMBER FOUND IN A MESSAGE

- Press **YES** when the number appears in the display.
After the number has been called, the message is considered read and it remains in the Messages memory.

Goodbye!

Store?

Stored
on card
3(10)



FREQUENTLY USED MESSAGES

If you have one or more messages you use often, you can store them on the SIM card, to be re-used whenever you want.

Storing Frequently Used Messages

To make sure your standard messages are not erased when the phone memory becomes full, you should store them in the SIM card memory.

To store a frequently used message on the SIM card

1. Scroll to **Mail, YES, Read messages, YES.**

The messages stored in your Messages memory appear.

2. Select the message you want to store in the SIM card memory.
3. Press **YES**. The message **Erase?** appears in the display.
4. Press **NO**. The message **Store?** appears in the display.
5. Press **YES**.

The message is now moved from the phone memory to the SIM card memory.

To send a stored message

1. Scroll to **Mail, YES, Send message, YES.**

The message **New** appears in the display.

2. Scroll with the **LEFT** and **RIGHT** keys until you find the message you want to send.
3. Press **YES**. Now you can edit your message, if you wish.
4. When the message is ready to be sent, press **YES**.

The message **Request reply?** appears.

5. If you want the recipient to reply to the message, press **YES**. If not, press **NO**.
6. Enter the recipient's phone number or recall it from the phone book. To access the **Phone book** menu, press **LEFT**.
7. Press **YES** to send the message.

AREA INFORMATION

The ordinary Short Message Service is a personal service that carries your private messages. Area Information (AI) is a text message which is broadcast to all subscribers in a certain network cell at the same time. The information may be a local road report or a local taxi phone number.

Before you can receive any area information messages, you have to turn on the Area information.

SEND
MESSAGES
◀ Enter no: ▶

To turn area information on/off.

1. Scroll to **Mail, YES, Area info, YES**.
2. Select **On** or **Off** and press **YES**.

You can now receive Area information messages, provided your network operator supports this function.

Area Information Message Types

Each type of Area Information message is identified by a three-digit code. At present, the following message types exist:

Code:	AI Message Type:
000	Index
010	Newsflashes
020	Hospitals
022	Doctors
024	Pharmacies
030	Long-distance road reports
032	Local road reports
034	Taxis
040	Weather
050	District (base station identity)
052	Network information
054	Operator services
056	Directory enquiries (national)
057	Directory enquiries (international)
058	Customer care (national)
059	Customer care (international)

Note! *These codes are operator dependent. For information about the AI services you can use, please refer to the information supplied by your network operator.*

Area Information Message List

You can decide which types of area information messages you wish to receive. The phone's "Area Info" list can hold up to 20 codes.

To insert an Area information code

1. Scroll to **Mail, YES, Area info, YES**.
2. Select **Edit list** and press **YES**.

The digits to the left indicate the position in the list. You can scroll forwards and backwards through the list with the **LEFT** and **RIGHT** keys.

3. To insert a code, scroll to the first empty location, using the **LEFT** or **RIGHT** key and press **YES**.
4. Enter the new code. (You only need to enter 40 for 040, since the phone adds the leading zero automatically).
5. Press **YES**.

To erase or replace a code

1. Scroll to **Mail, YES, Area info, YES, Edit list, YES**.
2. Select the code you wish to erase or replace and press **YES**.
The message **Erase?** appears.
3. If you want to erase this code, press **YES**.
4. If you want to replace the code, press the **RIGHT** key once, followed by **YES**.
5. Enter the new code and press **YES**.

Receiving Area Information

When you receive an Area information message, the message is stored in the phone memory, until you have read it or until you receive a new message.

Provided **Area info** is on, you can read the messages with the Area messages function in the **Mail** menu.

To read an area message

1. Scroll to **Mail, YES, Area messages, YES**.
2. Scroll from one message to another by using the **LEFT** and **RIGHT** keys.
3. Press **YES** to select a message.

Diverting Incoming Calls

If you want to make certain that your incoming calls are taken care of when you are unable to answer them, you can use the Call Divert service to divert them to another phone number.

The Call Divert service lets you:

- divert calls if you are already on the phone – **when busy**.
- divert calls that you do not answer within a specified time limit (operator dependent) – **no reply**.
- divert calls if the phone is turned off or if you are unreachable – **unreachable**.
- divert all incoming calls – **all calls**.

The divert option **All calls** means that all incoming calls are diverted to a number specified by you. If you choose to divert all calls, an arrow ⇄ is shown in the display.

Note! *If you chose the **All calls** divert, all other diverts are automatically cancelled. They are, however, activated again when you cancel the “All calls” divert.*

ACTIVATING CALL DIVERTS

1. Scroll to **Divert, YES**.
2. Select the divert you want (**All calls, On busy, No reply** and **Unreachabl**).
3. Select **Activate**, press **YES**.
4. Enter the phone number, including the area code, to which you want your calls to be diverted and then press **YES**.

Note! *If you used the divert option earlier and then cancelled it, an earlier, recently used number to which the calls were diverted will be suggested. Press and hold **CLR** if you want to erase this number and enter a new one.*

There may be a short delay before the network responds. In the meantime, the message **Please wait** is displayed. This is followed by the message **On busy, All calls, No reply** or **Unreachable – Divert ON**, depending on which divert option you choose. The divert number is also displayed.

The display informs you of a call divert each time you turn the phone on.

◀ DIVERT
All Calls ▶
(Off)

Diverting When the Data Menus Are On

If you have turned the **Data menus** on, you can set call diverts for your phone, fax and data numbers respectively or for all three together. To divert, proceed as described above.

For the fax and data numbers, there are only two divert alternatives:

- all calls
- unanswered

CHECKING THE DIVERT STATUS

1. Scroll to **Divert, YES**.
2. Select the divert you want to check and press **YES**.
3. Select **Get status** and press **YES**.

The message **Please wait** appears, followed by either the phone number and **Divert ON** if the call divert is on, or **Divert OFF** if it is not on.

To check the status of all call diverts

1. Scroll to **Divert, YES**.
2. Select **Check all** and press **YES**.

The message **Please wait** appears, followed by information about all call diverts, i.e. whether they are on or not.

CANCELLING CALL DIVERTS

To cancel a certain call diverts

1. Scroll to **Divert, YES**.
2. Select the divert you want to cancel and press **YES**.
3. Select **Cancel** and press **YES**.

The message **Please wait** appears followed by a message which informs you that the call divert has been cancelled.

To cancel all call diverts

1. Scroll to **Divert, YES**.
2. Select **Cancel all** and press **YES**.

The message **Please wait** appears, followed by a message which informs you that all call diverts have been cancelled.

ALL CALLS

◀ Get status ▶

ALL CALLS

◀ Cancel ▶

Security for Your Phone and Subscription

There are several ways to protect your phone and subscription from unauthorized use. Anything from a simple keypad lock to full phone number control.

KEYPAD LOCK

The Keypad Lock feature helps you to avoid accidental dialling, which can happen if you keep your phone in your pocket or attached to your belt. You can choose between manual and automatic keylock.

An icon in the shape of a key (🔑) in the display informs you that the keypad is locked.

Note! Calls to the international emergency number 112 can be made when the keypad is locked. If the phone alarm rings, you can turn it off by pressing any key.

The keypad remains locked until you:

- answer an incoming call.
- replace the battery.
- unlock the keypad.
- press the Push-To-Talk button (to enter the phone book menu)

To lock the keypad manually

- Scroll to **Keylock** and press **YES**.

To unlock the keypad

- Press **LEFT** followed by **YES**.

The keypad is unlocked.

The Automatic Keypad Lock

Automatic keypad lock means that if no keys are pressed in 25 seconds, the keypad is locked.

To set the automatic keypad lock

1. Scroll to **Settings**, **YES**, **Keylock**, **YES**.
2. Select **Auto** and press **YES**.

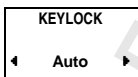
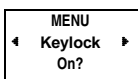

To unlock the keypad

- Press **LEFT** followed by **YES**.
The keypad is unlocked.

Note! The Keypad lock is always disabled if the phone is connected to vehicle handsfree equipment.

THE SIM CARD LOCK

Most modern SIM cards are protected with a **PIN** (Personal Identity Number) at the time of purchase. If the SIM card lock is activated, you have to enter the PIN every time you turn on your phone.

The SIM card lock only protects your subscription and not your phone itself from unauthorized use. If you change SIM card, the phone still works with the new SIM card.

If Your SIM Card is Blocked

If you enter your PIN incorrectly three times in a row, the SIM card is blocked. This is indicated by the message **PIN Blocked Unblock?** If this happens you need to unlock it to access your subscription.

Unblocking Your SIM Card

1. Press **YES**.
2. Enter your PUK (or PUK2 if the PIN2 is blocked) which you will find in the information from your network operator.
3. Press **YES**.

Note! If your PIN starts with the same digits as the international emergency number 112, they appear in the display when you enter your PIN.

Changing your PIN Code

1. Scroll to **Access, YES, Change PIN code, YES**.
2. Enter your old PIN (current) PIN code and press **YES**.
3. Enter your New PIN and press **YES**.
4. At the prompt **Repeat new PIN**, enter your new PIN a second time and press **YES**.

The message **New PIN** confirms that the PIN has been changed.

Note! If the message **Matching error** appears, this means you entered the new PIN incorrectly. If the message **Wrong PIN** appears, followed by **Enter Old PIN**, you entered your old PIN incorrectly.

Enter
old PIN

Changing Your PIN2 Code

Depending on the network you use, some services require that you enter a second PIN, the PIN2.

1. Scroll to **Access, YES, Change PIN2, YES**.
2. Follow the same procedure as described in “*Changing your PIN Code*” above.

Turning On the SIM Card Lock

1. Scroll to **Access, YES, Lock Card, YES**.
2. Enter your PIN code and press **YES**.
The message **Locked** confirms that the card lock is now on.

Cancelling the SIM Card Lock

1. Scroll to **Access, YES, Unlock Card, YES**.
2. Enter your PIN code and press **YES**.
The message **Unlocked** confirms that the card lock is now off.

Note! *This function only applies if your SIM card allows you to turn off the card lock.*

PHONE LOCK

The phone lock protects the phone against unauthorized use if it is stolen and the SIM card exchanged. The Phone lock is not on when you buy the phone. The default security code is **0000**. You can change this code to any three- to eight-digit code of your own choice.

The phone lock has two levels: **Full lock** and **Autolock**:

Full Lock

If the Full Lock is on, you briefly see the message **Phone locked** each time you turn on the phone. The message is followed by the prompt **Enter lock code**. You then have to enter a security code and press **YES** to be able to use your phone.

Autolock

If the Autolock is on, the message **Phone locked** and the prompt **Enter lock code** do not appear until a different SIM card is inserted in the phone. After the security code has been entered correctly, the phone can be used with a new SIM card. You are not asked to enter the security code until the original SIM card or a different SIM card is inserted.

To change the security code

1. Scroll to **Access, YES, Phone lock Change code, YES**.
2. Enter your old code and press **YES**.

ACCESS
◀ Phone lock ▶
Change code

3. Enter your new code and press **YES**.
The message **Repeat new code** appears in the display.

4. Re-enter your new code and press **YES**.
The message **New Code** confirms that the code has been changed.

To lock/unlock the phone

1. Scroll to **Access, YES, Phone lock, YES**.
2. Select the setting you want (**Full lock, Autolock or Unlocked**) and press **YES**.
3. Enter the security code and press **YES**.
Phone Lock is displayed together with the new setting.

CALL BARRING

The Call Barring service of the cellular network allows you to bar different types of outgoing and incoming calls. This means that you can restrict the use of the phone.

Note! *This service may not be available on all networks or may require a separate subscription.*

The following calls can be barred:

- all outgoing calls,
- all outgoing international calls,
- all outgoing international calls except to your home country,
- all incoming calls,
- all incoming calls when you are abroad (when roaming).

To ensure that a call bar is not changed by someone else, you need a password, which comes with your subscription, in order to activate or cancel a call bar.

Changing the Call Barring Status

1. Scroll to **Access, YES, Barring, YES**.
2. Select the **Barring** option you want and press **YES**.
3. You now have three options:

- **Activate**, which turn a call bar on
- **Get status**, which lets you check the status of a call bar
- **Cancel**, which cancels the call bar

4. Confirm your selection by pressing **YES**.
5. Enter your password and press **YES**.

There may be a short delay before the network responds. In the meantime the message **Please wait** is displayed. This is followed by a message which informs you whether the call bar is on or not.

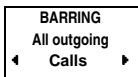

BARRING

◀ Cancel all ▶

Note! If you divert incoming calls, see “Diverting Incoming Calls” on page 62, you cannot activate some barring options. Likewise, if you bar calls, you cannot activate some call divert options.

Cancelling All Call Bars

1. Scroll to **Access, YES, Barring, YES, Cancel all, YES.**
2. Enter your password and press **YES.**

The message **Please wait** appears, followed by a message confirming that all call bars have been cancelled.

Changing the Barring Password

The password for the Barring service comes with your subscription. You can easily change the password as often as you like.

1. Scroll to **Access, YES, Barring, YES, Change password, YES.**
2. Enter the old (current) password and press **YES.**
3. Enter the new password and press **YES.**
4. Enter the new password a second time and press **YES.**

The message **Please wait** appears, followed by a message confirming that the password has been changed.

FIXED DIALLING AND FIXED INCOMING CALLS

Fixed Dialling and fixed incoming calls is a way of restricting outgoing and incoming calls.

Note! Fixed dialling and fixed incoming calls require a SIM card that supports the storing of fixed numbers. The fixed numbers are protected by the PIN2.

The fixed dialling numbers and fixed incoming calls numbers are stored in a list of fixed numbers on the SIM card. The fixed dialling numbers and the fixed incoming calls numbers must be the same. You can however, turn each function on or off independently.

- The Fixed Dialling and Fixed incoming calls functions allow calls to be made and received only to and from fixed numbers stored on the SIM card. If you try to call other numbers, the message **Number not permitted** appears in the display. If someone, who is not included in the Fixed incoming numbers list, tries to call you, he or she will be rejected.
- It is possible to store partial numbers, e.g. an area code, or an area code followed by the first digits common to several numbers. Storing 0123456 allows calls to be made to and received from numbers from 012345600 to 012345699.

- Numbers beginning with the international (+) sign and country code can also be stored, allowing you to make and receive calls from abroad.
- Numbers including **question marks** can be stored. For example storing 01234567?0 allows calls to be made to and received from numbers ending with a zero from 0123456700 to 0123456790. To enter a question mark press and hold the **#** key.
- The maximum fixed numbers that can be stored depends on your SIM card.

Note! *The Fixed Dialling function does not prohibit calls to the international emergency number 112 and the Service Centre of your network operator. Network services such as Call Divert and Call Barring cannot be used.*

To turn fixed dialling on or off

1. Scroll to **Access, YES, Fixed dial, YES**.
2. Enter your PIN2 and press **YES**.
3. Select **On** or **Off** and press **YES**.

To activate or cancel fixed incoming calls

1. Scroll to **Access, YES, Fixed inco, YES**.
2. Enter your PIN2 and press **YES**.
3. Select **On** or **Off** and press **YES**.

To store fixed numbers

1. Scroll to **Phone book, YES, Fixed numbers, YES, Store, YES**.
2. Enter your PIN2 and press **YES**.
3. Enter the name (optional) and a fixed number(s) in the same way as when storing an ordinary phone number.

Note! *To be able to store fixed numbers, you need to activate the fixed dialling function (see above).*

To edit a stored fixed number

1. Scroll to **Phone book, YES, Fixed numbers, YES**.
2. Select **Edit** and press **YES**.

After you have entered the PIN2, you can change the position number, the name or the fixed number in the same way as with an ordinary phone number.

3. Press **YES** when you have finished editing.

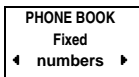
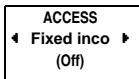
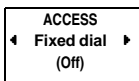

Setting Network Preferences

The **Networks** menu includes a number of functions which you can use to determine how the phone searches for a network. You may also select a network yourself from those within range.

SEARCHING FOR NETWORKS

When you turn on the phone, it searches for the last accessed network. If this is not within range, you may use another network, provided your home network has an agreement that allows you to do so. This is called roaming.

The order of preference in which the phone selects a network is determined by a list of preferred networks on your SIM card. The Networks menu includes a number of functions that let you determine how the phone searches for a network. You may also select a network yourself from those within range.

SEARCH MODES

The phone has two search modes: automatic and manual.

Automatic Search Mode

The automatic search mode means that your phone first searches for the last accessed network. If this is not available, the phone automatically searches for another available network within range.

The Automatic search mode is normally the default setting when you buy your phone.

To turn on automatic search mode

1. Scroll to **Networks**, **YES**, **Searchmode**, **YES**.

If **Auto** is visible in the bottom row of the display, your phone is already set to Automatic search mode.

2. If **Auto** is not visible, press **YES**.
3. Select **Auto** and press **YES**.

The phone is now set to Automatic search mode.

4. To return to standby mode, press **CLR**.

NETWORKS
◀ Searchmode ▶
(Auto)

Note! The order of preference in which the phone selects a network is determined by a list of preferred networks on your SIM card, which you can edit at any time.

Manual Search Mode

The manual search mode means that your phone first searches for the last accessed network. If this is not available, the question **Select network?** appears.

To turn on the manual search mode

1. Scroll to **Networks, YES, Searchmode, YES.**
2. Select **Manual** and press **YES.**
3. To return to standby mode, press **CLR.**

To select a network, see below.

SELECTING A NETWORK

1. Scroll to **Networks, YES, Select net, YES.**
2. If there is more than one network within range, scroll to the network you want and press **YES** to select it.

Display Information

Instead of the full name of a country and a network, an abbreviation is displayed when you use the **Networks** menu. To see the full name of a network, press *.

Together with the network name, you also get the following information in the display:

The display shows...	meaning...
Current	The network is currently being used.
Home	Your home network is within range. You can use it.
Preferred	The name of the network is included in a list of preferred networks on your SIM card. You can use this network.
Forbidden	The name of the network is included in a list of forbidden networks on your SIM card. You are not allowed to use this network, except for emergency calls.
Available	The name of the network is not included in the preferred or forbidden list on your SIM card. You can use this network.
No network	There is no network within range.

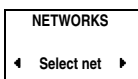
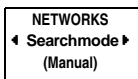

NETWORKS

◀ New Search ▶

To start an automatic network search

- Scroll to **Networks**, **YES**, **New search**, **YES**.

The phone automatically starts searching for a network according to the list of preferred networks stored on your SIM card.

Forbidden Networks

The names of the forbidden networks are stored on your SIM card. If such a forbidden network is within range, it is left out when the phone searches for a network (automatic search mode).

If your home network and a forbidden network come to an agreement that allows you to use the forbidden network, you can select this network even though the message **Forbidden** is displayed.

LIST OF PREFERRED NETWORKS

You can create a list that defines in which order your phone selects a network during automatic network selection, when your home network is not within range.

The number of networks that can be stored in the list depends on your SIM card.

The **Edit list** function lets you review the networks in the list. Apart from re-arranging the order of the networks, you can add new networks to the list and delete networks from it.

To review the list of networks

1. Scroll to **Networks**, **YES**, **Edit list**, **YES**.

The message **Please wait** is displayed.

The name of the first network is displayed. If a network is within range, a ** is also displayed.

2. You can scroll through the other networks in the list using the **LEFT** and **RIGHT** keys.

Note! *To see a network's full name, press **.

To add a network to the list

1. Scroll to **Networks**, **YES**, **Edit list**, **YES**.
2. Scroll to the first free position in the list and press **YES**.

The question **Add net?** appears in the display.

If you scroll to a position that is already occupied, you must press **YES** and then scroll with the **LEFT** or **RIGHT** key until **Add net?** appears.

3. Press **YES** and scroll with the **LEFT** or **RIGHT** key until you find the network you want.

NETWORKS

◀ Edit list ▶

EDIT LIST

Network name

◀ 1 ▶

EDIT LIST
Network name
◀ Erase? ▶

EDIT LIST
Network name
◀ Move? ▶

4. If the desired network does not appear, press **YES** when the question **Other?** appears. Then enter the three-digit country number and the two-digit network number.
5. Finally, to add the network to the list, press **YES**.

To erase a network from the list

1. Scroll to **Networks**, **YES**, **Edit list**, **YES**.
2. Scroll to the network you wish to erase and press **YES**.
3. Select **Erase** and press **YES**.

To re-arrange the list

1. Scroll to **Networks**, **YES**, **Edit list**, **YES**.
2. Scroll to the network you wish to move and press **YES**.
3. Select **Move** and press **YES**.
4. Enter the new position within the list and press **YES**.

Handling More than One Call Simultaneously

Your phone allows you to handle more than one call simultaneously. This means that you can put a call that is in progress on hold, while you make or answer a second call, and then switch between the two calls.

You can also set up a **Conference Call** to have a joint conversation with up to five people. You can put an individual or a group of conference members on hold while you add other people to the conference call. You can also put conference members on hold while you talk to someone privately. See “*Conference Calls*” on page 76.

CALL WAITING SERVICE

To be able to receive a second call, you must turn on the **Call Waiting** service.

To activate the Call Waiting Service

1. Scroll to **Access, YES, Call Waiting, YES**.
2. Select **Activate** and press **YES**.

There may be a short delay before the network responds. In the meantime, the message **Please wait** is displayed. This is followed by the message **Call Waiting ON**.

To cancel the Call Waiting Service

1. Scroll to **Access, YES, Call Waiting, YES**.
2. Select **Cancel** and press **YES**.

Tip! With the **Get status** option, you can check whether the call waiting service is on or not.

MAKING A SECOND CALL WHILE A CALL IS IN PROGRESS

1. Put the current call on hold by pressing **YES**.
The message **1 on hold** is displayed.
2. Enter the number you wish to call or recall it from the phone book.
3. Press **YES** to make the call.

CALL WAITING

◀ Activate ▶



RECEIVING A SECOND CALL WHILE A CALL IS IN PROGRESS

If the **Call Waiting** function is on, you hear a tone in the earpiece if you receive a second call and the message **Call wait** appears in the display. You can do one of the following:

To end the current call and accept the waiting call

1. Press **NO** to end the current call.
The question **Answer?** appears.
2. Press **YES** to answer the waiting call.

To put the current call on hold and answer the waiting call

- Press **YES** to put the current call on hold and answer the waiting call.
The message **1 on hold** appears.

To continue the current call and reject the waiting call

- Press **0** followed by **YES**.
The waiting call is cleared. If the caller's network supports it, the caller hears a busy tone.

Note! If "Divert On busy" is on, the waiting call is diverted to the number you have specified.

WHEN ONE CALL IS ACTIVE AND ONE CALL IS ON HOLD

When you have one active call and one on hold, you can do one of the following:

To switch between two calls

- Press **YES** to switch between the active call and the call on hold.

To end the active call

1. Press **NO** to end the active call.
The message **Retrieve held call?** appears and a beep sounds.
2. Press **YES** to return to the held call or press **NO** to end the held call.

Note! If you do not press **YES** or **NO** within three seconds, the message **Retrieve held call?** disappears from the display. The held call is ended automatically.

Tip! You can automatically end the current call and retrieve the held call by pressing **1** followed by **YES**.



To connect two calls – explicit call transfer

If you have one active call and one on hold, it is possible to connect the two calls.

- Press **4** followed by **YES**.

The two calls are now connected to each other, and you are disconnected from both calls.

Note! *This service may not be available on all networks. For more information, please contact your operator.*

RECEIVING A THIRD CALL

If the **Call Waiting** service is activated, you may receive a third call when you have one active call and a second call on hold. You will hear a tone in the ear-piece and the message **Call Wait** appears in the display. You can do one of the following:

Only one call at a time can be on hold. If you wish to accept the third call, you must end one of the existing calls.

To end the current call and accept the waiting call

- Press **1**, followed by **YES**.

The waiting call becomes active and the held call remains on hold.

To reject the waiting call

- Press **0**, followed by **YES**.

The third call is rejected. If the caller's network supports this function, the caller hear a busy tone.

Note! *If **Divert On busy** is on, the waiting call is diverted to the number you have specified.*

CONFERENCE CALLS

Note! *The Conference Call Service may not be available on all networks. Please contact your operator for more information.*

The Conference call service allows you to have a joint conversation with up to five people. You may put an individual or a group of conference members on hold while you add other people to the conference call. You may also put conference members on hold while you talk to someone privately.

To set up a conference call

1. Call the first person you wish to include in the conference call.
2. Put this person on hold by pressing **YES**.
3. Call the second person you wish to include in the conference call.

4. Press **3**, followed by **YES**, to include the two people in the conference call.

You can now put the conference group on hold and add a third person by repeating steps 2 to 4. It is possible to add up to five persons in this way.

Note! *In the display, the last called number is referred to as call number one, the call before that number two etc.*

If you wish to have a private conversation with one of the members, you can put the other members on hold.

To have a private conversation

1. Press **2**.
2. Press the number of the member you want to have a private conversation with. For example, if you wish to talk to member number three, press **3**.
3. Press **YES**.

To join the member to the conference call again:

- Press **3** and then **YES**.

To release one of the members in a conference call

1. Press **1**.
2. Press the number of the member you want to release. For example, if you wish to release member number three, press **3**.
3. Press **YES** to release the member.

Making a Call While a Conference Call is In Progress

You can put the conference group on hold and make another call. You can then switch between the new call and the conference call.

To put the conference group on hold and make a new call

1. Press **YES** to put the conference call on hold.
2. Enter the number you wish to dial and press **YES**

To switch between the new call and the conference call

- Press **YES**.

To end the new call and return to the conference call

- Press **1** followed by **YES**.

To end a conference call

- Press **NO** to end the conference call.

Knowing the Call Time/ Call Cost

When you are on the phone, the display shows the duration of a call. By using the **Call info** function in the **Settings** menu you can check the time for all calls, both incoming and outgoing. You can also have the call cost or the number of call units displayed by selecting the **Cost** option, provided your network and your SIM card support this feature.

CALL INFORMATION

To set what call information you want to be displayed in the Info menu

1. Scroll to **Settings**, **YES**, **Call info**, **YES**.
2. Select **Time:Outg**, **Time:All** or **Cost**.
3. Confirm your selection by pressing **YES**.

Checking the Time or Cost of the Last Call

You can check the time/cost of the last incoming (or outgoing) call with the **Last call** option in the **Info** menu.

To check time or cost of the last call

- Scroll to **Info** and press **YES**.
Depending on the setting in the **Call info** function in the **Settings** menu, you can use the navigation key to check:
 - The elapsed time of the last outgoing call.
 - The elapsed time of the last incoming call provided you have chosen the **Time:All** option in the **Call info** function in the **Settings** menu.

To check the total time or call cost

- Scroll to **Info**, **YES**, **Tot calls**.
Depending on the settings in the **Call info** function in the **Settings** menu, you can check:
 - The elapsed time of all outgoing calls.
 - The elapsed time of all incoming and outgoing calls.
 - The cost (or the number of call units) of all incoming and outgoing calls.

CALL INFO

◀ Time: outg ▶

INFO

◀ Last call ▶
1:23

To reset the total call time/cost meter

1. Scroll to **Info**, **YES Tot Calls**, **YES**.

The message **Reset?** appears.

2. Press **YES** to reset the meter.

Note! *If you choose the call cost option you must enter your PIN2 to reset the meter.*

DETERMINING THE CALL COST

This menu only appears if you have selected the **Cost** option in the **Call info** function in the **Settings** menu, see below.

- Scroll to the **Info** menu and select **Price**.
 - The **Units** option means that the number of call units is displayed during a call, and in the **Last call** and **Tot calls** functions.
 - The **Price** function lets you enter and vary the price per call unit. The price entered is stored on your SIM card.

To Enter the Price per Call Unit

1. Scroll to **Settings**, **YES**, **Call info**, **YES**.
2. Select **Cost** and press **YES**.
3. Press **CLR** to return to standby mode.
4. Scroll to **Info**, **YES**, **Price**, **YES**, **Units**, **YES**.
5. Enter your PIN2 and press **YES**.

The message **INFO Price Units** appears in the display.

6. Press **YES**.
7. Enter the code for the currency you want e.g. **GBP** for Pound Sterling, and press **YES**.
8. Enter the price per call unit, for example 0.5, and press **YES**. To enter the decimal point, press **#**.
9. Enter your PIN2 and press **YES**.

To Revert to Displaying Call Units

1. Scroll to **Info**, **YES**, **Price**, **YES**.
2. Press **YES** to select **Units**.
3. Press **YES** again to revert to displaying call units.

CREDIT LIMITS FOR CALLS

Provided both your network and your SIM card support this feature, you can enter a total amount of money that can be used for making calls. This could be useful when e.g. you, lend your phone to someone, and do not want their call costs to exceed an amount specified by you. After a call is made, the cost is

INFO
Price
Units

deducted from this amount. When the amount reaches zero, no more calls can be made.

To set a credit limit for calls

1. Scroll to **Info**, **YES** **Credit unlimited**, **YES**, **New Credit**, **YES**.
2. Enter the amount: for example, 30 pounds and press **YES**.
3. Enter your PIN2 and press **YES**.

CREDIT

◀ New credit ▶

Not for Commercial Use
Ericsson Mobile Communications AB

Using Two Phone Lines

If your subscription supports the Two line service, (also called Alternate Line Service, ALS), you can have two different speech lines. This is useful feature if e.g. you, want to use one number for your business calls and one for your private calls.

The two line service may not be available on all networks and may require a separate subscription. Please contact your network operator for more information.

Note! *You can only send and receive text messages (SMS) on line 1.*

SELECTING A LINE

The line currently selected is indicated in the display with the letter 'L' and the number for the selected line. For example, if line two is selected, you will see 'L2' in the display.

Note! *The menu **Change to** only appears if you are using the two line service.*

To change to the line that is not currently selected

1. Scroll to **Change to**.
2. Press **YES** to change to the line displayed in the bottom row.
From now on, all outgoing calls are made on the selected line. You can, however, receive calls on both lines.

Tip! *Instead of accessing the menu system, you can press and hold **2** to change line, provided the phone is in standby mode.*

Receiving a Call on Line 1 or Line 2

When someone calls you, the question **Answer?** is replaced by **Line1?** or **Line2?** depending on which line the person is calling.

Note! *If you are engaged in a call on one line, you must end that call first before answering a call on the other line.*

DIFFERENT SETTINGS FOR EACH LINE

You can have different settings for each line: for example, the tone of the ring signal, call diverts, call bars and call waiting function.

MENU

◀ Change to ▶
Line 2



The call meters in the **Info** menu show the call times (call costs) for the line currently selected.

Changing the Name of the Two Lines

The phone allows you to personalize the names of the two lines. You might, for example, want to call Line 1 “Private” and Line 2 “Work”.

To change the name of a line

1. Scroll to **Settings, YES**.
2. Select **Line 1 Tag** or **Line 2 tag** and press **YES**.
3. Enter the name (maximum twelve characters), using the numeric keys.
4. Press **YES** to confirm the new name.

Calling Card or Credit Card Calls

When making international or long distance calls, you may not want your operator to charge you for these calls on your normal account. If you have a credit card or a calling card, you may want to re-direct the charges to one of those accounts instead. Your phone is all set for making this procedure as easy as possible for you.

You can store two separate card numbers in your phone. These numbers are protected by a four- to eight-digit security code that you choose yourself.

Note! *The Calling card and Credit call feature is network dependent.*

TURNING ON THE CALLING CARD FEATURE

To be able to make Calling cards call, you have to turn on this function.

To activate the calling card feature

1. Scroll to **Access, YES, Call cards security, YES**.
Enter code appears in the display.
2. Enter your security code (the factory set code is **0000**) and press **YES**.
3. Scroll to **Call cards** and press **YES**.
4. Select **On** and press **YES**.

You can change the security code to a code of your own choice. The code can consist of four to eight digits.

To change security codes

1. Scroll to **Access, YES, Call cards security, YES**.
2. Enter your security code (the factory set code is 0000) and press **YES**.
3. Scroll to **Change code** and press **YES**.
4. Enter your new code and press **YES**.

The code can consist of four to eight digits.

5. Confirm your new code when **Repeat new code** appears in the display and press **YES**.

Your security code has now been changed.

STORING CREDIT OR CALLING CARD NUMBERS

Your phone allows you to store two calling card numbers in the phone book menu. This sub-menu is only visible if the Call card function is activated in the Access menu.

To store a credit or a calling card number

1. Scroll to **Phone book, YES, Call card, YES.**
2. Enter your security code and press **YES.**
When you buy the phone the code is set to **0000**. To change security codes, see above.
3. Select card position (**Card 1** or **Card 2**) using the **LEFT** and **RIGHT** keys and press **YES.**
4. Enter the access number (the phone number) to the calling card server. The numbers are entered in the same way as ordinary phone numbers.
5. Press **RIGHT.**
6. Enter the verification code to your calling card server.
7. Press **YES** to store the calling card number.

SELECTING A CARD

If you have two card numbers stored, you must select which card you wish to use before making a Calling/Credit card call.

To select the card you want to use

1. Scroll to **Phone book, YES, Call card, YES.**
2. Enter your security code and press **YES.** (When you buy your phone the code is set to **0000**.)
3. Select the card you wish to use and press **YES.**
Your setting for the card appears.
4. Press **YES** to select the card.

MAKING A CREDIT OR CALLING CARD CALL

1. Enter the number you wish to dial, or retrieve it from the Phone book.
2. To set up the call as a Credit/Calling card call, press and hold **YES.**

The access number to the calling card server is called and during the connecting phase, you are prompted to send the called number (the number or the person you want to call) and the verification code, in the order chosen by you (see above).

To send the called number and the verification code during the connecting phase, press **YES** when the display shows **Send**, or wait a few seconds and your phone sends them automatically.

Sending and Receiving Fax and Data calls

If you have a SIM card that does not support separate fax and data numbers, you need to turn on the data menus. When you turn on the **Data menus** two new menus appear; the menu, **Speech then fax** appears before the **Info** menu when you scroll with the **LEFT** and **RIGHT** keys. The menu **Next call type** appears after the **Info** menu.

Note! All fax and data calls are initiated from the appropriate computer software.

To turn the data menus on or off

1. Scroll to **Settings, YES, Data menus, YES.**

The current status (**On** or **Off**) is displayed on the bottom row.

2. Select **On** or **Off** and press **YES.**

DATA MENUS

◀ Off ▶

NEXT CALL TYPE

This function allows you to decide which type the next incoming call will be, i.e. fax, data, speech then fax or fax then speech. You only see this menu if your phone detects that you do not have separate numbers for data, fax and speech. Once you have set your phone for a specific incoming call, it stays like this until you change it back. The normal setting is speech.

To set the phone for a certain type of call

1. Scroll to **Next call type** (the Data menu must be turned on) and press **YES.**
2. Select the type of call you are going to receive and press **YES.**

MENU

Next

◀ call type ▶

Some Useful Tools

ALARM

The phone has an alarm function. When it is on, an icon in the shape of a bell (🔔) is shown next to the current time in the display.

The alarm rings at the set time even if the phone is turned off. The illumination of the keys and the display flash. The volume of the alarm signal depends on the setting of the ring signal.

The alarm rings for 60 seconds and is repeated every nine minutes if you do not turn it off. After 60 minutes, the repeat function is turned off.

To set the alarm

1. Scroll to **Clock, YES, Set alarm, YES, New time, YES**.
2. Enter the time in hours and minutes.
3. Press **YES** to confirm the alarm setting.

Note! If you choose the 12-hour format in the “Clock mode” function, you can alternate between am and pm by pressing * or #.

To turn the alarm signal off

1. Press any key to turn the alarm off when it rings.
2. If you do not want the alarm to be repeated, press **YES**.

To turn the alarm off

1. Scroll to **Clock, YES, Set alarm, YES**.
2. Select **Off** and press **YES**.

CALCULATOR

The phone’s built-in calculator can add, subtract, divide and multiply.

To use the calculator

In this example we are going to divide 134 by 32.

1. Scroll to **Calculator** and press **YES**.
2. Enter 134.
3. Scroll with the **LEFT** or **RIGHT** key to the division sign (/), and press **YES**.
4. Enter 32.

SET ALARM
(09:30)
_ -- -

MENU
◀ Calculator ▶

5. Scroll with the **LEFT** or **RIGHT** key to the equal sign (=) and press **YES** to get the answer.

You can also press **#** to get the answer.

6. To clear the display, press **CLR**.

To enter a decimal point

- Press *****.

To multiply

- Press ***** twice.

Ericsson Mobile Communications AB
Not for Commercial Use

son Mobile Communications AB
for Commercial Use

GSM PRO

GSM Pro 90

Not for Commercial Use
Ericsson Mobile Communications AB

GSM Pro

Note! *The features described in this chapter require a special subscription that supports GSM Pro. For more information about GSM Pro, please contact your network operator. Some network operators may choose to use a different name for GSM Pro. For more information about GSM Pro, please see this location on the web: <http://www.ericsson.se/gsmpro>.*

The R250s PRO is the first mobile phone which supports GSM Pro. GSM Pro is an extended feature of the GSM network which gives the user access to most of the functions found today in various Private Mobile Radio (PMR) and Public Access Mobile Radio (PAMR) networks.

With a R250s PRO and a GSM Pro subscription you get access to all the regular GSM network services and most PMR and PAMR services, such as group calls, call monitoring and alert calls.

GROUP CALLS

Group calls allows all members of a specified group to be reached with a single call. With a GSM Pro subscription, group calls are now available on the GSM network.

In a group call, all participants can listen to and talk to each other. The group call features and the Push-To-Talk mode give GSM Pro a walkie-talkie-like function, that is a key feature for PMR and PAMR users.

A group number is a special number that makes it possible to call all group members at the same time with a single call.

Push-To-Talk Mode

Group calls are preferably made and received in “Push-To-Talk mode”, although group calls can be made and received in phone mode.

When you want to speak you press and hold the **PUSH-TO-TALK** button on the left side of the phone, see “*Overview*” on page 4. When you finish talking you release the **PUSH-TO-TALK** button, to let other group members speak.

When you release the Push-To-Talk button the microphone is muted. This is to avoid disturbing background noise during a call.

Mode Switch Selector

The R250s PRO has a mode switch selector on the right side of the phone, see “Overview” on page 4, which you use to switch between phone and Push-To-Talk mode.

When you switch modes the phone gives out a warning tone. You can switch modes at any time: when the phone is in standby, when receiving a call and during a call.

To switch between phone and Push-To-Talk mode

- Slide the **MODE SWITCH** upwards to go to Push-To-Talk mode.
- Slide the **MODE SWITCH** downwards to go to phone mode.

When you switch modes the phone sends out a warning signal.

Earpiece volume

When the phone is set to Push-To-Talk mode, the earpiece/loudspeaker volume increases significantly. You should not hold the phone close to your ear as this may damage your hearing. Hold the phone in front of your face, about 10–30 centimetres away, and speak in the direction of the microphone.

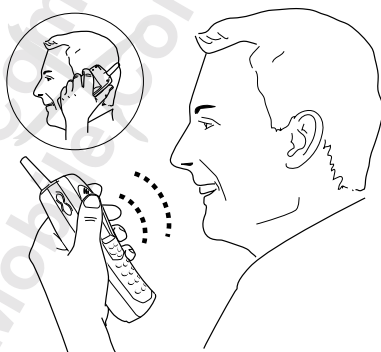

To set the earpiece volume

1. Scroll to **Settings, YES, Ear volume, YES.**

The current mode, **Phone** or **Pushtotalk**, is displayed on the middle row.

2. Use the **LEFT** arrow key to decrease the volume.

Use the **RIGHT** arrow key to increase the volume.

3. Press **YES** to confirm your setting.

Tip! During a call you can use the volume keys on the side of the phone to adjust the volume.

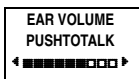

ALERT CALLS

The R250s PRO is equipped with an **ALERT BUTTON**, located on the top of the phone next to the antenna. See “*Overview*” on page 4. Alert calls are easily made by pressing and holding the alert button for one second. If the call cannot get through the phone automatically re-dials the number up to ten times.

When you buy your phone the alert number is set to the international emergency number 112. This number can be changed if you prefer another alert number. This may be useful if e.g. you work in an area where your own organization’s rescue service can reach you faster.

For more information on how to change the alert number see “*Alert Button*” on page 46.

PHONE BOOK

Note! *The talk group numbers are provided by your service administrator. For more information, please contact your service administrator.*

The phone book makes it easy to set up a call to your talk groups. Instead of having to remember the phone number and entering it by using the keypad, you simply recall the number from the phone book by pressing and holding the **PUSH-TO-TALK** button when the phone is in standby. When you find the number you want to call, press **YES** to make the call.

The talk group numbers are stored in the same phone book as the one you use for storing your own, personal phone numbers. See “*Your Personal Phone Book*” on page 33. This means that you may not be allowed to store your personal phone numbers in the memory positions used by your service administrator. If you try to store a phone number in a position that you are not allowed to use, you are prompted to store the number in another position. For more information on how to store phone numbers see “*Storing a Number Together with a Name*” on page 35.

MAKING AND RECEIVING GROUP CALLS

Making and receiving group calls is similar to making and receiving ordinary mobile phone calls.

Note! *We recommend that you set the phone to Push-To-Talk mode before you make or receive a group call.*

You can only call a group of which you are a member.

To make a group call

1. Press **CLR** to go to standby (if you are not already in standby).
2. Press and hold the **PUSH-TO-TALK** button to enter the phone book menu and find the number you want to call.
3. When you find the number, press **YES** to make the call.
The display shows **Calling** followed by **Connecting**.
The ringing tone is heard until a group member answers the call.
4. Press the **PUSH-TO-TALK** button to talk to the other group members.
5. Release the **PUSH-TO-TALK** button when you finish talking, to let other group members talk.
6. Press **NO** when you want to end the call.
The call is ended and all group members are disconnected.

Note! *You can also call a number by entering it on the keypad and then press **YES**.*

Making an Alert Call

1. Press and hold the **ALERT BUTTON** for one second.
The call is set up and the dialled number is shown in the display (the pre-set number is the international emergency number 112.)
If the call cannot get through, the phone automatically re-dials the number up to ten times.
2. Press **NO** to end the call.

Note! *The alert button function must be on. If you change the pre-set alert number (112), you must insert a SIM card and enter the PIN code (if the card is locked). Otherwise the pre-set alert number (112) will be dialled and not the number you have specified.*

You can make an emergency call by dialling the number in the same way as when making an ordinary call.

To make an emergency call

1. Enter 112 (the international emergency number).
2. Press **YES**.
The display shows **Emergency**.
3. Press **NO** to end the call.

Note! *Some network operators may require that a SIM card has been inserted into the phone and, in some cases, that a PIN code has been entered as well. Some networks may not use the international emergency number 112.*

Receiving a Group Call in Push-to-Talk Mode

An incoming group call is answered automatically, the phone sends out a warning tone and the voice of the calling party will be heard in the loud-speaker.

Note! *The phone must be set to Push-To-Talk mode to answer a group call automatically. If the phone is set to phone mode, slide the mode switch upwards to Push-To-Talk mode when you receive a group call. The call is then answered automatically.*

To receive a group call

1. The incoming group call is answered automatically, the phone emits a warning tone and the voice of the calling party is heard in the loudspeaker.
 - The group call cannot be rejected by pressing **NO**.
2. If you want to speak press and hold the **PUSH-TO-TALK** button.
3. Release the **PUSH-TO-TALK** button when you finish talking.
4. Press **NO** when you want to leave the group call.

Note! *If your GSM Pro SIM card has been programmed to “Auto answer all calls”, all calls are answered automatically (provided the phone has been set to Push-To-Talk mode). If the incoming call is an ordinary phone call, this means that you have to press the Push-To-Talk button, or switch to phone mode, to be able to talk to the other person.*

If your SIM card has been programmed to “Auto Answer Group”, the procedure for answering a call, may not work exactly as described above.

For more information on your SIM card settings, please contact your service administrator.

Receiving a Group Call in Phone Mode

If you receive a group call and the phone is set to phone mode, you can do one of the following:

- Slide the **MODE SWITCH** upwards to **Push-To-Talk** mode to automatically answer the call.
- Press **YES** to answer the call in phone mode.

If you answer a group call in phone mode, the microphone will be open during the whole conversation, i.e. you do not have to press the **PUSH-TO-TALK** button when you are requested to answer.

- Press **NO** when you want to end the call.

Receiving an Ordinary Phone Call in Push-To-Talk Mode

If the incoming call is not a group call, i.e. the call is an ordinary phone call, and your phone has been set to auto answer group, then the phone will ring as normal. To answer the call do one of the following:

- Slide the mode switch downwards to **phone** mode to automatically answer the call.
- Press **YES** to answer the call in **Push-To-Talk** mode.

If you answer the call in **Push-To-Talk** mode, you need to press the **PUSH-TO-TALK** button when you want to speak to the person on the other end of the line.

- Press **NO** when you want to end the call.

Note! *If your GSM Pro SIM card has been programmed to “auto answer all calls”, an incoming phone call will be answered automatically. To be able to speak to the person at the other end of the line, you need to press the Push-To-Talk button or switch to phone mode.*

DURING A GROUP CALL

During a group call you can listen to the conversation without having to press any key. During a conversation you may receive a second call, if **call waiting** is on, or you can put an ongoing call on hold and make a second call.

Call Monitoring

The call monitoring function allows you to listen passively, (provided the phone is set to Push-To-Talk mode), to a group conversation, without having to press any keys. This is a practical way of receiving information from other group members while continue working.

Re-entry

If you are disconnected during a call, e.g. due to poor radio signalling or if you voluntarily left the call, the re-entry function lets you re-enter the group call by dialling the talk group number.

To re-enter a group call

1. Recall the number from the phone book or enter the number by using the keypad.
2. Press **YES** to call the number and re-enter the ongoing call.

The other group members will be notified of you entering the call.

Making an Alert Call During an Ongoing Group Call

You can make an alert call during an ongoing group call. The R250s PRO will disconnect the ongoing group call and connect to the pre-set alert number.

To make an alert call during an ongoing group call

1. Press and hold the **ALERT BUTTON** for one second.

The call is set up and the number dialled is shown in the display.

2. Press **NO** to end the call.

Group Conversation Limit

The group conversation limit allows the service administrator to set a time-limit for group calls. This is a useful feature if the initiator of the call should forgets to end the call. Please contact your service administrator for more information.

HANDLING MORE THAN ONE CALL

Your phone allows you to handle more than one call simultaneously. This means that you can put a call that is in progress on hold, while you make or answer a second call, and then switch between the two calls. See *“Handling More than One Call Simultaneously”* on page 74.

GSM PRO WIRELESS DISPATCH CONSOLE

The GSM Pro Wireless Dispatch Console is an additional product for GSM Pro users. A dispatch console located in an office e.g. makes it easy to communicate with and manage personnel in the field.

The Wireless Dispatch Console consists of a PC, dispatcher software, a R250s PRO and a headset. The software runs under standard Windows 95/98/NT operating system and can co-exist with other Windows programs. The software supports ordinary phone calls, group calls, text messages (SMS) and special display of alert calls.

As the name implies, the Wireless Dispatch Console requires no fixed telephone lines for its operation and is therefore suited for both fixed and mobile equipment.

For more information, please contact your GSM network operator.

ADDITIONAL INFORMATION

Accessories	98
Troubleshooting	102
Ericsson Mobile Internet	104
Quick Keys	105
Technical Data	106
Glossary	107
Guidelines for Safe and Efficient Use	112
Warranty	116
Declaration of Conformity	118
Index	119

Accessories

By using the phone with Ericsson original accessories, you get access to a wide range of extra features, in addition to when the phone is used separately.

HANDSFREE CALLING

By using the Ericsson portable or car handsfree solutions, you can be on the phone without using your hands to hold it. You can change the settings for the handsfree-related functions so that they fit your own requirements.

Ericsson car handsfree, is specially designed to fit in with your car interior. The car handsfree supports the functions of the mobile phone, making it easy and convenient to be on the phone while driving.

Note! *In some countries it is required that you use a vehicle handsfree solution, if you want to use your mobile phone while driving. Please check the laws and regulations on the use of telephones in the areas where you drive.*

Answering Mode

The menu **Answering mode** includes two functions: **Any key** and **Auto**, which are useful when you use the phone with handsfree equipment.

- The **Any key** function:
If you use the phone with handsfree equipment and this function is turned on, you can answer an incoming call by pressing any key, except **NO**.
- The **Auto** function:
If you choose the automatic answering mode, an incoming call is answered automatically after one ring signal, if the phone is used with handsfree equipment.

To select answering mode

1. Scroll to **Settings, YES, Answering mode, YES**.
2. Select **Any key** or **Auto** and press **YES**.
3. Select **On** and press **YES**.

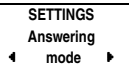

Other Handsfree-Related Settings

Apart from the settings mentioned above, each of the settings below can be specified separately when you have your R250s PRO connected to handsfree equipment and when you use the phone as a handheld unit:

- Ring level
- Earpiece volume
- Ring type
- Display light

This means that if you make one of these settings when the phone is connected to handsfree equipment, the settings when it is handheld are not affected and vice versa.

To change a setting

1. Connect the phone to the handsfree equipment.
2. Change the setting according to the instructions in the chapter "Personalizing Your Phone" on page 46.

DESK/WALL STAND

The desk/wall stand for the R250s PRO serves both as a charger and a holder for the phone. When the battery runs low just place the phone in the desk/wall stand to charge it (the charger must be connected to the desk/wall stand).

The desk/wall stand can be placed on e.g. a table or attached to the wall. The desk/wall stand consists of two pieces that can be separated (see pictures).

You need to separate and rotate the two pieces to change between desk and wall stand modes.

Connecting the charger

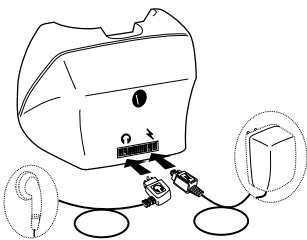

1. Place the desk/wall stand on a table or attach it to the wall.
2. Connect the charger to the mains.
3. Connect the other end of the cable to the desk/wall stand. The flash symbol on the plug must face upwards.
4. Place the phone in the desk/wall stand to charge the phone.

Desk

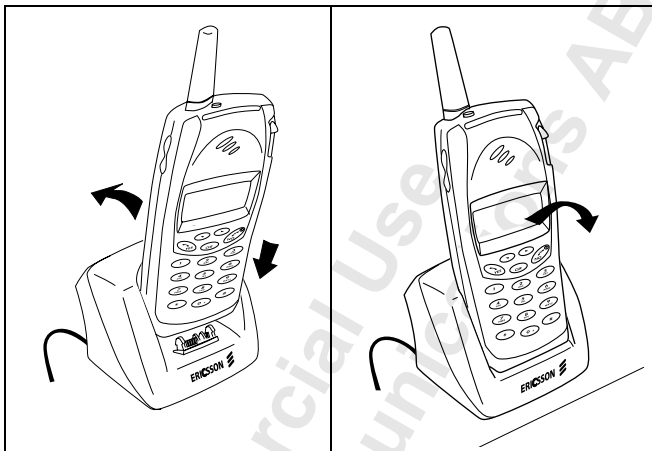

Wall

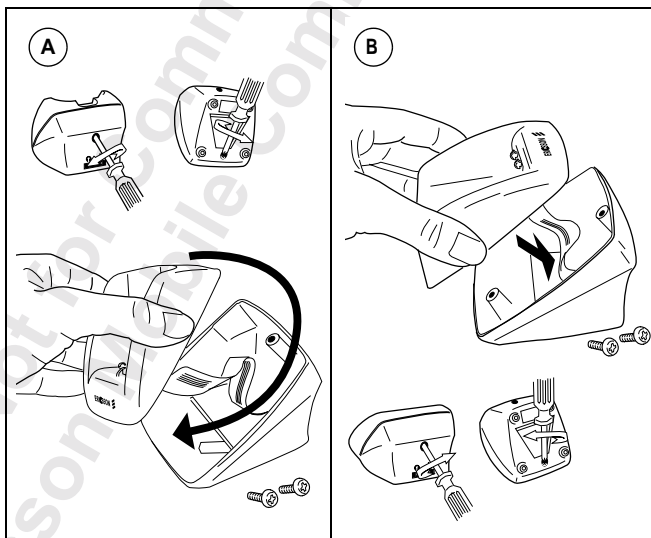

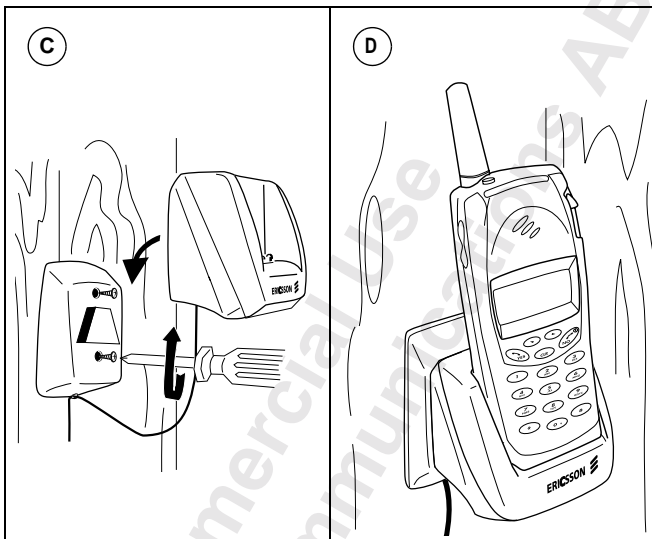

Not for Commercial Use
Ericsson Mobile Communications AB

Troubleshooting

This chapter lists some problems that you might encounter while using your phone. Some problems require that you call your service provider, but most of the problems you encounter are easy to correct yourself.

ERROR MESSAGES

Insert
card

Insert card

There is no SIM card in the phone. Insert a SIM card. See “*The SIM Card*” on page 6.

Searching

16:21

Searching

If the message **Searching** remains in the display, you are within range of a network but you are not allowed to use it. However, in an emergency, some operators allow you to call the international emergency number 112. See “*Making and Receiving Calls*” on page 19.

No network

No network

There is no network within range or the received signal is too weak. You have to move to get a signal that is strong enough.



Tip! You can also try to change to the longer, high gain antenna.

Wrong
PIN

Wrong PIN, Wrong PIN2

You entered your PIN incorrectly.

- Enter the correct PIN or PIN2, and press **YES**.

Enter
PIN

Matching error

When you want to change a security code (for example PIN) you have to confirm the new code by entering it again. The two codes that you have entered do not match. See “*Security for Your Phone and Subscription*” on page 64.

PIN
Blocked.
Unblock?

PIN Blocked. Unblock?

You entered your PIN incorrectly three times in a row. To unblock see “*Security for Your Phone and Subscription*” on page 64.

BLOCKED
Contact card
provider

Blocked Contact card provider

You entered your personal unblocking key (PUK) incorrectly 10 times in a row. Contact your network provider or service operator.

Phone
locked

Phone locked

The phone is locked. To unlock the phone, see “*Security for Your Phone and Subscription*” on page 64.

Enter
lock code

Enter lock code

Your phone comes with the default security code, **0000**. You can change it to any three- to eight-digit personalized code. See “*Security for Your Phone and Subscription*” on page 64.

No Indication of Charging

When the battery is totally run down and you start charging it, you get no indication of charging.

THE PERSON AT THE OTHER END CAN NOT HEAR YOU

The phone is set to Push-To-Talk mode. Press and hold the Push-To-Talk button on the left side of the phone, when you want to talk to the person (or talk group) at the other end. See “*Overview*” on page 4.

The microphone has a hole and if by chance water comes into the hole, your voice may sound unclear to the receiver. To clear the water from the microphone hole, hold the phone upright and tap on it repeatedly on the reverse side.

PHONE DOES NOT COME ON

Handheld Phone

- Recharge or replace the battery.

Handsfree Phone in Vehicle

- Make sure that the phone is properly inserted into its holder.
- Check the fuse.

Ericsson Mobile Internet

When you are on the move and in need of communication and information, the Mobile Internet is the answer.

The Mobile Internet is a service supplied by Ericsson to make it easier for you to communicate and receive information quickly, wherever you are. It gives you access to various messaging services, on-line customer services, user manuals and other useful information. With the Mobile Internet you can also download communications software to ensure you get the best out of your Ericsson products.

The Ericsson Mobile Internet address is [tap/mobile.ericsson.com/mobileinternet](http://mobile.ericsson.com/mobileinternet)

Quick Keys

Several keys on your phone can be used to optimize the phone's functions and decrease the number of times you need to press a key. Some of the key combinations demand that your phone is in a certain mode and some can be made from the standby mode.

The table below describes some of the most useful key combinations.

To...	Do this:	Mode:
mute the microphone	press and hold CLR . If you are using a standard SIM card you can also mute the microphone by pressing the Push-To-Talk button.	when on the phone
reject a call	Press NO or double-click on the volume keys up or down.	when receiving a call
quickly access phone book	press and hold the Push-To-Talk button.	when in standby
answer a waiting call and put an ongoing call on hold.	Press YES	
switch between an active call and a call on hold	Press YES	during a call
quickly access voice mail	press and hold 1	when in standby
reach second letter	press and hold the upper volume key and press the desired numeric key	when entering letters
reach third letter	press and hold the lower volume key and press the desired numeric key	when entering letters
speed dial	press 1 – 9 and YES	when in standby
move three lines forward	press 3	when reading a message
return to beginning of message	press and hold LEFT arrow key	when reading a message

Technical Data

General

Product name	R250s PRO
System	GSM 900/GSM1800
SIM card	Small plug-in card, 3V or 5V type, supports GSM Pro SIM cards.
Type number	1100802-BV
Battery	4 Volt/1600mAh

Dimensions

Size	148 x 59 x 32 mm
Weight with battery	Approx. 325 g

Ambient temperatures

Max	+55 C
Min	-20 C

Glossary

Advice of Charge

(or AoC) enables you to monitor the cost of calls made from your mobile phone. Details of the last call and total calls made are shown in the phone display.

Area Information

(or AI) is a service that allows you to receive messages about pre-set topics i.e. weather forecasts, road reports, etc. To use this service, it must be supported by your network.

Calling Line Identification

(or CLI) shows the number of the person calling you in your mobile phone display. You can then make an informed choice as to whether or not to take the call. Bear in mind that not all numbers can be displayed. To use this service, it must be supported by your network.

Call Barring

enables you to restrict or bar certain or all types of calls to and from your mobile phone, i.e. outgoing calls, outgoing international calls, incoming calls. Barring is activated with a personal code. To use this service, it must be supported by your network.

Divert

enables you to forward calls to another number, for example your voice mail or home phone.

DTMF or Touch Tone

Dual Tone Multi Frequency signal – codes sent as tone signals. Used for telephone banking, for accessing an answering machine, etc.

Dual Band GSM 900/1800

The Ericsson R250s PRO is a dual band phone, which means that you can use your phone on two different kinds of networks – the GSM 900 and the GSM 1800 (also called PCN or DCS 1800) systems.

A dual band phone that combines the two standards can use both frequencies. This increases capacity in densely populated urban areas, and consequently

improves the coverage offered by your network operator. It also offers you enhanced international roaming, thanks to the additional networks now available when you are out travelling.

The switching between the two systems is done automatically and seamlessly, which means that you can use your phone without ever having to consider which system is best at the time. This is taken care of by the networks. However, you should note that the functions offered and the network coverage differ depending on your choice of operator and/or subscription.

Enter

is used for keying in letters or numbers from the keypad.

Fixed Dialling Numbers

enables you to allow only numbers beginning with certain pre-defined numbers to be dialled from your mobile phone. The service is activated by PIN2. To use this service, it must be supported by your network.

Fixed Incoming Calls

enables you to allow only numbers beginning with certain pre-defined numbers to be received on your mobile phone. The service is activated by PIN2. To use this service, it must be supported by your network.

Full Duplex

in handsfree equipment means that both parties on the phone can talk at the same time. The opposite is simplex mode when one party talks and the other must wait for his/her turn.

Fax Class

Standards for fax transmission are set as classes. Class I and II allow data transfer speeds of between 2400 to 9600 bps.

Group calls

Group calls allows you to call all members of a specified group with one single call. Group calls requires a subscription which supports GSM Pro.

GSM 900

GSM is the world's most widely used digital network, now operating in over 100 countries around the world, particularly in Europe and Asia-Pacific.

The Global System for Mobile Communications is the most widely used digital mobile phone system. The GSM systems family also includes GSM 1800 and GSM 1900. There are different phases of roll-out for the GSM system and GSM phones are either phase 1 or phase 2 compliant.

GSM 1800

also known as DCS 1800 or PCN, is a digital network working on a frequency of 1800 MHz. It is used in Europe and Asia-Pacific.

GSM Pro

GSM Pro is an extended feature of GSM which gives the user access to many of the features found today in different Public Mobile Radio and Public Access Mobile Radio networks, such as group calls, alert calls and call monitoring. GSM -Pro requires a special subscription.

International sign (+)

mobile phone (+) sign that automatically adds the correct international code in front of a telephone number when dialling out of a country. You then have to add the code of the country you are calling.

International Roaming

a mobile phone feature that allows you to switch between networks offering coverage abroad. Your mobile phone automatically selects a network or system (your home network), but if it is not in range or unavailable, it selects another system. International roaming is based on agreements between network operators in different countries.

Line 1/Line 2

see Two Line Service below.

Menu System

is the easiest way to access all the phone's functions. The menus are arranged to be accessed and viewed when scrolling with the arrow keys.

Network

a mobile phone network or system consists of a network of cells. A radio base station serves each cell from which calls are forwarded to and received from your mobile phone by wireless radio signals.

Operator

To be able to use your phone, you need a subscription to a network. You get this subscription from a network operator, together with a SIM card that you need to use with your phone.

Phone Book

a memory in your mobile phone where phone numbers can be stored and accessed by name (alpha memory search) or position.

PIN

Personal Identification Number – a code used for all GSM-based phones to establish authorization for access to certain functions or information. The PIN code comes with your subscription.

PIN2

Personal Identification Number 2 – an authorization code which is used only for special services.

PUK

Personal Unblocking Code – used to unlock a blocked SIM card. This comes with your subscription.

Push-To-Talk Mode

When the phone is set to Push-To-Talk mode, all calls are carried out in semi-duplex. This means that the microphone is muted until the user presses a “Push-To-Talk” button. This is a useful function to avoid disturbing background noise during a group call.

Roaming

Within your home network, this means that your mobile phone automatically sets up communication procedures with different radio base stations when on the move.

Semi-Duplex

In handsfree equipment, full duplex means that the connection is open for both parties to talk simultaneously. The opposite, simplex, is when it is open to one at a time. Semi-duplex gives close to, but not complete, duplex functionality.

Service Provider

a company that provides services and subscriptions to mobile phone users.

Short Message Service

(or SMS) allows messages of up to 160 characters to be sent and received via the network operator’s message centre to your mobile phone. Messages are stored if the phone is off or out of reach ensuring that they reach you. To use this service, it must be supported by your network.

Scroll

pressing the left or right arrow key to move between the menus.

Select

scrolling to a menu then pressing the **YES** key on the phone.

SIM card

Subscriber Identity Module card - a card that must be inserted in any GSM-based mobile phone. It contains subscriber details, security information and memory for a personal directory of numbers. The card can be a small plug-in type or credit card-sized but both types have the same functions.

SMS

see *Short Message Service* above.

Subscription

is the contract that you have with the service/network provider. To use your phone, you need to have a subscription to a network. You get a SIM (Subscriber Identity Module) card with your subscription. The services included in your subscription depend on your choice of operator and/or subscription. So some of the services and functions described in this manual may not be accessible to you. If you want a complete list of the services included in your subscription, please contact your network operator.

Two Line Service

(also called Alternate Line Service, ALS) enables you to have two lines and two different phone numbers on one subscription for your mobile phone. This makes it possible to have separate numbers for business and personal calls. To use this service, it must be supported by your network.

Guidelines for Safe and Efficient Use

GENERAL

Your mobile phone is a radio transmitter and receiver. When the phone is turned on, it receives and transmits radio frequency (RF) energy. Depending on the type of mobile phone you have bought, it operates in different frequency ranges and employs commonly used modulation techniques. The system that handles your call when you are using your phone controls the power level at which your phone transmits.

EXPOSURE TO RADIO FREQUENCY ENERGY

The International Commission on Non-Ionizing Radiation Protection (ICNIRP), sponsored by the World Health Organization (WHO), published a statement in 1996 which sets limits for exposure to RF fields from handheld mobile phones. According to this statement, which is based on the available body of research, there is no evidence that mobile terminals meeting the recommended limits can cause any adverse health effects. All Ericsson telephones conform to the ICNIRP recommendations and international exposure standards, such as:

- CENELEC European Pre-standard ENV50166-2
- ANSI/IEEE C95.1-1992 (USA, Asia-Pacific)

If you want to limit RF exposure even further, you may choose to control the duration of your calls and operate your phone in the most power efficient manner.

EFFICIENT PHONE OPERATION

How to use your phone for optimum performance with minimum power consumption:

- In the Phone Mode, hold the phone as you would any other telephone. While speaking directly into the mouthpiece, angle the antenna in a direction up and over your shoulder.
- In the Speakerphone Mode, hold the phone in front of your face about 30 – 50 cm away and speak in the direction of the phone.

- In the Push-to-talk Mode, hold the phone in front of your face about 10 – 30 cm away and speak in the direction of the phone.
- **Do not** hold the phone close to your ear while the phone is in Speakerphone or Radio Mode.
- **Do not** hold the antenna when the phone is in use. Holding the antenna affects call quality, may cause the phone to operate at a higher power level than needed and shorten talk and standby times.

ANTENNA CARE AND REPLACEMENT

- **Do not** bend the antenna since it is sensitive and this will reduce its performance.
- **Do not** use the phone with a damaged antenna. Take your phone to a qualified service centre for repair.
- **Do not** use an antenna designed for any other type of telephone than the one you have bought. Unauthorized antennas, modifications, or attachments could damage the phone and may violate the appropriate regulations and will void the warranty and Ericsson can not guarantee the phone being water resistant.

BATTERY

- The phone is **not** water-resistant when the battery is removed.
- **Do not** use the phone with a damaged battery. Use only the designated Ericsson battery.

DRIVING

Check the laws and regulations on the use of telephones in the areas where you drive. If you are going to use your mobile phone while driving:

- Give full attention to driving.
- Use handsfree operation, if available.
- Pull off the road and park before making or answering a call if driving conditions so require.

RF energy may affect some electronic systems in motor vehicles. In addition, some vehicle manufacturers forbid the use of mobile phones in their vehicles. Check with your vehicle manufacturer's representative to be sure that your phone will not affect the electronic systems of your vehicle.

ELECTRONIC DEVICES

Most modern electronic equipment, for example equipment in hospitals and cars, is shielded from RF energy. However, RF energy from telephones may affect some electronic equipment.

- **Turn off** your phone in health care facilities when regulations posted in the areas instruct you to do so.
- **Do not** use your mobile phone near medical equipment without requesting permission.

Mobile phones may affect the operation of some implanted cardiac pacemakers, equipment for people with hearing impairments and other medically implanted equipment. Pacemaker patients should be aware that the use of a mobile phone very close to a pacemaker might cause the device to malfunction. Avoid placing the phone over the pacemaker, i.e. in your breast pocket. When using the phone, place it at the ear opposite your pacemaker. If a minimum distance of 15 cm is kept between the phone and the pacemaker, the risk of interference is limited. Contact your cardiologist for more information.

AIRCRAFT

- **Turn off** your phone before boarding any aircraft.
- **Do not** use it on the ground without crew permission.

To prevent interference with aircraft systems, you must not use your phone while the plane is in the air.

POWER SUPPLY

- Connect AC (Power supply) only to designated power sources as marked on the product.
- Make sure the AC (Power Supply) is dry and clean before you plug it in.
- To reduce risk of damage to the electric cord, remove it from the outlet by holding onto the AC adapter rather than the cord.
- Make sure the cord is located so that it will not be stepped on, tripped over or otherwise subjected to damage or stress.
- To reduce the risk of electric shock, unplug the unit from any power source before attempting any cleaning, then use a soft, damp cloth.

BLASTING AREAS

Turn off your mobile phone when in a blasting area or in areas posted “turn off two-way radio” to avoid interfering with blasting operations. Construction crews often use remote control RF devices to set off explosives.

POTENTIALLY EXPLOSIVE ATMOSPHERES

Turn off your phone when in any area with a potentially explosive atmosphere. It is rare, but your phone or its accessories could generate sparks. Sparks in such areas could cause an explosion or fire resulting in bodily injury or even death.

Areas with a potentially explosive atmosphere are often, but not always, clearly marked. They include fuelling areas, such as petrol stations, below deck on boats, fuel or chemical transfer or storage facilities, and areas where the air contains chemicals or particles, such as grain, dust, or metal powders.

Do not transport or store flammable gas, liquid, or explosives in the compartment of your vehicle, that contains your phone and accessories.

CHILDREN

Do not allow children to play with your phone since they could hurt themselves or others or accidentally damage the phone.

PRODUCT CARE

Although the phone is resistant to rain and running water, do not unnecessarily subject the phone to water. If you need to wash your phone, it is recommended that you do it gently in cold water under a water tap. Make sure that your battery is properly connected, the antenna is properly screwed on and that all accessories are removed before you wash your phone. Do not use any detergent or washing powder.

- Do not immerse the product in water.
- Do not expose your product to liquids other than water.
- Do not expose your product to extreme temperatures.
- Do not use any other accessories than Ericsson originals. Failure to do so may result in loss of performance, fire, electric shock or injury, and will void the warranty.
- Do not attempt to disassemble the product. Doing so will void the warranty. This product does not contain consumer serviceable components. Service should be performed by Authorized Service Centres only.
- The phone will not withstand dust, moisture or rain if the battery and/or the antenna are not properly connected.
- Removal of the battery, SIM card and antenna should be done under dry conditions. Make sure that no moisture gets into the phone.
- To avoid damaging the accessory, make sure that the phone is dry before connecting the phone to any accessory.

Warranty

Thank you for purchasing this Ericsson Product. To get maximum use of the features of your new product we recommend that you follow a few simple steps:

- Read the Guidelines for safe and efficient use.
- Read all the terms and conditions of your Ericsson Warranty.
- Save your original receipt. You will need it for warranty repair claims.

Should your Ericsson Product need warranty service, you should return it to the dealer from whom it was purchased or contact your local Ericsson helpdesk to get further information.

OUR WARRANTY

Ericsson warrants this Product to be free from defects in material and workmanship at the time of its original purchase by a consumer, and for a subsequent period of one (1) year.

All accessories for the Product are covered by a warranty for a period of one (1) year from the date of its original purchase by a consumer.

WHAT WE WILL DO

If, during the warranty period, this Product fails to operate under normal use and service, due to improper materials or workmanship, Ericsson subsidiaries, authorised distributors or authorised service partners will, at its option, either repair or replace the Product in accordance with the terms and conditions stipulated herein.

CONDITIONS

1. The warranty is valid only if the original receipt issued to the original purchaser by the dealer, specifying the date of purchase and serial number, is presented with the product to be repaired or replaced. Ericsson reserves the right to refuse warranty service if this information has been removed or changed after the original purchase of the product from the dealer.
2. If Ericsson repairs or replaces the Product, the repaired or replaced Product shall be warranted for the remaining time of the original warranty period or for ninety (90) days from the date of repair, whichever is longer. Repair or replacement may be via functionally equivalent reconditioned

units. Replaced faulty parts or components will become the property of Ericsson.

3. This warranty does not cover any failure of the Product due to normal wear and tear, misuse, including but not limited to use in other than the normal and customary manner, in accordance with Ericsson's instructions for use and maintenance of the Product, accident, modification or adjustment, acts of God, improper ventilation and damages resulting from liquid.
4. This warranty does not cover product failures due to repair installations, modifications or improper service performed by a non-Ericsson authorised service workshop or opening of the product by non-Ericsson authorised persons.
5. The warranty does not cover product failures which have been caused by use of non-Ericsson original accessories.
6. Batteries are warranted only if battery capacity falls below 80% of rated capacity. This warranty becomes void if the batteries are charged by non-Ericsson original battery chargers.
7. Tampering with any of the seals on the products will void the warranty.
8. **THERE ARE NO OTHER EXPRESS WARRANTIES, WHETHER WRITTEN OR ORAL, OTHER THAN THIS PRINTED LIMITED WARRANTY. ALL IMPLIED WARRANTIES, INCLUDING WITHOUT LIMITATION THE IMPLIED WARRANTIES OR MERCHANTABILITY OR FITNESS FOR A PARTICULAR PURPOSE, ARE LIMITED TO THE DURATION OF THIS LIMITED WARRANTY. IN NO EVENT SHALL ERICSSON BE LIABLE FOR INCIDENTAL OR CONSEQUENTIAL DAMAGES OF ANY NATURE WHATSOEVER, INCLUDING BUT NOT LIMITED TO LOST PROFITS OR COMMERCIAL LOSS. TO THE FULL EXTENT THOSE DAMAGES CAN BE DISCLAIMED BY LAW.**

Some countries do not allow the exclusion or limitation of incidental or consequential damage, or limitation of the duration of implied warranties, so the preceding limitations or exclusions may not apply to you. This warranty gives you specific legal rights, and you may also have other rights which may vary from country to country.

Declaration of Conformity

We, **Ericsson Mobile Communications AB** of
Nya Vattentornet
221 83 Lund, Sweden

declare under our sole responsibility that our product

Ericsson type **1100802-BV**

to which this declaration relates, conforms to the appropriate standards
TBR 19, TBR 20, TBR31, TBR32, ETS 300 342-1 and EN 60950,
following the provisions of Teleterminals directive **91/263/EEC**,
EMC directive **89/336/EEC**, and Low voltage directive **73/23/EEC**.

Stockholm
May 18, 1999

(Place & date of issue)

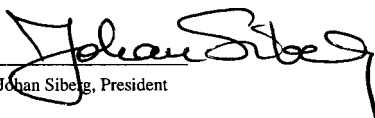

Johan Siberg, President

Index

A

- Alarm 86
- Alarm indicator 17
- Alert button 18, 21, 46, 92
 - turning on/off 47
- Alert calls 21, 92, 93
- Alert number 21
 - change number 47
- Alternate Line Service (ALS). See Two line service
- Answering calls 22
- Answering mode. See Handsfree calling
- Answering service. See Voice Mail
- Antenna
 - Switching antennas 10
- Area information 59
 - message types 60
 - receiving an area information message 61

B

- Banking by phone 35
- Barring calls. See Call barring
- Battery 7
 - attaching 8
 - charging 9
 - release catch 5
 - removing 10
- Battery charger 9, 99
 - Disconnecting the charger 9
- Battery meter 17
- Bell. See Alarm indicator
- Belt clip 11

C

- Calculator 86

- Call barring 67
 - activate 67
 - cancelling 67
 - change password 68
- Call cost 78
 - checking 78
 - setting a credit limit 79
 - specifying price per unit 79
- Call divert 62
 - activating 62
 - cancelling 63
 - checking status 63
 - divert indicator 17
- Call forwarding. See Call divert
- Call monitoring 95
- Call restrictions. See Call barring
- Call time 78
 - checking 78
- Call waiting 74
- Call waiting service 74
 - activating 74
 - cancelling 74
- Calling
 - from phone book 37
- Calling cards 83
 - storing numbers 84
- Calling Line Identification (CLI) 42
- Calling someone back 42

Calls 19
 alert 21, 92, 93
 answering 22
 during 24
 emergency 21, 93
 group calls. See group calls
 international 20
 making 19
 missed 42
 putting on hold 75
 receiving 22
 re-dialling 20
 reject 22
 switching between two calls 75
 unanswered 42
Card memory 33, 54
CB. See Area information
Cell broadcast. See Area information
Changing PIN 65
Changing PIN2 66
CLI. See Calling line identification
Clip
 swivel clip 11
Clock. See Time
Conference call
 adding new participants 76
 releasing a participants 77
Conference calls 76
 setting up 76
Credit cards 83
 storing numbers 84

D

Data calls 85
Date
 format 51
 setting 51
Desk/wall stand 99
Display 4
 greeting text 50
 indicators 17
 language 46
 light 50
 text 30
Divert indicator 17
Diverting calls. See Call divert
DTMF tones 25
During a call 24

E

Earpiece 4
 volume 24, 47, 91
Emergency calls 21, 93
Error messages 102

F

Fax, sending and receiving 85
Fixed dialling 68
 turn on/off 69
Fixed incoming calls 68
 turn on or off 69
Fixed incoming calls indicator 18
Fixed numbers
 editing 69
 storing 69
Forwarding calls. See Call divert

G

Greeting text in the display 50
Group calls 90
 call monitoring 95
 conversation limit 96
 during 95
 making 92
 receiving 94
 re-entry 95
GSM Pro 90
 call monitoring 95
 group calls 90
 push-to-talk mode 90
 wireless dispatch console 96

H

Handsfree calling 98
 answering mode 98
Hiding your phone number 22

I

Icons in display. See Indicators in display
Indicator light 4

Indicators in display 17
alarm 17
battery meter 17
flexed incoming calls 18
keypad lock 17
line 18
signal strength 17
silent ring 17
SMS 17
voice mail 17

Instructions in the manual 31
International calls 20

K

Key functions 18
Key sound 49
Keypad 4
Keypad lock
lock 64
unlock 64
Keypad lock indicator 17

L

Language in display 46
Letters, entering 34
Line indicator 18
Lock keypad 64

M

Manual
instructions 31
Menu system 30
Message signal 49
Microphone 4
muting 24
Minute 49
Minute minder 49
Missed calls 42
Mode switch 18, 26
Switching modes 26
switching modes 91
Muting microphone 24

N

Name recall 37

Network 14, 70
no network 15
search modes 70
searching 14
selecting 71

Networks
forbidden 72
preferred 72

P

Phone book 33, 92
banking by phone 35
calling from 37
card memory 33
changing a name 39
changing a number 39
copying 39
entering letters 34
erasing a phone number 36
keeping up to date 38
name recall 37
overwrite protection 36
phone memory 33
position recall 38
storing names 35
storing numbers 35
using the push-to-talk button 37

Phone lock 66

autolock 66
change security code 66
full Lock 66
lock 67
unlock 67

Phone memory 33, 53

Phone number
displaying own 50
hiding 22
showing 22

Phone Number in SMS 58

PIN 7, 14
change code 65

PIN2 7
change code 66

Plus sign (+) 18

Position recall 38

Preferred networks 72

PUK 7

Push-to-talk button *18*
 answering *90*
 calling *37, 90*
 speaking *90*

Push-to-talk mode *90*

Put a call on hold *75*

Q

Quick dialling. See Speed dialling

Quick keys

R

Reading text messages (SMS) *56*

Receive Calls *22*

Receiving text messages (SMS) *56*

Re-dialling *20*

 Automatic Re-dialling *20*

Rejecting calls *22*

Reply Requested Reply *57*

Request reply *55*

Resetting phone *51*

Restricting calls. See Call barring

Ring signal

 choosing *48*

 composing own *49*

 level *16, 48*

 type *48*

S

Scratch pad *24*

Scroll *18*

Sending text messages (SMS) *55*

Shortcuts. See Quick keys

Showing your phone number *22*

Signal strength meter *17*

Silent ring signal *17*

SIM Card

 unblocking *65*

SIM card *6*

 change PIN code *65*

 change PIN2 code *66*

 inserting *6*

 lock *66*

 unlock *66*

SMS *53*

 card memory *54*

 composing a text message *54*

 enable the phone to send SMS *54*

 erasing *57*

 message types *56*

 phone memory *53*

 phone number in SMS *58*

 reading *56*

 receiving *56*

 reply requested reply *57*

 replying *57*

 request reply *55*

 sending *55*

 sending a text message *55*

 storing *58*

 validity period *56*

SMS indicator *17*

Speakerphone *26*

 switching modes *26*

 turn on *26*

Speed dialling *38*

Stored messages (SMS)

 reading *59*

Storing

 names *35*

 numbers *35*

Switching between two calls *75*

Switching modes *26, 91*

T

Tape loops. See Voice mail indicator

Text messages. See SMS

Time *15, 51*

 format

 setting

Tone signals *25*

Touch tones *25*

Turning the phone off *16*

Turning the phone on *14*

Two line service *81*

 changing names *82*

 selecting a line *81*

 settings *81*

U

Unanswered calls *42*

Unlock keypad *64*

V

Vibrating Call Alert

turn on/off 48

Voice mail 44

activating 44

calling 44

Voice mail indicator 17

Volume

earpiece 24, 91

ring signal 48

Volume keys 4, 18

Not for Commercial Use
Ericsson Mobile Communications AB