

The logo for N-GAGE QD. The 'N' is red, 'GAGE' is white, and 'QD' is orange. The background features a dark grey grid pattern that recedes into the distance, creating a tunnel effect. A horizontal line with orange and yellow segments runs across the middle of the page.

N·GAGE QD

USER'S GUIDE

NOKIA



DECLARATION OF CONFORMITY We, NOKIA CORPORATION declare under our sole responsibility that the product RH-29 is in conformity with the provisions of the following Council Directive: 1999/5/EC. A copy of the Declaration of Conformity can be found at http://www.nokia.com/phones/declaration_of_conformity/

Copyright © 2004 Nokia. All rights reserved.

Reproduction, transfer, distribution or storage of part or all of the contents in this document in any form without the prior written permission of Nokia is prohibited. Nokia, Nokia Connecting People, N-Gage, and N-Gage QD are trademarks or registered trademarks of Nokia Corporation. Other product and company names mentioned herein may be trademarks or tradenames of their respective owners. Nokia tune is a sound mark of Nokia Corporation.

symbian

This product includes software licensed from Symbian Ltd © 1998-2004. Symbian and Symbian OS are trademarks of Symbian Ltd.



Java™ and all Java-based marks are trademarks or registered trademarks of Sun Microsystems, Inc.

Bluetooth is a registered trademark of Bluetooth SIG, Inc.

Stac®, LZS®, ©1996, Stac, Inc., ©1994-1996 Microsoft Corporation. Includes one or more U.S. Patents: No. 4701745, 5016009, 5126739, 5146221, and 5414425. Other patents pending.

Hi/fn®, LZS®, ©1988-98, Hi/fn. Includes one or more U.S. Patents: No. 4701745, 5016009, 5126739, 5146221, and 5414425. Other patents pending.

Part of the software in this product is © Copyright ANT Ltd. 1998. All rights reserved.

m-Router Connectivity Components © 2000-2002 Intuwave Limited. All rights reserved. (www.intuwave.com)

US Patent No 5818437 and other pending patents. T9 text input software Copyright (C) 1997-2004. Tegic Communications, Inc. All rights reserved.

Nokia operates a policy of continuous development. Nokia reserves the right to make changes and improvements to any of the products described in this document without prior notice.

Under no circumstances shall Nokia be responsible for any loss of data or income or any special, incidental, consequential or indirect damages howsoever caused.

The contents of this document are provided 'as is'. Except as required by applicable law, no warranties of any kind, either express or implied, including, but not limited to, the implied warranties of merchantability and fitness for a particular purpose, are made in relation to the accuracy, reliability or contents of this document. Nokia reserves the right to revise this document or withdraw it at any time without prior notice

The availability of particular products may vary by region. Please check with the Nokia dealer nearest to you.

9311149

ISSUE 1 EN

Contents

FOR YOUR SAFETY	7	Your game deck	20
Getting started	9	Personalising your game deck.....	20
Installing the SIM card and the battery.....	9	Shortcuts in standby mode.....	20
Charging the battery.....	11	Essential indicators in standby mode.....	21
Switching the game deck on.....	11	Memory management.....	22
Keys and parts.....	12	Viewing memory consumption.....	22
About the display.....	12	Freeing memory.....	23
Keypad lock.....	13	Memory card tool.....	23
Inserting a game or memory card.....	13	Formatting a memory card.....	24
Ejecting a memory card.....	14	Backing up and restoring information on a memory card.....	24
Playing a game.....	15	Locking the memory card.....	24
Saving power when playing.....	15	Volume control.....	25
Starting a multi-player game.....	15	Telephone	26
Game manager - Managing game data.....	15	Making a call.....	26
Backing up and restoring game data.....	16	Speed dialling a phone number.....	27
The N-Gage Arena launcher.....	16	Making a conference call (Network Service).....	27
Before using the N-Gage Arena launcher.....	17	Answering or rejecting a call.....	27
Connecting to N-Gage Arena.....	17	Call waiting (Network Service).....	28
Registration and login.....	17	Options during a call.....	28
Updating the N-Gage Arena launcher.....	18	Diverting calls (Network Service).....	29
Help.....	18	Log - Call register and general log.....	29
Tips for efficient use.....	18	Recent calls register.....	29

Call duration	30
Call costs (Network Service).....	30
GPRS counter.....	31
Viewing the general log.....	31
Log settings.....	32
SIM directory and other SIM services	32
Settings	33
Changing settings	33
Device settings.....	33
General	33
Standby mode.....	34
Display	34
Call settings.....	34
Connection settings.....	36
About data connections and access points.....	36
Creating an access point	37
Access points	37
GPRS.....	39
Data call	40
Date and time.....	40
Security	41
Device and SIM	41
Certif. management.....	42
Call barring (Network Service)	44
Network.....	45
Enhancement settings - Headset and loopset.....	45

Contacts (Phonebook).....	46
Saving names and numbers - Creating and editing contact cards.....	46
Copying contacts between the SIM card and device memory	47
Adding a ringing tone for a contact card or group...	47
Voice dialling.....	47
Adding a voice tag to a phone number	48
Making a call by saying a voice tag.....	48
Creating contact groups	49
Removing members from a group	49
Imaging.....	50
Images - Viewing images	50
Screen shot.....	50
Changing Screen shot settings.....	51
Video player.....	51
Receiving a video clip in a message	52
Messaging	53
Writing text	54
Traditional text input.....	54
Predictive text input - Dictionary.....	55
Copying text to clipboard	56
Writing and sending messages	57
Settings needed for multimedia messaging	58
Settings needed for e-mail.....	59
Inbox - receiving messages.....	59

Receiving multimedia objects.....	59	Calendar views.....	74
Receiving logos, tones, business cards, calendar entries, and settings.....	60	To-do - Task list.....	74
Receiving service messages.....	61	Extras	75
My folders	61	Calculator.....	75
Mailbox.....	61	Composer.....	75
Opening the mailbox.....	61	Converter - Converting measures.....	76
Retrieving e-mail messages from the mailbox....	62	Setting a base currency and exchange rates.....	77
Deleting e-mail messages.....	63	Notes.....	77
Disconnecting from the mailbox.....	63	Clock.....	78
Outbox - Messages waiting to be sent.....	64	Setting an alarm.....	78
Viewing messages on a SIM card.....	64	Recorder.....	78
Cell broadcast (Network Service).....	64	Go to.....	79
Service command editor.....	65	Adding shortcuts.....	79
Messaging settings.....	65	Web	80
Settings for text messages.....	65	Basic steps for accessing Web.....	80
Settings for multimedia messages.....	66	Receiving settings in a text message.....	80
Settings for e-mail.....	68	Keying in the settings manually.....	80
Settings for service messages.....	69	Bookmarks view.....	81
Settings for Cell broadcast (Network Service)....	69	Making a connection.....	81
Settings for the Other folder.....	70	Connection security.....	81
Profiles	71	Browsing.....	82
Changing the profile.....	71	Ending a connection.....	82
Customising profiles.....	72	Emptying the cache.....	83
Calendar and To-do	73	Settings for Web.....	83
Creating calendar entries.....	73	Applications and Manager	84

Notes on installing applications and software.....	84	Pairing devices	90
Applications (Java™)	85	Receiving data via Bluetooth.....	91
Installing an application.....	85	Switching off Bluetooth.....	91
Applications main view.....	85	Connecting to a computer via Bluetooth	91
Applications settings.....	86	Using the CD-ROM	91
Manager - Installing and removing software	86	Battery information	92
Installing software	86	Charging and Discharging	92
Removing software	87	CARE AND MAINTENANCE	92
Connectivity	88	ADDITIONAL SAFETY INFORMATION	93
Bluetooth connection	88	Index	97
Bluetooth settings.....	89		
Sending data via Bluetooth.....	89		

FOR YOUR SAFETY

Read these simple guidelines. Not following them may be dangerous or illegal. Read the complete user guide for further information.



SWITCH ON SAFELY Do not switch the device on when wireless phone use is prohibited or when it may cause interference or danger.



ROAD SAFETY COMES FIRST Obey all local laws. Always keep your hands free to operate the vehicle while driving. Your first consideration while driving should be road safety.



INTERFERENCE All wireless devices may be susceptible to interference, which could affect performance.



SWITCH OFF IN HOSPITALS Follow any restrictions. Switch the device off near medical equipment.



SWITCH OFF IN AIRCRAFT Follow any restrictions. Wireless devices can cause interference in aircraft.



SWITCH OFF WHEN REFUELLING Don't use the device at a refuelling point. Don't use near fuel or chemicals.



SWITCH OFF NEAR BLASTING Follow any restrictions. Don't use the device where blasting is in progress.



USE SENSIBLY Use only in the normal position as explained in the product documentation. Don't touch the antenna unnecessarily.



QUALIFIED SERVICE Only qualified personnel may install or repair this product.



ENHANCEMENTS AND BATTERIES Use only approved enhancements and batteries. Do not connect incompatible products.



WATER-RESISTANCE Your device is not water-resistant. Keep it dry.





BACK-UP COPIES Remember to make back-up copies or keep a written record of all important information.



CONNECTING TO OTHER DEVICES When connecting to any other device, read its user guide for detailed safety instructions. Do not connect incompatible products.



EMERGENCY CALLS Ensure the phone function of the device is switched on and in service. Press  as many times as needed to clear the display and return to the start screen. Key in the emergency number, then press . Give your location. Do not end the call until given permission to do so.

ABOUT YOUR DEVICE

The wireless device described in this guide is approved for use on the EGSM 900 and GSM 1800 network. Contact your service provider for more information about networks.

When using the features in this device, obey all laws and respect privacy and legitimate rights of others.



Warning: To use any features in this device, other than the alarm clock, the device must be switched on. Do not switch the device on when wireless phone use may cause interference or danger.

Network Services

To use the phone you must have service from a wireless service provider. Many of the features in this device depend on features in the wireless network to function. These Network Services may not be available on all networks or you may have to make specific arrangements with your service provider before you can utilize Network

Services. Your service provider may need to give you additional instructions for their use and explain what charges will apply. Some networks may have limitations that affect how you can use Network Services. For instance, some networks may not support all language-dependent characters and services.

Your service provider may have requested that certain features be disabled or not activated in your device. If so, they will not appear on your device menu. Contact your service provider for more information.

Enhancements, batteries, and chargers

Check the model number of any charger before use with this device. This device is intended for use when supplied with power from ACP-12 and LCH-12.



Warning: Use only batteries, chargers, and enhancements approved by Nokia for use with this particular model. The use of any other types may invalidate any approval or warranty, and may be dangerous.

For availability of approved enhancements, please check with your dealer. When you disconnect the power cord of any enhancement, grasp and pull the plug, not the cord.

Your device and its enhancements may contain small parts. Keep them out of reach of small children.

Getting started

Installing the SIM card and the battery



Note: Before removing the cover, always switch off the power and disconnect the charger and any other device. Always store and use the device with the covers attached.

Keep all SIM cards out of the reach of small children. For availability and information on using SIM card services, contact your SIM card vendor. This may be the service provider, network operator, or other vendor.

- 1 With the back of the game deck facing you, press the release button (1) and slide the cover in the direction of the arrow.

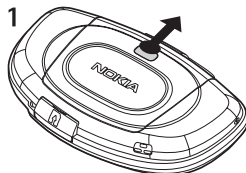

- 2 To release the SIM card holder, slide the holder in the direction of the arrow (2) and open it (3).

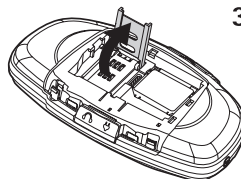
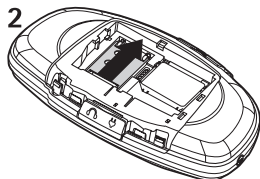

- 3 Insert the SIM card into the holder (4). Make sure that the bevelled corner on the SIM card is facing upward from the holder and that the golden contact area on the card is facing the connectors on the device.

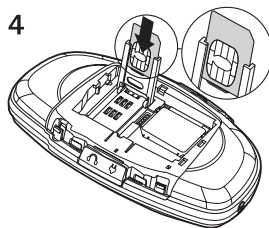

- 4 Close the SIM card holder (5) and lock it into place (6).

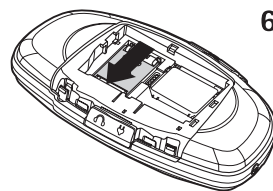
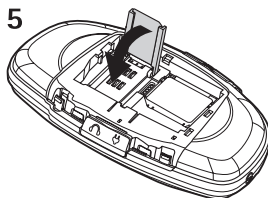

- 5 Insert the battery (7).

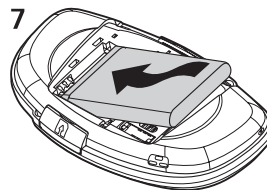

- 6 Replace the back cover.

Charging the battery

- 1 Open the latch marked with . Connect the power cord to the game deck (8).
- 2 Connect the charger to an AC wall outlet. The battery indicator bar starts scrolling. The game deck can be used while charging. If the battery is totally run down, it may take a few minutes before the charging indicator is shown.
- 3 When the battery is fully charged, the bar stops scrolling. Disconnect the charger, first from the game deck and then from the AC outlet.

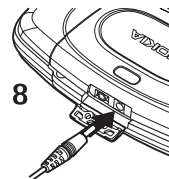

Switching the game deck on

- Press and hold the power key  (9).

If the game deck requests a PIN code, key in the code (displayed as ****) and press  OK. The PIN code is usually supplied with the SIM card.

If the game deck requests a lock code, key in the lock code (displayed as ****) and press  OK. The factory setting for the lock code is **12345**. See 'Device and SIM', p. 41.



Your device has a built-in antenna. **Note:** As with any other radio transmitting device, do not touch the antenna unnecessarily when the device is switched on. Contact with the antenna affects call quality and may cause the device to operate at a higher power level than otherwise needed. Avoiding contact with the antenna area when operating the device optimises the antenna performance and the battery life.

NORMAL POSITION: Hold the device with the antenna pointed up and over your shoulder.

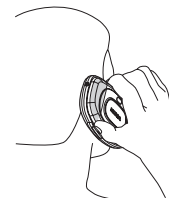
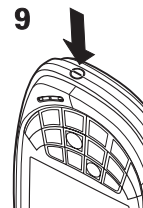

Keys and parts

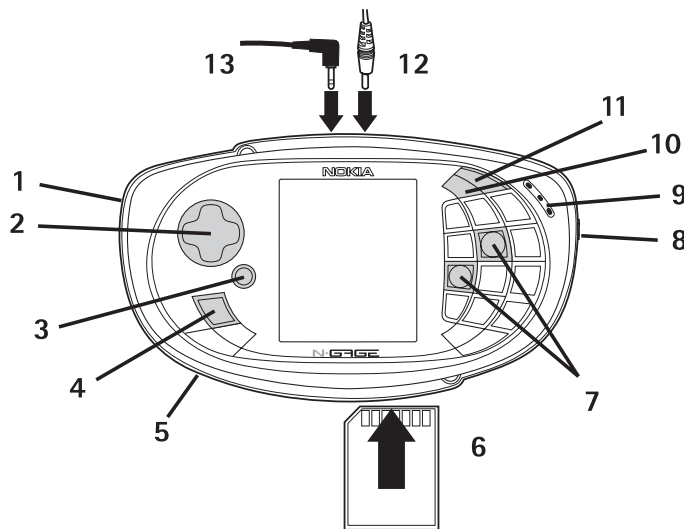

- 1 Microphone is at the side.
- 2 Controller key for playing games and moving around.
- 3 OK key selects, accepts, or activates.
- 4 Menu key opens the main Menu.
- 5 Loudspeaker is at the back.
- 6 Slot for memory or game cards.
- 7 and are the game keys.
- 8 Power key is at the side.
- 9 Earpiece.
- 10 Edit key opens a list of commands when you are editing text such as **Copy**, **Cut**, and **Paste**.
- 11 Clear key for deleting text and items.
- 12 Charger connector.
- 13 Headset connector.

Warning: When using a headset your ability to hear outside sounds may be affected. Do not use a headset in situations where it can endanger your safety.





About the display

A small number of missing, discoloured, or bright dots may appear on the screen. This is a characteristic of this type of

display. Some displays may contain pixels or dots that remain on or off. This is normal, not a fault.



Keypad lock

Use the keypad lock to prevent the keys from being accidentally pressed.

- **To lock:** In standby mode press  and . When the keys are locked,  appears on the display.
- **To unlock:** Press  and .

If you have allowed games to start automatically and insert a game card in the game deck, the keypad lock unlocks automatically.

When the keypad lock is on, calls still may be possible to the official emergency number programmed into your device. Key in the emergency number and press .

 **Tip!** Press  once, select **Lock keypad** and press **OK**.

Inserting a game or memory card

Keep all game and memory cards out of the reach of small children.

Use only compatible Multimedia cards (MMC) with this device. Other memory cards, such as Secure Digital (SD) cards, do not fit in the MMC card slot and are not compatible with this device. Using an incompatible memory card may damage the memory card as well as the device, and data stored on the incompatible card may be corrupted.

You can purchase a variety of N-Gage games for your game deck. Each N-Gage game is supplied on a separate read-only game card (MMC). The game data, such as high scores, is saved to the game deck's memory, not on the N-Gage game card. For availability of different games contact a games supplier approved by Nokia or visit www.n-gage.com.

You can buy compatible flash memory cards (MMC) to get extra storage space. See 'Memory card tool', p. 23.

- 1 Open the card slot (1).
- 2 Insert a game or a memory card (2). Note that inserting a game or a memory card closes all applications that are open in the device.
- 3 Close the card slot.

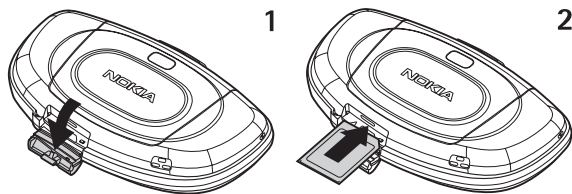



If you inserted a game card, the game starts automatically. Also, the game icon is automatically added as the last item of the main Menu. Information stored on a memory card is indicated with  in different applications.

Ejecting a memory card



Important: Do not remove the card in the middle of an operation when  is blinking in the top right corner of the display. Removing the card in the middle of an operation may damage the memory card as well as the device, and data stored on the card may be corrupted.

- 1 Press  and select **Remove mem. card** (available only if a memory card is inserted).
- 2 Wait until the *Memory card can be removed now* text appears and remove the card.

 **Tip!** Visit www.n-gage.com for more information on available games and to get game service settings.

Playing a game

Insert a game card, see 'Inserting a game or memory card', p. 13. The game starts automatically, which also unlocks the keypad lock.



Note: Exit a game before removing a game card from the game deck.

You can use the primary game keys and for playing games. Other keys may be used depending on the game. Follow the instructions supplied with the game.



Note: Playing games consumes power and the game deck's operating time is reduced.



Tip! To start a game when a game card is inserted, press in standby mode.

Saving power when playing

- To reduce display brightness, press and go to **Tools**→**Settings**→**Device**→**Display**→**Brightness**. Select **Options**→**Change**.
- Use the headset to listen to the game tones while playing.
- Switch off Bluetooth when you are not using it.

Starting a multi-player game

You can play some games with two or more players who have the same game on a compatible device. Playing is done via Bluetooth connection. Before starting a multi-player game, ensure that the Bluetooth settings of the devices are compatible. See 'Bluetooth connection', p. 88. Refer to the instructions supplied with the game for details of how to start the game, different levels, additional features, etc.



Game manager - Managing game data

Press and select **Tools**→**Game mgr.** to view and manage game-related files. You can delete files that you no longer need to free memory and back up and restore files to and from a memory card.

Options in the Game manager main view: **File details**, **Delete**, **Send**, **Backup**, **Restore from card**, **Mark/Unmark**, **Settings**, **Help**, and **Exit**.



Game file types:

Game data - Files required to play a game, such as game sounds.

Game extensions -

Optional game files, such as extra levels.

User data - Files saved when playing, such as high scores and checkpoints you have reached.

- To view game data file details such as the file type and size, scroll to the desired file and select **Options**→ **File details**, or press  and  to scroll through the details.
- To delete a file, scroll to the file and select **Options**→ **Delete**.
- To change the appearance of Game manager and to choose how files are grouped and sorted, press **Options**→ **Settings**.

Backing up and restoring game data

- To back up game data from your game deck's memory to a memory card, scroll to the file that you want to back up and select **Options**→ **Backup**.
- To restore game data from the memory card to the game deck's memory, select **Options**→ **Restore from card**. Scroll to the file that you want to restore and select **Options**→ **Restore**.



Tip! You can back up game files, such as your high scores, to a memory card and then use the restore function to copy the files to another compatible device.

Copyright protections may prevent some images, ringing tones, and other content from being copied, modified, transferred, or forwarded.

Protected files are marked as **Not portable** in the file details and cannot be used on other devices. **Portable** files may be used on other compatible devices.



The N-Gage Arena launcher

The N-Gage Arena launcher is an application that gives you access to the N-Gage Arena community directly from your game deck. Members of the N-Gage Arena community can communicate with each other, download exclusive content, access global rankings, join tournaments, get game and community news, and more.





Tip! For more information on the N-Gage Arena, including games, activities, and support, visit <http://arena.n-gage.com>.

Before using the N-Gage Arena launcher

To use the N-Gage Arena launcher you must subscribe to a GPRS service. For availability and subscription to a GPRS service, contact your network operator or service provider. Note that GPRS connections and transmissions may be subject to separate fees.

You also need an Internet access point (IAP) defined in your game deck. You may receive Internet access point settings in a special text message from your network operator or service provider, or you can key in the settings manually. Your game deck may also have Internet access points preset by your service provider.

If there are no predefined Internet access points in your game deck, you can order Internet access point settings, as well as other settings, from the N-Gage website at <http://support.n-gage.com/>. Choose your country, if available, and use the settings configurator tool to order the Internet settings for your network operator. The settings will be sent to your game deck as a text message.

 **Tip!** To check your access points or to define settings for an access point, press  and select **Tools**→**Settings**→**Connection**→**Access points**.

Connecting to the N-Gage Arena

There are three ways to access the N-Gage Arena:

- Use the N-Gage Arena launcher in your game deck. Press  and select **Arena**.
- With a compatible PC. Go to the N-Gage Arena website at <http://arena.n-gage.com>.
- While playing an N-Gage Arena game. Select **N-Gage Arena** from the game menu.

The N-Gage Arena launcher and the website provide access to all features and activities available on the N-Gage Arena. The in-game menus provide access to features and content specific to the game you are playing.

Registration and login

To use the features and participate the activities of the N-Gage Arena, you are required to register as a member of the N-Gage Arena community. You can register and create a login account either with a PC on the website, or with your game deck using the N-Gage Arena

launcher. During registration you will be asked to choose a username and password. Once you have registered as a member, you can log into the N-Gage Arena with your username and password.

Updating the N-Gage Arena launcher

Updates for the N-Gage Arena launcher will be released regularly. Every time you connect to the N-Gage Arena with your game deck, the application checks if updates are available. If an update is found you will be asked whether you want to download it or not. Some of the updates for the N-Gage Arena launcher are required and some are optional.



Note: If you do not accept the download of a required update, you will no longer be able to use the N-Gage Arena launcher.



Help

Your game deck has a help function that you can access from any application by selecting **Options**→**Help**.





Example: To view instructions on how to create a contact card: start to create a contact card and select **Options**→**Help**. When you are reading the instructions, you can switch between Help and the application that is open in the background by pressing and holding . You can access the same Help topic when you press  and go to **Help**→**Contacts**→**Creating contact cards**.











Fig. 1 Help in the device.

Tips for efficient use

- To switch between applications that are open, press and hold . See Fig. 2.



Note: If memory is getting low, the game deck may close some applications. The game deck saves any unsaved data before an application is closed.

- **To mark an item**, scroll to it and press  and  at the same time.
- **To mark multiple items**, press and hold  and at the same time press  or . A check mark is placed next to the selected items. To end the selection, stop the scrolling with  and then release . Once you have selected all the items you want, you can move or delete them.
- In some situations, when you press , a shorter options list appears showing the main commands available in the view.

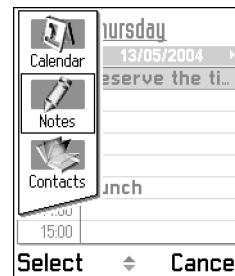

Fig. 2 Switching between applications.

Your game deck

Personalising your game deck







- To change the image shown as the standby mode background, go to **Tools**→**Settings**→**Device**→**Standby mode**→**Wallpaper** and select **Yes**. See Fig. 3.
- To change the colour scheme in your game deck, go to **Tools**→**Settings**→**Device**→**Display**→**Colour palette**.
- To change shortcuts assigned for the selection keys in standby mode, go to **Tools**→**Settings**→**Device**→**Standby mode**→**Left selection key** or **Right selection key**. See Fig. 3.
- To change the clock shown in standby mode, go to **Tools**→**Settings**→**Date and time settings**→**Clock type**→**Analogue** or **Digital**.
- To change the welcome note, image, or animation, go to **Tools**→**Settings**→**Device**→**General**→**Welcome note or logo**.
- To change what is shown in the screen saver, go to **Tools**→**Settings**→**Device**→**Display**→**Screen saver**.
- To change the ringing tones and keypad tones, go to **Tools**→**Profiles**. If the selected profile is **General**, the current date is displayed instead of the profile name in the navigation bar. See 'Profiles', p. 71.
- To assign an individual ringing tone to a friend, go to **Contacts**. See p. 47.
- To rearrange the main Menu, in the main Menu, select **Options**→**Move, New folder**, or **Move to folder**. You can move more rarely used applications into folders and place applications that you use more often into the main Menu.



Fig. 3 Standby mode.

Shortcuts in standby mode

- To switch between applications that are open, press and hold .

- To change the profile, press  and select a profile.
- To lock the keypad, press  and .
- To start a game when a game card is inserted, press .
- To open the last dialled numbers list, press .
- To start a connection to Web, press and hold . See 'Basic steps for accessing Web', p. 84.

Essential indicators in standby mode

 - You have received one or several messages to the Inbox folder in Messaging.

 - You have received one or several voice messages. See 'Calling your voice mailbox (Network Service)', p. 26.

 - There are messages waiting to be sent in Outbox. See p. 64.

 - Shown if **Incoming call alert** is set to **Silent** and **Message alert tone to Off**. See 'Profiles', p. 71.



 - The game deck's keypad is locked. See 'Keypad lock', p. 13.



 - You have an active alarm. See 'Clock', p. 78.

 - You can make calls using phone line 2 only (Network Service).

 - All calls to the game deck are diverted to another number. If you have two phone lines, the divert indicator for the first line is 1 and for the second line 2. See 'Line in use (Network Service)', p. 35.

 - A memory card is being read or written to.



 or  - A headset or loopset is connected to the device.

 - A data call is active.  - A high speed data call is active.

 - Shown instead of the signal strength indicator (shown in the top left corner in standby mode) when there is an active GPRS connection. See 'GPRS', p. 39.

 - Shown when the GPRS connection is on hold, for example, during voice calls.

F - A fax call is active.

 - Bluetooth is active. Note that, when data is transmitted via Bluetooth,  is shown. See 'Bluetooth connection', p. 88.

Memory management

Many features of the game deck use memory to store data. These features include games, contacts, messages, images and ringing tones, calendar and to-do notes, documents, and downloaded applications. The free memory available depends on how much data is already saved in the game deck memory.

You can use a memory card as extra storage space. Memory cards are re-writable, so you can delete and save data on a memory card. If the game deck memory is getting low, you can move different files to a memory card.

 **Note:** You cannot save any data on a game card as they are read-only. Game cards contain data that cannot be overwritten.

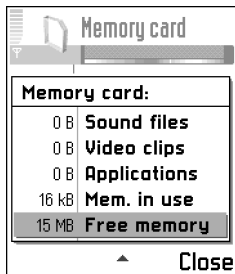

Fig. 4 Memory consumption of the memory card.

Viewing memory consumption

To view what kind of data you have in the game deck and how much memory the different data groups consume, go to **Tools**→ **Manager** and select **Options**→ **Device memory**. Scroll down to **Free memory** to view the amount of free memory in the game deck.

If you have a memory card inserted in the game deck, go to **Tools**→ **Memory** and select **Options**→ **Memory details** to view the memory consumption and the amount of free memory on the card.

Freeing memory

Installing a lot of games or saving many images can use a large amount of the available memory, and the game deck notifies you that memory is getting low. To free memory, transfer some of the games, images or other entries to a memory card. You can also delete items such as contact information, calendar notes, call timers, call cost timers, game scores, or any other data that you no longer need. Go to the respective application to remove the data.

Other items that you can delete to free memory:

- Installed games that are no longer required.
- Messages from the Inbox, Drafts, and Sent folders in Messaging.
- Retrieved e-mail messages from the game deck memory.
- Saved XHTML or WML pages, and images in Images.



Memory card tool

Press  and select **Tools**→**Memory**. You can use a memory card to store your downloaded games and applications, for example. You can also back up information from your game deck's memory and restore the information to the game deck later. See 'Inserting a game or memory card', p. 13 and 'Ejecting a memory card', p. 14.

Keep all memory cards out of the reach of small children.



Important: Do not remove the card in the middle of an operation when  is blinking in the top right corner of the display. Removing the card in the middle of an operation may damage the memory card as well as the device, and data stored on the card may be corrupted.

Use only compatible Multimedia cards (MMC) with this device. Other memory cards, such as Secure Digital (SD) cards, do not fit in the MMC card slot and are not compatible with

Options in Memory card:
Backup device mem.,
Restore from card,
Format mem. card,
Memory card name, Set
password, Change
password, Remove
password, Unlock
memory card, Memory
details, Help, and Exit.

 **Tip!** To rename a memory card, go to **Memory card** and select **Options**→**Memory card name**.

this device. Using an incompatible memory card may damage the memory card as well as the device, and data stored on the incompatible card may be corrupted.

Formatting a memory card



Important: When a memory card is formatted, all data on the card is permanently lost.

Some memory cards are supplied pre-formatted and others require formatting. Consult your retailer to find out if you must format the memory card before you can use it.

- Select **Options**→**Format mem. card**. Select **Yes** to confirm. When formatting is complete, key in a name for the memory card and press **OK**.

Backing up and restoring information on a memory card

- To backup information from your game deck's memory to a memory card, select **Options**→**Backup device mem..**
- To restore information from the memory card to the game deck's memory, select **Options**→**Restore from card**.

Locking the memory card

You can set a password to protect your memory card against unauthorised use.

The password is stored in your game deck and you do not have to enter it again while you are using the memory card on the same game deck. If you want to use the memory card on another game deck, you will be asked for the password.

- Select **Options**→**Set password, Change password, or Remove password**. For every option you will be asked to enter and confirm your password (max. 8 characters).





Note: Once the password is removed, the memory card is unlocked and can be used on another game deck without a password.

Unlocking a memory card

If you insert another password-protected memory card in your game deck, you will be prompted to enter the password of the card.

- To unlock the card, select **Options**→ **Unlock memory card**.

Volume control

When you have an active call or are listening to a tone, press  or  to increase or decrease the volume level, respectively.

The loudspeaker allows you to speak and listen to the game deck from a short distance without having to hold the game deck to your ear, for example, having it on a table nearby. To locate the loudspeaker, see 'Keys and parts', p.12.

To start using the loudspeaker during an already active call, select **Options→ **Activate loudsp.**** Sound applications such as Composer and Recorder use the loudspeaker by default.



Important: Do not hold the game deck near your ear when the loudspeaker is in use, because the volume may be extremely loud.

To turn off the loudspeaker, when you have an active call or music is playing, select **Options→ **Activate handset**.**

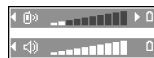











Fig. 5 Navigation bar shows the speaker in use.



Telephone



 **Tip!** To adjust the volume during a call, press  to increase and  to decrease the volume level.

 **Tip!** To change the phone number of your voice mailbox, press  and select **Tools**→**Voice mailbox** and select **Options**→**Change number**. Key in the number (obtained from your service provider) and press **OK**.



Making a call

- 1 In standby mode, key in the phone number, including the area code. Press  to remove a number. For international calls, press  twice for the international prefix (the + character replaces the international access code) and then key in the country code, the area code without 0, and the phone number.
- 2 Press  to call the number.
- 3 Press  to end the call (or to cancel the call attempt).

 **Note:** Pressing  will always end a call, even if another application is active.

 **Tip!** In standby mode, press  to access a list of the 20 last numbers you called or attempted to call. Scroll to the number you want and press  to call the number.





Making a call using Contacts

- Press  and select **Contacts**. Scroll to the desired name. Or, key in the first letters of the name to the Search field. Matching contacts are listed. Press  to call.

Calling your voice mailbox (Network Service)

- To call your voice mailbox, press and hold  in standby mode. If the game deck asks for the voice mailbox number (obtained from your service provider), key it in and press **OK**. See also 'Diverting calls (Network Service)', p. 29. Each phone line may have its own voice mailbox number, see 'Line in use (Network Service)', p. 35.

Speed dialling a phone number

- 1 Press  and select **Tools**→ **Speed dial** and assign a phone number to one of the speed dialling keys ( - ).  is reserved for the voice mailbox.
- 2 Go to **Tools**→ **Settings**→ **Call settings** and set **Speed dialling** to **On**.
- 3 To call: In standby mode, press and hold the speed dialling key until the call is started.

Making a conference call (Network Service)

- 1 Make a call to the first participant.
- 2 Make a call to another participant, select **Options**→ **New call**. Key in or search for the phone number and press **OK**. The first call is automatically put on hold.
- 3 When the new call has been answered, join the first participant in the conference call. Select **Options**→ **Conference**.
 - To add a new person to the call, repeat step 2 and then select **Options**→ **Conference**→ **Add to conference**. The device supports conference calls between a maximum of six participants, including yourself.
 - To have a private conversation with one of the participants: Select **Options**→ **Conference**→ **Private**. Scroll to the desired participant and press **Private**. The conference call is put on hold on your game deck. The other participants can still continue the conference call. Once you have finished the private conversation, select **Options**→ **Add to conference** to return to the conference call.
 - To drop a participant, select **Options**→ **Conference**→ **Drop participant**, then scroll to the participant and press **Drop**.
- 4 To end the active conference call, press .

Answering or rejecting a call



- To answer an incoming call, press  and press  to end the call.
- If you do not want to answer a call, press . The caller will hear a "line busy" tone.



Fig. 6 A conference call with two participants.

If a compatible headset is connected to the device, you can answer and end a call by pressing the headset key.

If you press **Silence**, only the ringing tone is muted. Then either answer or reject the call.





Tip! If you have activated the **Call divert**→ **If busy** function to divert calls, for example, to your voice mailbox, rejecting an incoming call will also divert the call. See 'Diverting calls (Network Service)', p. 29.

Call waiting (Network Service)

If you have activated the Call waiting service, the network will notify you of a new incoming call while you have a call in progress. To change the settings, Press  and select **Tools**→ **Settings**→ **Call settings**→ **Call waiting**: See also p. 35.



Tip! To adjust the game deck tones for different environments and events, for example, when you want your game deck to be silent, see 'Profiles', p. 71.

- 1 During a call, press  to answer the waiting call. The first call is put on hold. To switch between the two calls, press **Swap**.
- 2 To end the active call, press .



Options during a call

Many of the options that you can use during a call are network services. Press **Options** during a call for some of the following options: **Mute** or **Unmute**, **End active call**, **End all calls**, **Hold** or **Unhold**, **New call**, **Conference**, **Private**, **Drop participant**, **Answer**, and **Reject**.



Tip! You can add DTMF tones to the **Phone number** or **DTMF** fields in a contact card.

Swap to switch between an active call and a call on hold, **Transfer** to connect an incoming call or a call on hold with an active call and to disconnect yourself from the calls.

Send DTMF to send DTMF tone strings, for example, passwords or bank account numbers. Key in the DTMF string or search for it in Contacts. Press  repeatedly to produce: *****, **p** (pause), or **w** (wait). Press  to produce **#**. Press **OK** to send the tone.

Diverting calls (Network Service)

- 1 To direct your incoming calls to another number, Press  and select **Tools**→ **Call divert**. For details, contact your service provider.
- 2 Select one of the divert options, for example, select **If busy** to divert voice calls when your number is busy or when you reject incoming calls.
- 3 Select **Options**→ **Activate** to set the divert setting on, **Cancel** to set the divert setting off, **Check status** to check whether the divert is activated or not, or **Cancel all divers** to cancel all active divers. See 'Essential indicators in standby mode', p. 21.



Note: You cannot have barring of incoming calls and call diverting active at the same time. See 'Call barring (Network Service)', p. 44.





Log – Call register and general log

To monitor phone calls, text messages, or data connections registered by the game deck, press  and select **Tools**→ **Log** and press . You can filter the general log to view just one type of event and create new contact cards based on the log information.

Connections to your mailbox, multimedia messaging centre, or XHTML or WML pages are shown as data calls or GPRS connections in the general communications log.

Recent calls register

To monitor the phone numbers of missed, received, and dialled calls, press  and select **Tools**→ **Log**→ **Recent calls**. The game deck registers missed and received calls only if the network supports these functions, and the game deck is switched on and within the network's service area.

Erasing recent call lists – To clear all recent call lists, select **Options**→ **Clear recent calls** in the Recent calls main view. To clear one of the call registers, open the register you want to erase and select **Options**→ **Clear list**. To clear an individual event, open a register, scroll to the event, and press .





Tip! You can, for example, divert calls to your voice mailbox number.



Tip! To view a list of sent messages, press  and select **Messaging**→ **Sent**.





Tip! When you see a note in standby mode about missed calls, press **Show** to access the list of missed calls. To call back, scroll to a name or number and press .

 **Tip!** If you want to see the call duration timer while you have an active call, select **Options**→**Settings**→**Show call duration**→**Yes**.

 **Glossary:** Call cost limit - Calls can be made only as long as the preset credit limit (call cost limit) is not exceeded and you are in a network that supports call cost limit. The number of remaining units is shown during a call and in standby mode. When the charging units have expired, the note **Call cost limit reached** is displayed.

Call duration

To monitor the approximate duration of your incoming and outgoing calls, press  and select **Tools**→**Log**→**Call duration**.

 **Note:** The actual time invoiced for calls by your service provider may vary, depending on network features, rounding off for billing, and so forth.

Clearing call duration timers - Select **Options**→**Clear timers**. For this you need the lock code, see 'Security', p. 41. To clear an individual event, scroll to it and press .

Call costs (Network Service)

To check the approximate cost of the last call or all calls, press  and select **Tools**→**Log**→**Call costs**. The call costs are displayed separately for each SIM card.

 **Note:** The actual invoice for calls and services from your service provider may vary, depending on network features, rounding off for billing, taxes and so forth.

Call costs limit set by a service provider

Your service provider can limit the cost of your calls to a certain amount of charging units or currency. Contact your service provider for information on the limited charging mode and charging unit prices. To change the **Show costs in** setting, you may need the PIN2 code, see 'Security', p. 41.

Setting a call cost limit for yourself

- 1 Select **Options**→**Settings**→**Call cost limit**→**On**.
- 2 The game deck requests you to enter the limit in units. For this you may need the PIN2 code. When the charging limit you have set yourself is reached, the counter stops at its maximum value and the note **Reset all calls' cost counter** is displayed. To be able to make calls, go to **Options**→**Settings**→**Call cost limit**→**Off**. For this you need the PIN2 code, see 'Security', 'Device and SIM', p. 41.



Clearing call cost counters - Select **Options**→**Clear counters**. For this you need the PIN2 code, see 'Security', 'Device and SIM', p. 41. To clear an individual event, scroll to it and press .

 **Note:** When no more charging units or currency units are left, calls may only be possible to the official emergency number programmed into the device.

GPRS counter

To check the amount of data sent and received during GPRS connections, press  and select **Tools**→**Log**→**GPRS counter**. For example, you may be charged for your GPRS connections by the amount of data sent and received.

Viewing the general log



To open the general log, press  and select **Tools**→**Log** and press . In the general log, for each communication event, you can see the sender or recipient name, phone number, name of the service provider, or access point. Sub-events, such as a text message sent in more than one part and GPRS connections, are logged as one communication event.

 **Note:** When sending messages, your device may display the word "**Sent**". This is an indication that the message has been sent by your device to the message centre number programmed into your device. This is not an indication that the message has been received at the intended destination. For more details about messaging services, check with your service provider.

Filtering the log: Select **Options**→**Filter**. Scroll to a filter and press **Select**.

Erasing the contents of the log: To erase all the log contents, Recent calls register, and Messaging delivery reports permanently, select **Options**→**Clear log**. Press **Yes** to confirm.

Icons:

-  for incoming,
-  for outgoing, and
-  for missed communication events.

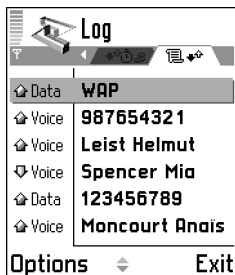



Fig. 7 General log of communication events.

Options in the SIM directory: **Open, Call, New SIM contact, Edit, Delete, Mark/Unmark Copy to Contacts, My numbers, SIM details, Help, and Exit.**

GPRS counter and connection timer: To view how much data, measured in kilobytes, has been transferred and how long a certain GPRS connection has lasted, scroll to an incoming or outgoing event with the access point icon  and select **Options**→ **View details**.

Log settings

Select **Options**→ **Settings**.

- **Log duration** - The log events remain in the game deck memory for a set number of days after which they are automatically erased to free memory.



Note: If you select **No log**, all the log contents, Recent calls register, and Messaging delivery reports are permanently deleted.

- For **Call duration, Show costs in, Call cost limit**, see the sections 'Call duration' and 'Call costs (Network Service)' earlier in this chapter.

SIM directory and other SIM services





Note: For availability, rates and information on using SIM services, contact your SIM card vendor, e.g. network operator, service provider or other vendor.

- Press  and select **Tools**→ **SIM directory** to see the names and numbers stored on the SIM card. In SIM directory you can add, edit, or copy numbers to Contacts, and you can make calls.

To access additional services that your SIM card may provide, press  and select **Tools**. See also: 'Copying contacts between the SIM card and device memory', p. 47, 'Confirm SIM service actions', p. 42, 'Fixed dialling settings', p. 42, and 'Viewing messages on a SIM card', p. 64.

Settings

Changing settings

- 1 Press  and select **Tools**→ **Settings**.
- 2 Scroll to a setting group and press  to open it.
- 3 Scroll to a setting you want to change and press .

Device settings

General

Game auto-start - To allow a game to start automatically when a compatible read-only game card is inserted in the game deck, select **On**.

Device language - Changing the language of the display texts in your game deck will also affect the format used for date and time and the separators used, for example, in calculations. **Automatic** selects the language according to the information on your SIM card. After you have changed the display text language, the game deck restarts.

 **Note:** Changing the settings for **Device language** or **Writing language** affects every application in your game deck and the change remains effective until you change these settings again.

Writing language - Changing the language affects the characters and special characters available when writing text and the predictive text dictionary used.

Dictionary - To set the predictive text input **On** or **Off** for all editors in the game deck. The predictive text dictionary is not available for all languages.

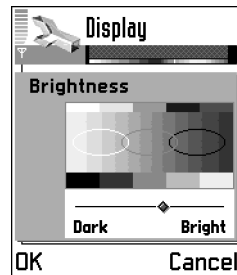

Fig. 8 Adjusting the display brightness.

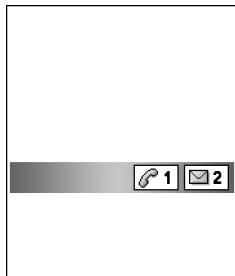



Fig. 9 The screen saver changes to show the number of new messages or missed calls.

Welcome note or logo - The welcome note or logo is displayed briefly each time you switch on the game deck. Select: **Default** to use the default image, **Text** to write a welcome note (max. 50 letters), or **Image** to select a photo or picture from **Images**.

Orig. device settings - You can reset some of the settings to their original values. To do this, you need the lock code. See 'Security', 'Device and SIM', p. 41. After resetting the settings, the game deck may take a longer time to power on. Documents and files are unaffected.

Standby mode

Wallpaper - Select **Yes** to set a background image for standby mode.

Left selection key and **Right selection key** - To change the shortcuts that appear over the left  and right  selection keys in standby mode. Note that you cannot have a shortcut to an application that you have installed.

Display

Brightness - To change the brightness of the display to lighter or darker.

Colour palette - To change the colour palette used on the display.

Screen saver timeout - The screen saver is activated when the timeout period is over.

Screen saver - Select what is shown on the screen saver bar: **Date and time** or **Text** that you have written.





Call settings



Send my caller ID (Network Service) - To set your phone number to be displayed to (**Yes**) or hidden from (**No**) the person to whom you are calling. Or, the value may be set by your network operator or service provider when you make a subscription (**Set by network**).

Call waiting (Network Service) - Select: **Activate** to request the network to activate call waiting, **Cancel** to request the network to deactivate call waiting, or **Check status** to check if the function is active or not.

Automatic redial - Select **On** and your game deck will make a maximum of ten attempts to connect the call after an unsuccessful call attempt. Press  to stop automatic redialling.

Summary after call - Activate this setting if you want the game deck to briefly display the approximate duration of the last call. To show costs, the **Call cost limit** needs to be activated for your SIM card. See 'Call costs (Network Service)', p. 30.



Speed dialling - Select **On** and the numbers assigned to the speed dialling keys ( - ), can be dialled by pressing and holding the key. See also 'Speed dialling a phone number', p. 27.



Anykey answer - Select **On**, and you can answer an incoming call by briefly pressing any key, except , , and .

Line in use (Network Service) - This setting is shown only if the SIM card supports two subscriber numbers, that is, two phone lines. Select which phone line you want to use for making calls and sending text messages. Calls on both lines can be answered irrespective of the selected line.

To prevent line selection, select **Line change** → **Disable** if supported by your SIM card. To change this setting, you need the PIN2 code.

 **Note:** You will not be able to make calls if you select **Line 2** and have not subscribed to this network service.

 **Tip!** To change the settings for call diverting, press  and select **Tools** → **Call divert**. See 'Diverting calls (Network Service)', p. 29.

 **Tip!** To switch between the phone lines, press and hold  in standby mode.





Glossary: A **GSM data call** enables data transmission rates to a maximum of 14.4 kbps. A **High speed data call** (High Speed Circuit Switched Data, HSCSD) enables data transmission rates to a maximum of 43.2 kbps. **GPRS**, General Packet Radio Service, uses packet data technology where information is sent in short packets of data over the mobile network.



Connection settings

About data connections and access points

Your game deck supports three kinds of data connections: a GSM data call () , GSM high-speed data call () , and GPRS connection () . See also 'Essential indicators in standby mode', p. 21. A data connection is required to connect to an access point. There are three different kinds of access points that you can define:

- MMS access point to, for example, send and receive multimedia messages,
- access point for the Web application, to view WML or XHTML pages, and
- Internet access point (IAP) to, for example, send and receive e-mail.

Check with your service provider what kind of an access point is needed for the service you wish to access. For availability and subscription to data call, high speed data call and GPRS connection services, contact your network operator or service provider.

Minimum settings needed to make a data call

To insert a set of very basic GSM data call settings, go to **Tools**→ **Settings**→ **Connection**→ **Access points** and select **Options**→ **New access point**. Fill in the following: **Data bearer:** Data call, **Dial-up number:** obtained from service provider, **Data call type:** Analogue, and **Maximum data speed:** Automatic.



Note: Sending data in HSCSD mode may drain the game deck's battery faster than normal voice or data calls, as the game deck may send data more frequently to the network.

Minimum settings needed to make a GPRS connection

You need to subscribe to the GPRS service. For availability and subscription to GPRS, contact your network operator or service provider. GPRS connections and transmission may be subject to separate fees. See also 'GPRS counter', p. 31.

Go to **Tools**→**Settings**→**Connection**→**Access points** and select **Options**→**New access point**.

Fill in the following: **Data bearer**: GPRS and **Access point name**: enter the name given to you by your service provider. See 'Creating an access point', p. 37.

Creating an access point



Tip! You may receive access point settings in a text message from a service provider. Or, you may have preset access point settings in your game deck. See 'Receiving logos, tones, business cards, calendar entries, and settings', p. 60.

- To create a new access point, go to **Tools**→**Settings**→**Connection**→**Access points**.

If you already have access points, to create a new one select **Options**→**New access point**→**Use default settings** or **Use existing settings** and make the needed changes and press **Back** to save the settings.

Access points

Start to fill in the settings from the top because depending on what data connection you select (**Data bearer**) or whether you need to insert a **Gateway IP address**, only certain setting fields are available. Follow the instructions given to you by your service provider.

Connection name - Give a descriptive name for the connection.

Data bearer - Depending on what data connection you select, only certain setting fields are available. Fill in all fields marked with **Must be defined** or with a red asterisk. Other fields can be left empty, unless you have been instructed otherwise by your service provider.



Note: To be able to use a data connection, the network service provider must support this feature, and if necessary, activate it for your SIM card.



Tip! The Settings wizard program included in the PC Suite for Nokia N-Gage QD can help you to configure access point and mailbox settings. You can also copy existing settings, for example, from your compatible computer to your game deck. See the CD-ROM supplied in the sales package.

Options in the Access points list: **Edit**, **New access point**, **Delete**, **Help**, and **Exit**.

Options when editing access point settings: **Change**, **Advanced settings**, **Help**, and **Exit**.

 **Tip!** See also 'Settings needed for multimedia messaging', p. 58, 'Settings needed for e-mail', p. 59, and 'Basic steps for accessing Web', p. 80.

 **Glossary:** ISDN connections are a way to establish a data call between your game deck and your access point. ISDN connections are digital from end to end and as such offer quicker set-up times and faster data rates than analogue connections.

Access point name (for GPRS only) - The access point name is needed to establish a connection to the GPRS network. You obtain the access point name from your network operator or service provider.

Dial-up number (for GSM data and high speed data only) - The modem telephone number of the access point.

User name - The user name may be needed to make a data connection, and is usually provided by the service provider. The user name is often case-sensitive.

Prompt password - If you must key in a new password every time you log in to a server, or if you do not want to save your password in the game deck, choose **Yes**.

Password - A password may be needed to make a data connection, and is usually provided by the service provider. The password is often case-sensitive.

Authentication - **Normal / Secure**.

Gateway IP address - The IP address that the required WAP gateway uses.

Homepage - Depending on what you are setting up, write either the web address, or the address of the multimedia messaging centre.

Connection security - Choose whether or not Transport Layer Security (TLS) is used for the connection.

Session mode - **Permanent / Temporary**.

Data call type (for GSM data and high speed data only) - Defines whether the game deck uses an analogue or digital connection. This setting depends on both your GSM network operator and Internet Service Provider (ISP), because some GSM networks do not support certain types of ISDN connections. For details, contact your ISP.

Maximum data speed (for GSM data and high speed data only) - The options depend on what you have chosen in **Session mode** and **Data call type**. Allows you to limit the maximum connection speed when high speed data is used. Higher data rates may cost

more, depending on the network service provider. During the connection, the operating speed may be less, depending on network conditions.

Options → Advanced settings

Device IP address - The IP address of your game deck. **Primary name server**: - The IP address of the primary DNS server. **Second. name server**: - The IP address of the secondary DNS server.



Note: If you need to enter the **Device IP address**, **Primary name server**, or **Second. name server**:, contact your Internet service provider to obtain these addresses.

The following settings are shown if you have selected **Data call** as the **Data bearer** when starting to create the access point:

Use callback - This option allows a server to call you back once you have made the initial call. Contact your service provider to subscribe to this service.

Callback type - Ask your service provider for the correct setting to use.

Callback number - Key in your game deck's data phone number that the dial back server uses. Usually, this number is the data call phone number of your game deck.

Use PPP compression - When set to **Yes**, this option speeds up the data transfer, if supported by the remote PPP server. If you have problems establishing a connection, try setting this to **No**. Contact your service provider for guidance.

To insert a login script, select **Use login script** → **Yes**. Insert the login script in **Login script**.

Modem initialisation (Modem initialisation string) - Controls your game deck using modem AT commands. If required, enter characters specified by your GSM network service provider or Internet service provider.

GPRS

The GPRS settings affect all access points using a GPRS connection.



Glossary: DNS - Domain Name Service. An Internet service that translates domain names such as **www.nokia.com** into IP addresses like **192.100.124.195**



Glossary: PPP (Point-to-Point Protocol) - a common networking software protocol that enables any computer with a modem and a phone line to connect directly to the Internet.

GPRS connection - If you select **When available** and you are in a network that supports GPRS, the game deck registers to the GPRS network and text messages will be sent via GPRS. Also, starting an active GPRS connection, for example, to send and receive e-mail, is quicker. If you select **When needed**, the game deck will use a GPRS connection only if you start an application or action that needs it. If there is no GPRS coverage and you have chosen **When available**, the game deck will periodically try to establish a GPRS connection.

Access point - The access point name is needed when you want to use your game deck as a GPRS modem to your computer.

Data call

The Data call settings affect all access points using a data call and high speed data call.

Online time - If there are no actions, the data call is dropped automatically after a time-out period. The options are **User defined**, in which case you enter a time, or **Unlimited**.



Date and time



Tip! See also the Language settings, p. 33.

The date and time settings allow you to define the date and time used in your game deck, as well as to change the date and time format and separators. Choose **Clock type**→ **Analogue** or **Digital** to change the clock shown in standby mode. Choose **Auto time update** if you want the mobile phone network to update time, date, and time zone information to your game deck (Network Service).



Note: For the **Auto time update** setting to take effect, the game deck restarts.



Security

Device and SIM

PIN (Personal Identification Number) code (4 to 8 digits) protects your SIM card against unauthorised use. The PIN code is usually supplied with the SIM card. After three consecutive incorrect PIN code entries, the PIN code is blocked and you need to unblock it before you can use the SIM card again. See the information about PUK code in this section.

PIN2 code (4 to 8 digits) supplied with some SIM cards, is required to access some functions, such as call cost counters.

Lock code (5 digits) can be used to lock the game deck to avoid unauthorised use. The factory setting for the lock code is **12345**. To avoid unauthorised use of your game deck, change the lock code. Keep the new code secret and in a safe place separate from your game deck.

PUK (Personal Unblocking Key) and PUK2 codes (8 digits) are required to change a blocked PIN code or PIN2 code, respectively. If the codes are not supplied with the SIM card, contact the operator whose SIM card is in your game deck.



PIN code request - When active, the code is requested each time the game deck is switched on. Deactivating the PIN code request may not be allowed by some SIM cards.

PIN code / PIN2 code / Lock code - You can change the lock code, PIN code, and PIN2 code. These codes can only include the numbers from **0** to **9**.

Avoid using access codes similar to the emergency numbers to prevent accidental dialling of the emergency number.

Autolock period - You can set an autolock period, a time-out after which the game deck is automatically locked and can be used only if the correct lock code is entered. Key in a number for the time-out in minutes or select **None** to turn off the autolock period.

- To unlock the game deck, key in the lock code.

 **Tip!** To lock the game deck manually, press . A list of commands opens. Select **Lock device**.

Options in the Fixed dialling view: **Open, Call, New contact, Edit, Delete, Add to Contacts, Add from Contacts, Help, and Exit.**

 **Note:** When the device is locked, calls still may be possible to the official emergency number programmed into your device. To make an emergency call while the device is in the offline or flight profiles, you may need to enter the unlock code and change the device to a calling profile before making any call, including a call to an emergency number.

Lock if SIM changed - You can set the game deck to ask for the lock code when an unknown, new SIM card is inserted into your game deck. The game deck maintains a list of SIM cards that are recognised as the owner's cards.

Fixed dialling - You can restrict your outgoing calls to selected phone numbers, if this function is supported by your SIM card. You need the PIN2 code for this function. When this function is active, you can only call those phone numbers that are included in the fixed dialling list or which begin with the same digit(s) as a phone number on the list.

 **Note:** When security features that restrict calls are in use (such as call barring, closed user group and fixed dialling) calls still may be possible to the official emergency number programmed into your device.

To view the list of **Fixed dialling numbers**, press  and select **Tools**→**Fixed dialling**. To add new numbers to the Fixed dialling list, select **Options**→**New contact** or **Add from Contacts**.

Closed user group (Network Service) - To specify a group of people to whom you can call and who can call you, select: **Default** to activate the group agreed on with the network operator, **On** to use another group (you need to know the group index number), or **Off**.

Confirm SIM services (Network Service) - To set the game deck to display confirmation messages when you are using a SIM card service.

Certif. management

Digital certificates do not guarantee safety, they are used to verify the origins of software.

In the Certificate management main view, you can see a list of authority certificates that have been stored in your game deck. Press  to see a list of personal certificates, if available.

Digital certificates should be used if you want to connect to an online bank or another site or remote server for actions that involve transferring confidential information, or want to reduce the risk of viruses or other malicious software and be sure of the authenticity of software when downloading and installing software.



Important: Note that even if the use of certificates makes the risks involved in remote connections and software installation considerably smaller, they must be used correctly in order to benefit from increased security. The existence of a certificate does not offer any protection by itself; the certificate manager must contain correct, authentic, or trusted certificates for increased security to be available. Certificates have a restricted lifetime. If Expired certificate or Certificate not valid yet is shown even if the certificate should be valid, check that the current date and time in your device are correct.

Viewing certificate details – checking authenticity

You can only be sure of the correct identity of a WAP gateway or a server when the signature and the period of validity of a gateway or server certificate have been checked.

You will be notified on the game deck's display: if the identity of the server or gateway is not authentic or if you do not have the correct security certificate in your game deck.

To check certificate details, scroll to a certificate and select **Options**→**Certificate details**. When you open certificate details, Certificate management checks the validity of the certificate and one of the following notes may appear:

- **Certificate not trusted** - You have not set any application to use the certificate. See the next section 'Changing the trust settings of an authority certificate'.
- **Expired certificate** - The period of validity has ended for the selected certificate.
- **Certificate not valid yet** - The period of validity has not yet begun for the selected certificate.



Glossary: Digital certificates are used to verify the origin of the XHTML or WML pages and installed software. However, they can only be trusted if the origin of the certificate is known to be authentic.

Options in the certificate management main view: **Certificate details, Delete, Trust settings, Mark/Unmark, Help, and Exit.**

- **Certificate corrupted** - The certificate cannot be used. Contact the certificate issuer.

Changing the trust settings of an authority certificate



Important: Before changing any certificate settings, you must make sure that you really trust the owner of the certificate and that the certificate really belongs to the listed owner.

Scroll to an authority certificate and select **Options**→**Trust settings**. Depending on the certificate, a list of the applications that can use the selected certificate is shown. For example: **Web: Yes** - the certificate is able to certify sites. **Application manager: Yes** - the certificate is able to certify the origin of new software. **Internet: Yes** - the certificate is able to certify e-mail and imaging servers.



Call barring (Network Service)

Call barring allows you to restrict the making and receiving of calls with your game deck. For this function, you need the barring password from your service provider.

- Scroll to one of the barring options and select **Options**→**Activate** to request the network to set call restriction on, **Cancel** to set the selected call restriction off, or **Check status** to check if the calls are barred or not.
- Select **Options**→**Cancel all barrings** to cancel all active call barrings.
- Select **Options**→**Edit barrings passw.** to change the barring password.



Note: When calls are barred, calls still may be possible to certain official emergency numbers.



Note: Call barring and call diverting cannot be active at the same time.

See 'Diverting calls (Network Service)', p. 29 or 'Fixed dialling', p. 42.

Note that Call barring affects all calls, including data calls.



Network

Operator selection - Select **Automatic** to set the game deck to search for and select one of the networks available, or **Manual** to select the network manually from a list of networks. If the connection to the manually selected network is lost, the game deck will sound an error tone and ask you to reselect a network. The selected network must have a roaming agreement with your home network, that is, the operator whose SIM card is in your game deck.

Cell info display - Select **On** to set the game deck to indicate when it is used in a cellular network based on Micro Cellular Network (MCN) technology and to activate cell info reception.



Enhancement settings - Headset and loopset

Enhancement in use - Select the enhancement you are using.

Headset/ Loopset - Select **Default profile** to set the profile that you want activated each time when you connect a certain enhancement to your game deck. See 'Profiles', p. 71. Select **Automatic answer** to set the game deck to answer an incoming call automatically after five seconds time. If the Incoming call alert is set to **Beep once** or **Silent**, automatic answer cannot be in use.



Glossary: Roaming agreement - An agreement between two or more network service providers to enable the users of one service provider to use the services of other service providers.

Indicators shown in standby mode:

 - a headset is connected.

 - a loopset is connected.

Contacts (Phonebook)

Options in the Contacts directory: **Open, Call, Create message, New contact, Edit, Delete, Duplicate, Add to group, Belongs to groups, Mark/Unmark, Send, Contacts info, Help, and Exit.**

Options when editing a contact card: **Add thumbnail / Remove thumbnail, Add detail, Delete detail, Edit label, Help, and Exit.**

Tip! See 'Imaging', p. 50 for more information on how to store pictures.

You can add a personal ringing tone, voice tag, or a thumbnail image to a contact card. You can also create contact groups, which allow you to send text messages or e-mail to many recipients at the same time. You can add received contact information (business cards) to your Contacts directory. See 'Receiving logos, tones, business cards, calendar entries, and settings', p. 60.







Note: Contact information can only be sent to or received from compatible devices.



Tip! You can move contacts from many different Nokia phones to your game deck using the Data Import application of the PC Suite for Nokia N-Gage QD. Refer to the PC Suite help function for instructions.

Saving names and numbers – Creating and editing contact cards

- 1 Press  and select **Contacts** and select **Options**→ **New contact**.
- 2 Fill in the fields that you want and press **Done**.
 - **To edit contact cards**, in the Contacts directory, scroll to the contact card and press . To change the information on the card, select **Options**→ **Edit**.
 - **To delete contact cards**, in the Contacts directory, scroll to the contact card and select **Options**→ **Delete**.
 - **To attach a small thumbnail image to a contact card**, open the contact card, select **Options**→ **Edit** and then select **Options**→ **Add thumbnail**. The thumbnail image is shown when the contact calls.
 - **To add an image to a contact card**, open a contact card, and press  to open the Image view (). To attach an image, select **Options**→ **Add image**.

Copying contacts between the SIM card and device memory

- To copy names and numbers from a SIM card to your game deck, press  and select **Tools**→**SIM directory**. Select the name(s) you want to copy and select **Options**→**Copy to Contacts**.
- To copy a telephone, fax, or pager number from Contacts to your SIM card, go to Contacts and open a contact card. Scroll to the number, and select **Options**→**Copy to SIM direct**.

Adding a ringing tone for a contact card or group

When a contact or group member calls you, the game deck plays the chosen ringing tone (if the caller's telephone number is sent with the call and your game deck recognises it).

- 1 Press  to open a contact card or go to the Groups list and select a contact group.
 - 2 Select **Options**→**Ringing tone**. A list of ringing tones opens.
 - 3 Scroll to the ringing tone you wish to use for the contact or group and press **Select**.
- To remove the ringing tone, select **Default tone** from the list of ringing tones.



Note: For an individual contact, the game deck uses the ringing tone that was assigned last. So, if you first change a group ringing tone and then the ringing tone of a single contact that belongs to that group, the ringing tone of the single contact is used.

Voice dialling

You can make a phone call by saying a voice tag that has been added to a contact card. Any spoken word(s) can be a voice tag.



Tip! To send contact information, in the Contacts directory, scroll to the card you want to send. Select **Options**→**Send**→**Via text message**, **Via e-mail** (available only if the correct e-mail settings are in place) or **Via Bluetooth**. See the 'Messaging' chapter, and 'Sending data via Bluetooth', p. 89.



Tip! Speed dialling is a quick way to call frequently used numbers. You can assign speed dialling keys to eight phone numbers. See 'Speed dialling a phone number' on p. 27.

 **Example:** You can use a person's name as a voice tag, for example, 'John's mobile'.

 **Tip!** To view a list of voice tags you have defined, select **Options**→**Contacts info**→**Voice tags** in the Contacts directory.

Before using voice tags, note that:

- Voice tags are not language-dependent. They are dependent on the speaker's voice.
- You must say the name exactly as you said it when you recorded it.
- Voice tags are sensitive to background noise. Record voice tags and use them in a quiet environment.
- Very short names are not accepted. Use long names and avoid similar names for different numbers.



Note: Using voice tags may be difficult in a noisy environment or during an emergency, so you should not rely solely upon voice dialling in all circumstances.

Adding a voice tag to a phone number

You can have only one voice tag per contact card. You can add a voice tag to up to 25 phone numbers.

- 1 In the Contacts directory, open the contact card to which you want to add a voice tag.
- 2 Scroll to the number to which you want to add the voice tag and select **Options**→**Add voice tag**.
- 3 Press **Start** to record a voice tag. After the starting tone, say clearly the word(s) you want to record as a voice tag. Wait until the game deck plays the recorded tag and saves it. A symbol  can be seen next to the number in the contact card indicating that a voice tag has been added to it.

Making a call by saying a voice tag

You must say the voice tag exactly as you said it when you recorded it.



- 1 In standby mode, press and hold . A short tone is played and the note *Speak now* is displayed.
- 2 When you are making a call by saying a voice tag, the loudspeaker is in use. Hold the game deck at a short distance away and say the voice tag clearly.

- 3 The game deck plays the original voice tag, displays the name and number, and dials the number of the recognised voice tag.
- If the game deck plays the wrong voice tag or you want to retry voice dialling, press **Retry**.



Note: Voice dialling cannot be used when a data call or a GPRS connection is active.

Creating contact groups

- 1 In the Contacts directory, press  to open the Groups list.
- 2 Select **Options**→ **New group**.
- 3 Write a name for the group or use the default name **Group** and press **OK**.
- 4 Open the group and select **Options**→ **Add members**.
- 5 Scroll to a contact and press  to mark it. To add multiple members at a time, repeat this action on all the contacts you want to add.
- 6 Press **OK** to add the contact(s) to the group.

Removing members from a group

- 1 In the Groups list, open the group you want to modify.
- 2 Scroll to the contact and select **Options**→ **Remove from group**.
- 3 Press **Yes** to remove the contact from the group.



 **Tip!** To listen to, change, or delete a voice tag, open a contact card and scroll to the number that has a voice tag (indicated by ) and select **Options**→ **Voice tags**. Then select either **Playback**, **Change**, or **Delete**.



Fig. 10 Creating a contact group.

Imaging



Images – Viewing images

Options in Images: **Open**, **Send**, **Image uploader**, **Delete**, **Move to folder**, **New folder**, **Mark/Unmark**, **Rename**, **View details**, **Add to 'Go to'**, **Update thumbnails**, **Help**, and **Exit**.



Fig. 11 The Images main view.

Images can be saved from Screen shot or sent to you in a multimedia or picture message, as an e-mail attachment, or via Bluetooth. After receiving an image in Inbox, you need to save it in the device memory or on a memory card. You can save graphics sent to you in picture messages to the Picture messages folder.

- 1 Press and select **Extras**→ **Images**. Press or to move from one memory tab to another. To browse the images, press and .
- 2 Press , to open an image. When the image is open, you can see the name of the image and the number of images in the folder on the top of the display.

Keyboard shortcuts

- Rotate: - anticlockwise, - clockwise.
- Scroll: - up, - down, - left, - right.
- Zoom: - in, - out, and press and hold to return to the normal view.
- View: - change between full screen and normal view.





Tip! You can send images via different messaging services to compatible devices.



Screen shot

You can capture images from the screen of your game deck. Screen shot runs in the background and captures the screen contents when you press the designated key combination.

Note that inserting a game or a memory card closes all applications that are open in the device. If you want to take a screen shot from a game, insert a game card first and then open the Screen shot application.

- 1 Press  and select **Extras**→ **Screen shot**.
- 2 Select **Options**→ **Keep app. active**. The application disappears from the screen. Screen shot remains active. It has no effect on any application you want to run, and it lets you capture the screen contents anytime, for example, when you are playing a game.
- 3 Press  +  to capture a screen shot. Screen shots are automatically saved to **Images**.



Note: If memory is getting low, the game deck may close some applications. The game deck saves any unsaved data before an application is closed.

Changing Screen shot settings

Select **Options**→ **Settings** to change:

- **Take scr. shot with** - Select a key combination to take screen shots with.
- **Folder name, Screen shot name, Screen shot quality**,
- **Use default name** - Select **Yes** if you want to save the image using the name you entered in the **Screen shot name** option. Select **No** to set an individual name for every image (the name you entered in the **Screen shot name** option is displayed by default).



Video player

Press  and select **Extras**→ **Vid. player** to play video clips stored in device memory or on a memory card.

Video player supports files with extensions .3gp and .nim. Note that all variations of the file formats are not necessarily supported.

- **To play a video clip**, scroll to it and press  or select **Options**→ **Open**.
- **To send a video clip**, scroll to the video clip you want to send and select **Options**→ **Send**→ **Via multimedia**, **Via e-mail**, or **Via Bluetooth**. Select a recipient. The video clip is moved to Outbox for sending. Because of the maximum size of the multimedia

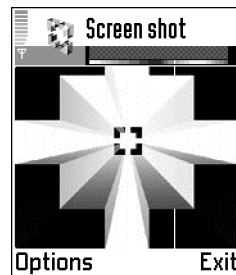

Fig. 12 Screen shot.

Options in the main view:
Open, **Delete**, **Edit clip name**, **Send**, **Add to 'Go to'**, **Move to mem. card/Move to device mem.**, **Settings**, and **Exit**.

- message is 95 kB, the length of the recorded video clip is limited to 95 kB, which usually means approximately 15 seconds.
- To turn the sound on or off, adjust the contrast of the display, or to have the playing of video clips restart automatically once they have finished, select **Options**→**Settings**.

Receiving a video clip in a message

- When you receive a video clip in a supported format in a multimedia message, go to **Messaging** and open the multimedia message. To view the message as text and to play the video or save it, select **Options**→**Objects**.
- When you receive a video clip in a supported format as an e-mail attachment, open the message and select **Options**→**Attachments** if you want to play or save the video.

Messaging

In Messaging, you can create, send, receive, view, edit, and organise: text messages, multimedia messages, e-mail messages, and special text messages containing data. You can also receive messages and data via Bluetooth, receive Web service messages, cell broadcast messages as well as send service commands.



Note: These functions can only be used if they are supported by your network operator or service provider. Only devices that offer compatible, picture message, multimedia message, or e-mail features can receive and display these messages. Some networks might provide the recipient device with a Web page link to view multimedia messages.

When you open Messaging, you can see the **New message** function and a list of folders:



Inbox - contains received messages except e-mail and cell broadcast messages. E-mail messages are stored in the **Mailbox**.



My folders - for organising your messages into folders.



Mailbox - When you open this folder, you can either connect to your remote mailbox to retrieve your new e-mail messages or view your previously retrieved e-mail messages offline. See 'Settings for e-mail', p. 68.



Drafts - stores draft messages that have not been sent.



Sent - stores the last 20 messages that have been sent other than those sent via Bluetooth. To change the number of messages to be saved, see 'Settings for the Other folder', p. 70.



Outbox - is a temporary storage place for messages waiting to be sent.





Options in the Messaging main view: **Create message**, **Connect** (shown if you have defined mailbox settings) / **Disconnect** (shown if a connection to mailbox is active), **SIM messages**, **Cell broadcast**, **Service command**, **Settings**, **Help**, and **Exit**.



Tip! Organise your messages by adding new folders under **My folders**.



Tip! When you have opened any of the default folders, you can switch between the folders by pressing  or .













Icons: **ABC** and **abc** indicate the selected case. **ABC** means that the first letter of the word, is written in upper case, and all the other letters will automatically be written in lower case. **123** indicates number mode.

Reports- you can request the network to send you a delivery report of the text messages and multimedia messages you have sent (Network Service). Receiving a delivery report of a multimedia message that has been sent to an e-mail address might not be possible.

Writing text













Traditional text input

The indicator  is shown on the top right of the display when you are writing text using traditional text input.





- Press a number key ( - ) repeatedly until the desired character appears. Note, that there are more characters available for a number key than are printed on the key.
- To insert a number, press and hold the number key.
- To switch between letter and number mode, press and hold .
- If the next letter is located on the same key as the present one, wait until the cursor appears (or press  to end the time-out period), and then key in the letter.
- If you make a mistake, press  to remove a character. Press and hold  to clear more than one character.
- The most common punctuation marks are available under . Press  repeatedly to reach the desired punctuation mark. Press  to open a list of special characters. Use  to move through the list and press **Select** to select a character.
- To insert a space, press . To move the cursor to the next line, press  three times.
- To switch between the different character cases **Abc**, **abc**, and **ABC** press .



Predictive text input – Dictionary

You can key in any letter with a single keypress. The predictive text input is based on a built-in dictionary to which you can also add new words. When the dictionary becomes full, the latest added word replaces the oldest.

- 1 To activate predictive text input, press  and select **Dictionary on**. This will activate predictive text input for all editors in the game deck. The indicator  is shown on the top right of the display when you are writing text using predictive text input.
- 2 Write the desired word by pressing the keys  - . Press each key only once for one letter. For example, to write 'Nokia' when English dictionary is selected, press  for N,  for o,  for k,  for i, and  for a. As you can see in Fig. 13, the word suggestion changes after each key press.
- 3 When you have finished writing the word and it is correct, confirm it by pressing  or adding a space by pressing .
 - If the word is not correct: Press  repeatedly to view the matching words the dictionary has found one by one. Or, press  and select **Dictionary**→ **Matches**.
 - If the ? character is shown after the word, the word you intended to write is not in the dictionary. To add a word to the dictionary, press **Spell**, key in the word (max. 32 letters) using traditional text input, and press **OK**. The word is added to the dictionary. When the dictionary becomes full, a new word replaces the oldest added word.
- 4 Start writing the next word.

Tips on using predictive text input

- To erase a character, press . Press and hold  to clear more than one character.
- To change between the different character cases **Abc**, **abc**, and **ABC**, press . Note that if you press  quickly twice the predictive text input is turned off.
- To insert a number in letter mode, press and hold the desired number key.

 **Tip!** To set predictive text input on or off, press  twice quickly when writing text.

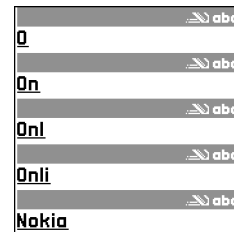













Fig. 13 The word match is evolving, wait until you have keyed in the whole word before you check the results.



 **Tip!** The predictive text input will try to guess which commonly used punctuation mark (.,?!') is needed. The order and availability of the punctuation marks depend on the language of the dictionary.

 **Tip!** When you press  , the following options appear (depending on the editing mode and situation you are in):

Dictionary (predictive text input), **Alpha mode** (traditional text input), **Number mode**, **Cut** (if text has been selected), **Copy** (if text has been selected), **Paste** (when text has been cut or copied first), **Insert number**, **Insert symbol**, and **Writing language**: (changes the input language for all editors in the game deck).

- To switch between letter and number mode, press and hold .
- The most common punctuation marks are available under  . Press  and then .
- Press and hold  to open a list of special characters.
- Press  repeatedly to view the matching words the dictionary has found one by one.
- Press  , select **Dictionary** and press  to select one of the following options:
 - Matches** to view a list of words that correspond to your key presses.
 - Insert word** to add a word (max. 32 letters) to the dictionary by using traditional text input. When the dictionary becomes full, a new word replaces the oldest added word.
 - Edit word** to edit the word using traditional text input, available if the word is active (underlined).











Writing compound words

Write the first half of a compound word and confirm it by pressing  . Write the last part of the compound word and complete the compound word by pressing  to add a space.

Turning predictive text input off

- Press  and select **Dictionary** → **Off** to turn predictive text input off for all editors in the game deck.

Copying text to clipboard



- To select letters and words, press and hold  . At the same time, press  or .
- To end the selection, stop pressing .
- To copy the text to clipboard, while still holding  , press **Copy**.
- To insert the text into a document, press and hold  and press **Paste**. Or, press  once and select **Paste**.
 - To select lines of text, press and hold  . At the same time press  or .
 - If you want to remove the selected text from the document, press .

Writing and sending messages

The appearance of a multimedia message may vary depending on the receiving device.

Copyright protections may prevent some images, ringing tones, and other content from being copied, modified, transferred, or forwarded.

Note that before you can create a multimedia message or write an e-mail, you must have the correct connection settings in place. See 'Settings needed for e-mail', p. 59 and 'Settings needed for multimedia messaging', p. 58.

- 1 Select **New message**. A list of message options opens.
 - Select **Create: Text message** if you want to create a text message.
 - Select **Create: Multimedia message** if you want to send a multimedia message (MMS).
 - Select **Create: E-mail** to send e-mail. If you have not set up your e-mail account, you will be prompted to do so.
- 2 Press  to select recipient(s) from the Contacts directory or key in the recipient's phone number or e-mail address. Pressing  adds a semicolon (;) that separates each recipient.
- 3 Press  to move to the message field.
- 4 Write the message.
 - To add a picture to a text message, select **Options**→**Insert**→**Picture**.



Note: Your device supports the sending of text messages beyond the normal 160-character limit. If your message exceeds 160 characters, it will be sent as a series of two or more messages and sending may cost you more. In the navigation bar, you can see the message length indicator counting backwards from 160. For example, 10 (2) means that you can still add 10 characters for the text to be sent as two messages. Note that some characters may take more space than others.

- To add a media object to a multimedia message, select **Options**→**Insert**→**Image**, **Sound clip**, **Video clip**, or **Template**. When sound has been added, the  icon is



Tip! You can start to create a message from any application that has the option **Send**. Select a file (an image, text) to be added to the message and select **Options**→**Send**.



Tip! Scroll to a contact and press  to mark it. You can mark several recipients at a time.

Options in the message editor: **Send**, **Add recipient**, **Insert**, **Attachments** (e-mail), **Preview message** (MMS), **Objects** (MMS), **Remove** (MMS), **Delete**, **Message details**, **Sending options**, **Help**, and **Exit**.

shown in the navigation bar. A multimedia message can contain only one image and one sound clip.

 **Tip!** The default setting is **Image size: Large** (network dependent). When you are sending a multimedia message to an e-mail address or a device that supports the receiving of large images, use the larger image size. If you are not sure of the receiving device or the network does not support the sending of large files, it is recommended to use a smaller image size and a sound clip that is no longer than 15 seconds. To change the setting, select **Options**→**Sending options**→**Image size** when you are creating a multimedia message.

If you select **Insert**→**New sound clip**, Recorder opens and you can record a new sound. Press **OK** and the new sound is automatically saved and a copy is inserted in the message. Select **Options**→**Preview message** to see what the multimedia message will look like.



- To add an attachment to an e-mail, select **Options**→**Insert**→**Image, Sound clip, Video clip** or **Note**. E-mail attachments are indicated by  in the navigation bar.
 - 5 To send the message, select **Options**→**Send** or press .
-  **Note:** E-mail messages are automatically placed in Outbox before sending. If sending does not succeed, the e-mail is left in the Outbox with the status **Failed**.



Fig. 14 Creating a multimedia message.

Settings needed for multimedia messaging

You may receive the settings in a text message from your network operator or service provider. See 'Receiving logos, tones, business cards, calendar entries, and settings', p. 60.

For availability of and subscription to data services, please contact your network operator or service provider. Follow the instructions given by your service provider.

Entering the settings manually:

- 1 Go to **Tools**→**Settings**→**Connection**→**Access points** and define the settings for a multimedia messaging access point. See 'Connection settings', p. 36.

- 2 Go to **Messaging**→**Options**→**Settings**→**Multimedia message**. Open **Access point in use** and select the access point you created to be used as the preferred connection. See also 'Settings for multimedia messages', p. 66.



Settings needed for e-mail

Before you can send, receive, retrieve, reply to, and forward e-mail, you must:

- Configure an Internet Access Point (IAP) correctly. See 'Connection settings', p. 36.
- Define your e-mail settings correctly. See 'Settings for e-mail', p. 68. You need to have a separate e-mail account. Follow the instructions given by your remote mailbox and Internet Service Provider (ISP).







Inbox - receiving messages

When you receive a message,  and the text **1 new message** are shown in standby mode. Press **Show** to open the message. To open a message in Inbox, scroll to it and press .

Receiving multimedia objects







Important: Multimedia message objects may contain viruses or otherwise be harmful to your device or PC. Do not open any attachment if you are not sure of the trustworthiness of the sender.

When you open a multimedia message () , you may see an image, read a message, and hear a sound through the loudspeaker ( is shown if sound is included), simultaneously. If sound is playing, press  or  to increase or decrease the sound volume. To mute the sound, press **Stop**. To listen to a sound again, select **Options**→**Play sound clip**.

 **Tip!** To send files other than sounds and notes as attachments, open the appropriate application and select **Send**→**Via e-mail**, if available.

Inbox icons:

When there are unread messages in Inbox, the icon changes to  ,  unread text message,  unread multimedia message, and  data received via Bluetooth.

Options in the Objects view: **Open**, **Save**, **Send**, **Help**, and **Exit**.

 **Tip!** If you receive a vCard file that has a picture attached, the picture will be saved to Contacts as well.

 **Tip!** To change the default access point settings for multimedia messaging, go to **Messaging**→**Options**→**Settings**→**Multimedia message**→**Access point in use**.

To see what kinds of media objects have been included in the multimedia message, open the message and select **Options**→**Objects**. You can choose to save a multimedia object file in your game deck or send it, for example, via Bluetooth to another compatible device.

Copyright protections may prevent some images, ringing tones, and other content from being copied, modified, transferred, or forwarded.

Receiving logos, tones, business cards, calendar entries, and settings

Your game deck can receive many kinds of text messages that contain data ()¹, also called Over-The-Air (OTA) messages:

- **Picture message** - To save the picture for later use in **Extras**→**Images**→**Picture msgs.**, select **Options**→**Save picture**.
- **Business card** - To save the contact information, select **Options**→**Save business card**.
 **Note:** If certificates or sound files are attached, they will not be saved.
- **Ringing tone** - To save the ringing tone to Composer, select **Options**→**Save**.
- **Operator logo** - For the logo to be shown in standby mode instead of the network operator's own identification, select **Options**→**Save**.
- **Calendar entry** - To save the invitation, select **Options**→**Save to Calendar**.
- **Web message** - To save the bookmark to the Bookmarks list in Web, select **Options**→**Save to bookmarks**. If the message contains both access point settings and bookmarks, to save the data select **Options**→**Save all**.
- **E-mail notification** - Tells you how many new e-mails you have in your remote mailbox. An extended notification may list more detailed information.
- In addition, you can receive a text message service number, voice mailbox number, profile settings for remote synchronisation, access point settings for the Web application, multimedia messaging or e-mail, access point login script settings, or e-mail settings.

Receiving service messages

Service messages (🌐) are notifications of, for example, news headlines and may contain a text message or a link. For availability and subscription, contact your service provider.

My folders

In My folders, you can organise your messages into folders, create new folders, and rename and delete folders. Select **Options**→ **Move to folder**, **New folder**, or **Rename folder**.

Mailbox

If you select **Mailbox** and have not set up your e-mail account, you will be prompted to do so. See 'Settings needed for e-mail', p. 59. When you create a new mailbox, the name you give to the mailbox replaces **Mailbox** in the Messaging main view. You can have several mailboxes (max. six).

Opening the mailbox

When you open the mailbox, you can choose whether you want to view the previously retrieved e-mail messages and e-mail headings offline or connect to the e-mail server.

When you scroll to your mailbox and press , the game deck asks you if you want to **Connect to mailbox?**

- Select **Yes** to connect to your mailbox and retrieve new e-mail headings or messages. When you are viewing messages online, you are continuously connected to a remote mailbox via a data call or a GPRS connection. See also 'Essential indicators in standby mode', p. 21 and 'Connection settings', p. 36.
- Select **No** to view previously retrieved e-mail messages offline. When you view e-mail messages offline, your game deck is not connected to the remote mailbox.

 **Tip!** You can use texts in the Templates folder to avoid rewriting messages that you send often.

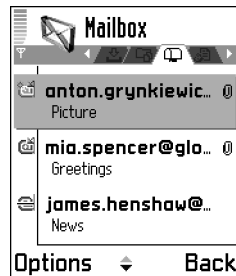



Fig. 15 Mailbox with different status icons.





Tip! You can use the PC Suite for Nokia N-Gage QD on a compatible PC to configure access point and mailbox settings. See the CD-ROM supplied in the sales package.

E-mail status icons:

 new e-mail (offline or online mode), the content has not been retrieved to your game deck (arrow outwards).



 new e-mail, the content has been retrieved to your game deck (arrow inwards).

 e-mail message has been read.

 e-mail heading that has been read and the message content has been deleted from the game deck.

Retrieving e-mail messages from the mailbox

- If you are offline, select **Options**→**Connect** to start a connection to a remote mailbox.
-  **Important:** E-mail messages may contain viruses or otherwise be harmful to your device or PC. Do not open any attachment if you are not sure of the trustworthiness of the sender.

- 1 When you have an open connection to a remote mailbox, select **Options**→**Retrieve e-mail**→
 - **New** - to retrieve all new e-mail messages to your game deck.
 - **Selected** - to retrieve only the e-mail messages that have been marked.
 - **All** - to retrieve all messages from the mailbox.
 To cancel retrieving, press **Cancel**.
- 2 After you have retrieved the e-mail messages, you can continue viewing them online. Or, select **Options**→**Disconnect** to close the connection and to view the e-mail messages offline.
- 3 To open an e-mail message, press . If the e-mail message has not been retrieved (arrow in the icon is pointing outwards) and you are offline, you will be asked if you want to retrieve this message from the mailbox.
 - To view e-mail attachments, open a message that has the attachment indicator  and select **Options**→**Attachments**. If the attachment has a dimmed indicator, it has not been retrieved to the game deck, select **Options**→**Retrieve**. In the Attachments view, you can retrieve, open, or save attachments. You can also send attachments via Bluetooth.



Tip! If your mailbox uses the IMAP4 protocol, you can decide whether to retrieve e-mail headings only, messages only, or messages and attachments. With the POP3 protocol, the options are e-mail headings only or messages and attachments. See 'Settings for e-mail', p. 68.

Deleting e-mail messages

- To delete an e-mail content from the game deck while still retaining it in the remote mailbox, select **Options**→ **Delete**→ **Device only**.



Note: The game deck mirrors the e-mail headings in the remote mailbox. So, although you delete the message content, the e-mail heading stays in your game deck. If you want to remove the heading as well, you have to first delete the e-mail message from your remote mailbox and then make a connection from your game deck to the remote mailbox again to update the status.

- To delete an e-mail from both the game deck as well as from the remote mailbox. Select **Options**→ **Delete**→ **Device and server**.



Note: If you are offline, the e-mail will be deleted first from your game deck. During the next connection to the remote mailbox, it will be automatically deleted from the remote mailbox. If you are using the POP3 protocol, messages marked to be deleted are removed only after you have closed the connection to the remote mailbox.

- To cancel deleting an e-mail from both the game deck and server, scroll to an e-mail that has been marked to be deleted during the next connection (☰), and select **Options**→ **Undelete**.



Tip! To copy an e-mail from the remote mailbox to a folder under My folders, select **Options**→ **Copy to folder**. Select a folder from the list and press **OK**.

Disconnecting from the mailbox

When you are online, select **Options**→ **Disconnect** to end the data call or GPRS connection to the remote mailbox. See also 'Essential indicators in standby mode', p. 21.

Viewing e-mail messages when offline

When you open **Mailbox** the next time and you want to view and read the e-mail messages offline, answer **No** to the **Connect to mailbox?** query. You can read the previously retrieved e-mail headings and/or the retrieved e-mail messages. You can also write new, reply to, or forward e-mail to be sent the next time you connect to the mailbox.

 **Example:** Messages are placed to Outbox, for example, when your game deck is outside network coverage. You can also schedule e-mail messages to be sent the next time you connect to your remote mailbox.



Outbox - Messages waiting to be sent

Status of the messages in Outbox: **Sending, Waiting /Queued, Resend at (time)** - The game deck will try to send the message again after a time-out period. Press **Send** to restart the sending immediately. **Deferred** - You can set documents to be 'on hold' while they are in Outbox. Scroll to a message that is being sent and select **Options**→ **Defer sending**. **Failed** - The maximum number of sending attempts has been reached. Sending has failed. If you were trying to send a text message, open the message and check that the Sending options are correct.

Viewing messages on a SIM card

Before you can view SIM messages, you need to copy them to a folder in your game deck.

- 1 In the Messaging main view, select **Options**→ **SIM messages**.
- 2 Select **Options**→ **Mark/Unmark**→ **Mark** or **Mark all** to mark messages.
- 3 Select **Options**→ **Copy**. A list of folders opens.
- 4 Select a folder and press **OK**. Go to the folder to view the messages.



Cell broadcast (Network Service)

Options in Cell broadcast:
Open, Subscribe / Unsubscribe, Hotmark / Remove hotmark, Topic, Settings, Help, and Exit.

You may be able to receive messages on various topics, such as weather or traffic conditions from your service provider. For available topics and relevant topic numbers, contact your service provider. In the Messaging main view, select **Options**→ **Cell broadcast**. In the main view you can see the status of a topic, a topic number, name, and whether it has been flagged (🚩) for follow-up.



Note: A GPRS connection may prevent cell broadcast reception. Contact your network operator for the correct GPRS settings. See 'Connection settings', p. 36.



Service command editor

Select **Messaging**→**Options**→**Service command**. Key in and send service requests (also known as USSD commands), such as activation commands for network services, to your service provider.

Messaging settings

Settings for text messages

Go to **Messaging**→**Options**→**Settings**→**Text message**.





- **Message centres** - Lists all the text message service centres that have been defined. See 'Adding a new text message centre', p. 65.
- **Msg. centre in use** - Select which message centre is used for delivering text messages.
- **Receive report (Network Service)** - To request the network to send delivery reports on your messages. When set to **No**, only the status **Sent** is shown in Log. See p. 29.
- **Message validity** - If the recipient of a message cannot be reached within the validity period, the message is removed from the text message service centre. Note that the network must support this feature. **Maximum time** is the maximum amount of time allowed by the network.
- **Message sent as** - Change this option only if you are sure that your service centre is able to convert text messages into these other formats. Contact your network operator.
- **Preferred connection** - You can send text messages via the normal GSM network or via GPRS, if supported by the network. See 'GPRS', p. 39.
- **Reply via same ctr. (Network Service)** - Choose **Yes**, if you want the reply message to be sent using the same text message service centre number.

Adding a new text message centre

- 1 Open **Message centres** and select **Options**→**New msg. centre**.



Options when editing text message centre settings:
New msg. centre, Edit, Delete, Help, and Exit.

 **Example:** If your preferred connection uses GPRS, you may want to use GSM data call for the secondary connection. This way you are able to send and receive multimedia messages even when you are not in a network that supports GPRS. Contact your network operator or service provider. See 'About data connections and access points', p. 36.

- 2 Press , write a name for the service centre and press **OK**.
- 3 Press , press  and write the number of the text message service centre. You receive the number from your service provider.
- 4 Press **OK**.
- 5 To take the new settings into use, go back to the settings view. Scroll to **Msg. centre in use**, press  and select the new service centre.

Settings for multimedia messages

Go to **Messaging**→**Options**→**Settings**→**Multimedia message**.

- **Access point in use (Must be defined)** - Select which access point is used as the preferred connection for the multimedia message centre. See 'Settings needed for multimedia messaging', p. 58.
 -  **Note:** If you receive multimedia message settings in a text message and save them, the received settings are automatically used for the Preferred connection. See 'Receiving logos, tones, business cards, calendar entries, and settings', p. 60.
- **Secondary conn.**- Select which access point is used as the secondary connection for the multimedia message centre.
 -  **Note:** Both **Access point in use** and **Secondary conn.** must have the same **Homepage** setting pointing to the same multimedia service centre. Only the data connection is different.
- **Multimedia reception**
 The default setting of the multimedia message service is generally on.
 -  **Note:** When you are outside your home network, sending and receiving multimedia messages may cost you more. If the settings **Only in home net.** or **Always on** have been selected, your game deck can make an active data call or GPRS connection without your knowledge.

Select **Only in home net.** if you want to receive multimedia messages only when you are in your home network. When you are outside your home network, multimedia

message reception is turned off. Select **Always on** if you want to receive multimedia messages always. Select **Off** if you do not want to receive multimedia messages or advertisements at all.

- **On receiving msg.** - Select:
 - Retr. immediately** - if you want the game deck to retrieve multimedia messages instantly. If there are messages with Deferred status, they will be retrieved as well.
 - Defer retrieval** - if you want the multimedia messaging centre to save the message to be retrieved later. To retrieve the message later, set **On receiving msg.** to **Retr. immediately.**
 - Reject message** - if you want to reject multimedia messages. The multimedia messaging centre will delete the messages.
- **Allow anon. messages** - Select **No**, if you want to reject messages coming from an anonymous sender.
- **Receive adverts** - Define whether you want to receive multimedia message advertisements or not.
- **Receive report** (Network Service) - Set to **Yes**, if you want the status of the sent message to be shown in the Log.

 **Note:** Receiving a delivery report of a multimedia message that has been sent to an e-mail address might not be possible.
- **Deny report sending** - Choose **Yes**, if you do not want your game deck to send delivery reports of received multimedia messages.
- **Message validity** - If the recipient of a message cannot be reached within the validity period, the message is removed from the multimedia messaging centre. Note that the network must support this feature. **Maximum time** is the maximum amount of time allowed by the network.
- **Image size** - Define the size of the image in a multimedia message. The options are: **Small** (max. of 160*120 pixels) and **Large** (max. 640*480 pixels).
- **Default speaker** - Choose **Loudspeaker** or **Handset**, if you want the sounds in a multimedia message to be played through the loudspeaker or the earpiece. See Loudspeaker, p. 25.



Options when editing e-mail settings: **Edit, New mailbox, Delete, Help, and Exit.**

Settings for e-mail

Go to **Messaging**→**Options**→**Settings**→**E-mail** and select:

Mailbox in use to select which mailbox you want to use for sending e-mail.

Mailboxes to open a list of mailboxes that have been defined. If no mailboxes have been defined, you will be prompted to do so. Select a mailbox to change the settings:

- **Mailbox name** - Write a descriptive name for the mailbox.
- **Access point in use (Must be defined)** - To choose an Internet Access Point (IAP) for the mailbox. See 'Connection settings', p. 36.
- **My e-mail address (Must be defined)** - Write the e-mail address given to you by your service provider. Replies to your messages are sent to this address.
- **Outgoing mail server: (Must be defined)** - Write the IP address or host name of the computer that sends your e-mail.
- **Send message** - Define how e-mail is sent from your game deck.
Immediately - The device starts to establish a connection to the mailbox after you have selected **Send**. **During next conn.** - E-mail is sent when you connect to your remote mailbox the next time.
- **Send copy to self** - Select **Yes** to save a copy of the e-mail to your remote mailbox and to the address defined in **My e-mail address**.
- **Include signature** - Select **Yes** if you want to attach a signature to your e-mail message and to start to write or edit a signature text.
- **User name:** - Write your user name, given to you by your service provider.
- **Password:** - Write your password. If you leave this field blank, you will be prompted for the password when you try to connect to your remote mailbox.
- **Incoming mail server: (Must be defined)** - The IP address or host name of the computer that receives your e-mail.
- **Mailbox type:** - Defines the e-mail protocol that your remote mailbox service provider recommends. The options are **POP3** and **IMAP4**. This setting can be selected only once and cannot be changed if you have saved or exited from the mailbox settings. If you are

using the POP3 protocol, e-mail messages are not updated automatically in online mode. To see the latest e-mail messages, you need to disconnect and then make a new connection to your mailbox.

- **Security** - Used with the POP3, IMAP4, and SMTP protocols to secure the connection to the remote mailbox.
- **APOP secure login** (not shown if IMAP4 is selected for **Mailbox type**;) - Used with the POP3 protocol to encrypt the sending of passwords to the remote e-mail server.
- **Retrieve attachment** (not shown if the e-mail protocol is set to POP3) - To retrieve e-mail with or without attachments.
- **Retrieve headers**- To limit the number of e-mail headers you want to retrieve to your game deck. The options are **All** and **User defined** (can only be used with the IMAP4 protocol).

Settings for service messages

Go to **Messaging**→**Options**→**Settings**→**Service message**. Choose whether or not you want to receive service messages. **Authentic. needed** - Choose if you want to receive service messages only from authorised sources.

Settings for Cell broadcast (Network Service)

Check with your service provider what the available topics and related topic numbers are and go to **Messaging**→**Options**→**Settings**→**Cell broadcast** to change the settings.

- **Language** - **All** allows you to receive cell broadcast messages in all supported languages. **Selected** allows you to choose in which languages you wish to receive cell broadcast messages. If you cannot find the desired language, select **Other**.
- **Topic detection** - If you receive a message that does not belong to any of the existing topics, **Topic detection**→**On** allows you to save the topic number automatically. The topic number is saved to the topic list and shown without a name. Choose **Off** if you do not want to save new topic numbers automatically.

Settings for the Other folder

Go to **Messaging** and select **Options**→**Settings**→**Other**.

- **Save sent messages** - Choose if you want to save a copy of every text message, multimedia message, or e-mail that you have sent to the Sent items folder.
- **No. of saved msgs.** - Define how many sent messages will be saved to the Sent items folder at a time. The default limit is 20 messages. When the limit is reached, the oldest message is deleted.

Profiles

To adjust and customise the tones for different events, environments, or caller groups, press  and select **Tools**→ **Profiles**. You can see the currently selected profile at the top of the display in standby mode. If the General profile is in use, only the current date is shown.

Changing the profile

- 1 Press  and select **Tools**→ **Profiles**. A list of profiles opens.
- 2 In the Profiles list, scroll to a profile and select **Options**→ **Activate**.



Note: Incoming phone calls will sound a ringing tone if set to ring in the profile settings.

Offline profile - lets you use the game deck without connecting to the GSM wireless network.



Warning: In Offline profile you cannot make (or receive) any calls, including emergency calls, or use other features that require network coverage. To make any calls, you must first activate the phone function by changing the profile. If the device has been locked, you must enter the unlock code before you can activate the phone function and make any emergency calls.



Warning: Your device must be switched on to use the offline profile. Do not switch the device on when wireless device use is prohibited or when it may cause interference or danger.

When you activate the Offline profile, the game deck restarts and the GSM is turned off, as indicated by  in the signal strength indicator. See Fig. 16. All GSM wireless phone signals to and from the device are prevented.

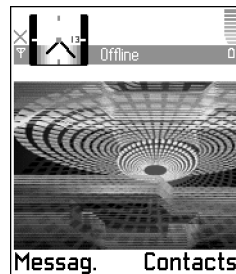





Fig. 16 Offline profile is active.





Shortcut: To change the profile, press  in standby mode. Scroll to the profile you want to activate and press **OK**.

 **Tip!** When you scroll through the ringing tone list, you can stop on a tone to listen to it before you make your selection. Press any key to stop the sound.

 **Tip!** You can change ringing tones in two places: Profiles or Contacts. See 'Adding a ringing tone for a contact card or group', p. 47.

To leave the **Offline profile**, select some other profile and select **Options**→**Activate**. Press **Yes**. The game deck restarts and re-enables GSM wireless transmissions (providing there is sufficient signal strength). If Bluetooth was turned off as a result of entering Offline profile you must re-enable Bluetooth manually. See 'Bluetooth settings', p. 89.

Customising profiles

- 1 To modify a profile, scroll to the profile in the Profiles list and select **Options**→**Personalise**. A list of profile settings opens.
- 2 Scroll to the setting you want to change and press  to open the choices:
 - **Ringing tone** - To set the ringing tone for voice calls, choose a ringing tone from the list. Tones stored on a memory card have the  icon next to the tone name.
 - **Incoming call alert** - When **Ascending** is selected, the ringing volume starts from level one and increases level by level to the set volume level.
 - **Ringing volume** - To set the volume level for the ringing and message alert tones.
 - **Message alert tone** - To set the tone for messages.
 - **Vibrating alert** - To set the game deck to vibrate at incoming voice calls and messages.
 - **Keypad tones** - To set the volume level for keypad tones.
 - **Warning tones** - The game deck sounds a warning tone, for example, when the battery is running out of power.
 - **Alert for** - To set the game deck to ring only upon calls from phone numbers that belong to a selected contact group. Phone calls coming from people outside the selected group will have a silent alert. The choices are All calls / (list of contact groups, if you have created them). See 'Creating contact groups', p. 49.
 - **Profile name** - To rename a profile. The General and Offline profiles cannot be renamed.



Calendar and To-do

Creating calendar entries

- 1 Press and select **Calendar**.
- 2 Select **Options**→ **New entry** and select:
 - **Meeting** to remind you of an appointment that has a specific date and time.
 - **Memo** to write a general entry for a day.
 - **Anniversary** to remind you of birthdays or special dates. Anniversary entries are repeated every year.
- 3 Fill in the fields. Use to move between fields.

Alarm - Select **On** and press to fill in the **Alarm time** and **Alarm date** fields. Alarm is shown with in the Day view. **Stopping a calendar alarm** - Press **Stop** to end the calendar alarm. If you press any other key, the alarm is set to snooze.

Repeat - Press to change the entry to be repeating (is shown in the Day view).

Repeat until - You can set an end date for the repeated entry.

Synchronisation - Private - after synchronisation the calendar entry can be seen only by you and it will not be shown to others with online access to view the calendar. **Public** - the calendar entry is shown to others who have access to view your calendar online. **None** - the calendar entry will not be copied to your PC when you synchronise. You can move calendar and to-do data from many different Nokia phones to your game deck or synchronise your calendar to a PC using the PC Suite for Nokia N-Gage QD. See the PC Suite online help.
- 4 To save the entry, press **Done**.



Tip! You can send calendar entries to a compatible phone. See the 'Messaging' chapter, and 'Sending data via Bluetooth', p. 89.



Shortcut: Press any key (-) in any calendar view. A Meeting entry is opened and the characters you keyed in are added to the **Subject** field.





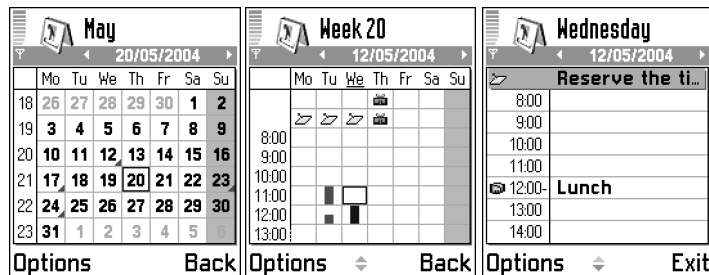

Tip! If you are editing or deleting a repeated entry, choose how you want the change to take effect: **All occurrences** - all repeated entries are deleted / **This entry only** - only the current entry will be deleted. For example, your weekly class has been cancelled. You have set the calendar to remind you every week. Choose **This entry only** and the calendar will remind you again next week.

 **Tip!** Select **Options**→**Settings** to change the view that is shown when you open the calendar or the starting day of the week.

Calendar views



In the Month view, dates that have calendar entries are marked with a small triangle at the right bottom corner. Memos and Anniversaries are placed before 8 o'clock.

- To go to a certain date, select **Options**→**Go to date**. Write the date and press **OK**.
- **Icons** in Day and Week views:  - Meeting,  - Memo, and  - Anniversary.
- Press  to jump to today.

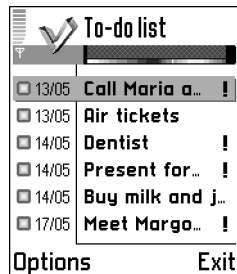







Fig. 17 Tasks in the To-do list.

To-do - Task list

- 1 Press  and select **Extras**→**To-do**.
- 2 Press any key to start to write the task in the **Subject** field.
 - To set the due date for the task, scroll to the **Due date** field and key in a date.
 - To set a priority for the to-do note, scroll to the **Priority** field and press . The priority icons are:  for **High**,  for **Low**, and no icon for **Normal**.
- 3 To save the to-do note, press **Done**.

To mark a task as completed, scroll to it and select **Options**→**Mark as done** (.

To restore a task, select **Options**→**Mark as not done** (.

Extras



Calculator

To add, subtract, multiply, and divide, press and select **Extras**→ **Calculator**.



Note: This calculator has limited accuracy and is designed for simple calculations.

- Select **MS** to save a number in the memory, indicated by **M**. To retrieve the number, select **MR**. To clear a number in memory, select **Options**→ **Memory**→ **Clear**.



Composer





To create your own, customised ringing tones, press and select **Extras**→ **Composer**. Note that it is not possible to edit a pre-installed ringing tone.















- 1 Select **Options**→ **New tone** to open the editor and to start composing. Use the keys to add notes and rests (see the table below), or select **Options**→ **Insert symbol**. The default duration for a note is 1/4.
 - To listen to the tone, select **Options**→ **Play**. To adjust the volume select **Options**→ **Volume** before you start to play the tone.
 - To adjust the tempo, select **Options**→ **Tempo**. To increase or decrease the tempo gradually, press or , respectively. Tempo is measured in beats per minute.
 - To apply different playing styles, select two or more notes and then select **Options**→ **Style**→ **Legato** - passage between successive notes is played smoothly without a break, or select one or more notes and then select **Staccato** - notes are played separately to produce short sharp sounds. Select **Natural** to remove styles.
 - To select many notes or rests at the same time, press and hold and press and hold or at the same time.

Options in Calculator: **Last result, Memory, Clear screen, Help, and Exit.**

Options in the Composer main view: **Open, New tone, Delete, Mark/Unmark, Rename, Duplicate, Help, and Exit.**

Options when composing: **Play, Insert symbol, Style, Tempo, Volume, Help, and Exit.**

- To move note(s) up or down on the staff by a half step, scroll to the note and press  or .
 - To produce C#, press and hold  together with .
- 2 Press **Back** to save the tone.

Key	Note	Key and function
	c	 Shortens the duration of the selected note(s)/rest(s) in steps.
	d	 Lengthens the duration of the selected note(s)/rest(s) in steps.
	e	 Inserts a rest.
	f	Press  to open a list of notes and rests.
	g	 Switches octaves, all selected note(s) or rest(s) is/are moved to the next octave.
	a	 Deletes selected note(s).
	b	A long press of  -  produces a lengthened (dotted) note or rest or shortens a lengthened note.





Converter - Converting measures



Options in Converter:
Select unit / Change currency, Conversion type, Currency rates, Help, and Exit.

To convert measures such as **Length** from one unit (**Yards**) to another (**Metres**), press  and select **Extras**→ **Converter**.



Note: The Converter has limited accuracy and rounding errors may occur.

- 1 Scroll to the **Type** field and press  to open a list of measures. Scroll to the measure you want to use and press **OK**.
- 2 Scroll to the first **Unit** field and press . Select the unit **from** which you want to convert and press **OK**. Scroll to the next **Unit** field and select the unit **to** which you want to convert.

- 3 Scroll to the first **Amount** field and key in the value you want to convert. The other **Amount** field changes automatically to show the converted value. Press  to add a decimal and press  for the +, - (for temperature), and E (exponent) symbols.

Setting a base currency and exchange rates

Before you can make currency conversions, you need to choose a base currency and add exchange rates. The rate of the base currency is always 1. The base currency determines the conversion rates of the other currencies.

- 1 Select **Currency** as the measure type and select **Options**→**Currency rates**. A list of currencies opens and you can see the current base currency at the top.
- 2 To change the base currency, scroll to the currency, and select **Options**→**Set as base curr..**



Note: When you change base currency, you must key in the new rates because all previously set exchange rates are set to zero.

- 3 Add exchange rates. Scroll to the currency, and key in a new rate, that is, how many units of the currency equal one unit of the base currency you have selected.
- 4 After you have inserted all the needed exchange rates, you can make currency conversions.



Tip! To change the conversion order, write the value in the second Amount field. The result is shown in the first Amount field.





Tip! To rename a currency, go to the Currency rates view, scroll to the currency, and select **Options**→**Rename currency**.



Notes

Press  and select **Extras**→**Notes**. You can link notes to Favourites and send them to other compatible devices. Plain text files (TXT format) that you receive can be saved to Notes.

- Press  -  to start to write. Press  to clear letters. Press **Done** to save.



Clock

Options in Clock: **Set alarm, Reset alarm, Remove alarm, Settings, Help, and Exit.**

Press  and select **Extras**→ **Clock**. To change the time or date, select **Options**→ **Settings** in Clock. To change the clock shown in standby mode, scroll down in the **Date and time** settings and select **Clock type**→ **Analogue** or **Digital**.

Setting an alarm

- 1 To set a new alarm, select **Options**→ **Set alarm**.
- 2 Enter the alarm time and press **OK**. When the alarm is active, the  indicator is shown.
 - To cancel an alarm, go to clock and select **Options**→ **Remove alarm**.

Turning off the alarm

- Press **Stop** to turn off the alarm.
- When the alarm tone sounds, press any key or **Snooze** to stop the alarm for five minutes, after which it will resume. You can do this a maximum of five times.

If the alarm time is reached while the device is switched off, the device switches itself on and starts sounding the alarm tone. If you press **Stop**, the device asks whether you want to activate the device for calls. Press **No** to switch off the device or **Yes** to make and receive calls. Do not press **Yes** when wireless phone use may cause interference or danger.









Recorder

Options in Recorder: **Open, Record sound clip, Delete, Move to device mem / Move to mem. card, Mark/Unmark, Rename sound clip, Send, Add to 'Go to', Settings, Help, and Exit.**

Press  and select **Extras**→ **Voice recorder**. You can record telephone conversations and voice memos, and listen to your recordings. If you are recording a telephone conversation, both parties will hear a tone every five seconds during recording.

Recorder cannot be used when a data call or GPRS connection is active.

- Select **Options**→ **Record sound clip** or **Open**. Scroll to a function and press  to select it. Use:  - to record,  - to pause,  - to stop,  - to fast forward,  - to rewind, or  - to play an opened sound file.

Go to

To store shortcuts, links to your favourite images, notes, bookmarks, and so on, press  and select **Extras**→ **Go to**.

Adding shortcuts



Shortcuts can be added only from the individual applications, like **Images**. Not all applications have this functionality.

- 1 Open an application.
- 2 Select the item to which you want to add a shortcut.
- 3 Select **Options**→ **Add to 'Go to'**.



Note: A shortcut in Favourites is automatically updated if you move the item it is pointing to, for example, from one folder to another.

Default shortcuts:

-  opens **Notes**
-  opens **Calendar**
-  opens **Inbox**

Options in Favourites:
Open, **Edit shortcut name**, **Shortcut icon**, **Delete shortcut**, **Move**, **List view / Grid view**, **Help**, and **Exit**.



Web

Various service providers maintain pages specifically designed for mobile devices. To access these pages, press  and select **Web**. These pages use the Wireless Markup Language (WML) or Extensible Hypertext Markup Language (XHTML). Pages using the Hypertext Markup Language (HTML) cannot be viewed on your device.

Check the availability of services, pricing, and tariffs with your network operator and/or service provider. Service providers will also give you instructions on how to use their services.

Basic steps for accessing Web

- Save the settings that are needed to access the Web page that you want to use. See the sections 'Receiving settings in a text message' and 'Keying in the settings manually'.
- Make a connection to Web. See 'Making a connection', p. 81.
- Start browsing the pages. See 'Browsing', p. 82.
- End the connection to Web. See 'Ending a connection', p. 82.

Receiving settings in a text message

 **Tip!** Settings may be available, for example, on the web site of a network operator or service provider.

You may receive Web service settings in a special text message from the network operator or service provider that offers the Web page. See 'Receiving logos, tones, business cards, calendar entries, and settings', p. 60. For more information, contact your network operator or service provider.

Keying in the settings manually

Follow the instructions given to you by your service provider.

- 1 Go to **Tools**→**Settings**→**Connection**→**Access points** and define the settings for an access point. See 'Connection settings', p. 36.
- 2 Go to **Web**→**Options**→**Add bookmark**. Write a name for the bookmark and the address of the page defined for the current access point.

Bookmarks view



Glossary: A bookmark consists of an Internet address (mandatory), bookmark title, access point, and if the Web page requires, a user name and password.



Note: Your device may have some bookmarks loaded for sites not affiliated with Nokia. Nokia does not warrant or endorse these sites. If you choose to access them, you should take the same precautions, for security or content, as you would with any Internet site.



The starting page defined for the access point. If you use another access point for browsing, the starting page is changed accordingly.



The last visited page. When the device is disconnected from Web, the address of the last visited page is kept in memory until a new page is visited during the next connection.



Any bookmark showing the title or Internet address of the bookmark.

Making a connection

Once you have stored all the required connection settings, you can access the pages.

Select a page or a bookmark, or write the address, press  to start to download the page.

Connection security

If the security indicator  is displayed during a connection, the data transmission between the device and the internet gateway or server is encrypted.



Options in the Bookmarks view: **Open, Download, Back to page, Send, Go to web address / Find bookmark, Add bookmark, Edit, Delete, Read service msgs., Disconnect, Move to folder, New folder, Mark/Unmark, Rename, Clear cache, Details, Add to 'Go to', Settings, Help and Exit.**



Shortcut: To start a connection, press and hold  in standby mode.



Tip! To send a bookmark, scroll to it and select **Options**→**Send**→**Via text message.**

Options when browsing: **Open**, **Service options**, **Bookmarks**, **History**, **Go to web address**, **View image**, **Read service msgs.**, **Save as bookmark**, **Send bookmark**, **Reload**, **Disconnect**, **Show images**, **Clear cache**, **Save page**, **Find**, **Details**, **Session**, **Security**, **Settings**, **Help**, and **Exit**.





Tip! To access the Bookmarks view while browsing, press and hold down . To return to the browser view again, select **Options**→ **Back to page**.



Note: The security icon does not indicate that the data transmission between the gateway and the content server (or place where the requested resource is stored) is secure. The service provider secures the data transmission between the gateway and the content server.

Browsing

- To go to the previous page while browsing, press **Back**. If **Back** is not available, select **Options**→ **History** to view a chronological list of the pages you have visited during a browsing session. The history list is cleared each time a session is closed.
- To retrieve the latest content from the server, select **Options**→ **Reload**.
- To save a bookmark, select **Options**→ **Save as bookmark**.
To save a page, while browsing select **Options**→ **Save page**. You can save pages either to the game deck's memory or on a memory card and browse them when offline. To access the pages later, press  in the Bookmarks view.
- To open a sublist of commands or actions for the currently open page, select **Options**→ **Service options**.
- You can download items such as ringing tones, images, operator logos and video clips. Downloaded items are saved in their respective applications on your game deck, for example, a downloaded image is saved in **Images**.
 **Important:** Only install software from sources that offer adequate protection against harmful software.
- To download and view new service messages while browsing, select **Options**→ **Read service msgs.** (shown only if there are new messages). See also 'Receiving service messages', p. 61.

Ending a connection

Select **Options**→ **Disconnect**, or press and hold  to quit browsing and to return to standby mode.

Emptying the cache

The information or services you have accessed are stored in the cache memory of the game deck.

A cache is a memory location that is used to store data temporarily. If you have tried to access or have accessed confidential information requiring passwords, empty the cache after each use. The information or services you have accessed is stored in the cache. To empty the cache, select **Options**→ **Clear cache**.

Settings for Web

Select **Options**→ **Settings**:



- **Default access point** - To change the default access point, press to open a list of available access points. See 'Connection settings', p. 36.
- **Show images** - If you choose **No**, you can later load images during browsing by selecting **Options**→ **Show images**.
- **Text wrapping** - Choose **Off** if you don't want the text in a paragraph to automatically wrap, or **On** if you do.
- **Font size** - Choose text size.
- **Cookies** - Enable or disable the receiving and sending of cookies.
- **Default encoding** - To make sure your browser pages display text characters correctly, select the appropriate language type.
- **Conf. DTMF sending** - Choose whether you want to confirm before the game deck sends DTMF tones during a voice call. See also 'DTMF tones', p. 28.

Applications and Manager

Notes on installing applications and software

You can install two types of applications and software to your game deck:

- **J2ME™ applications based on Java™ technology** with the extension .JAD or .JAR are installed in Applications. Do not download PersonalJava™ applications to your game deck as they cannot be installed. See 'Applications (Java™)', p. 85.
- **Other applications and software** specifically intended for the N-Gage game deck or suitable for the Symbian operating system are installed in **Manager**. The installation files have the extension .SIS. See 'Manager - Installing and removing software', p. 86.

 **Example:** If you have received the installation file as an e-mail attachment, go to your mailbox, open the e-mail, open the Attachments view, scroll to the installation file, and press  to start installation.

Installation files may be transferred to your game deck from a compatible computer, downloaded during browsing, or sent to you in a multimedia message, as an e-mail attachment, or via Bluetooth. If you are using PC Suite for Nokia N-Gage QD to transfer a file, place the file in the **Installation and Java files (C:\NOKIAINSTALLS)** folder in your game deck or on a memory card. If you are using Microsoft Windows Explorer to transfer a file, place the file on a memory card (local disk).





Important: Only install applications from sources that offer adequate protection against harmful software.

During installation, the game deck shows information about the progress of the installation. If you are installing an application without a digital signature or certification, the game deck displays a warning. Continue installation only if you are sure of the origins and content of the application.

Applications (Java™)

Installing an application

- 1 Press  and select **Extras**→**Applications**. Press  to open the **Downloaded** view with a list of Java installation files saved in the **c:\nokia\installs** folder in your game deck.
- 2 Scroll to an installation file and select **Options**→**Install**.
- 3 When the game deck asks whether to install or update the application, press **Yes** to proceed with installation.
The .JAR file is required for installation. If it is missing, the game deck may ask you to download it. If there is no access point defined for Applications, you will be asked to select one. When you are downloading the JAR file, you may need to enter a user name and password to access the server. You obtain these from the supplier or manufacturer of the application.
- 4 The game deck informs you when installation is complete.

Applications main view

- To start an application, scroll to it and press .
- To uninstall an application, scroll to it and select **Options**→**Remove**.
- To start a network connection and to check if there is an update available for the application, scroll to it and select **Options**→**Update**.
- To start a network connection and to view extra information about the application, scroll to it and select **Options**→**Go to URL address**, if available.
- To view information such as the type, version number and the supplier or manufacturer of an application, scroll to it and select **Options**→**View details**.

Options in the **Downloaded** view: **Install, Delete, View details, Settings, Help, and Exit.**



Tip! While browsing, you can download an installation file and install it without closing the connection.

Options in the **Applications main view**: **Open, Remove, Update, Go to URL address, View details, Settings, Help, and Exit.**

Applications settings

To define a default access point for downloading applications and application components, go to the **Downloaded** view and select **Options**→**Settings**→**Default access point**.

Some Java applications may require a network connection to be made to a specific access point for downloading extra data or components. In the Applications main view, scroll to an application and select **Options**→**Settings**→**Settings**, and then select:

- **Access point** to select an access point to be used by the application. See the 'Access points', p 37.
- **Network connection** - The options are:
 - **Allowed** - Connections for the application are allowed without a notification.
 - **Ask first** - You will be asked before the application makes a connection.
 - **Not allowed** - Connections for the application are not allowed.





Manager - Installing and removing software



Options in the Manager main view: **View details**, **View certificate**, **Install**, **Remove**, **View log**, **Send log**, **Memory details/Device memory**, **Help**, and **Exit**.

Press  and select **Tools**→**Manager** to see a list of:

- Applications and software that you can install (no indicator icon).
- Installed applications and software that you can remove, indicated by .
- Applications and software whose installation was canceled or interrupted, indicated by . You cannot use these applications. You should either remove them or try to re-install them.

Installing software



Important: Only install applications from sources that offer adequate protection against harmful software.

If you install a file that contains an update or repair to an existing application, you can only restore the original application if you have the original installation file or a full back-up copy of the removed software package. To restore the original application, first remove the application and then install the application again from the original installation file or the back-up copy.

- 1 Open Manager, scroll to an installation package, and select:
 - **Options**→ **View details** to view information such as the type, version number and the supplier or manufacturer of the application.
 - **Options**→ **View certificate** to display the security certificate details of the application. See 'Certif. management', p. 42.
- 2 Select **Options**→ **Install** to start installation.
- 3 When the game deck asks whether to install or update the application or software, press **Yes** to proceed with installation.

If the game deck displays a security warning and you choose to continue installation, you are given the option to view the details and the security certificate of the software package.

During installation, you may be able to choose the installation language and select which components of the software package you want to install.
- 4 The game deck informs you when installation is complete.

Removing software

Scroll to a software package and select **Options**→ **Remove**. Press **Yes** to confirm.

If you remove software, you can only re-install it if you have the original software package or a full back-up of the removed software package. If you remove a software package, you may no longer be able to open documents created with that software.



Note: If another software package depends on the software package that you removed, the other software package may stop working. Refer to the documentation of the installed software package for details.



Tip! Select **Options**→ **View log** to see what software packages have been installed or removed and when.



Tip! To send your installation log to a help desk so that they can see what has been installed or removed, select **Options**→ **Send log**→ **Via text message** or **Via e-mail** (available only if the correct e-mail settings are in place).

Connectivity



Bluetooth connection

Bluetooth enables wireless connections for playing games, sending images, texts, or to connect wirelessly to Bluetooth enabled devices such as computers. Since Bluetooth devices communicate using radio waves, your game deck and the other Bluetooth device do not need to be in direct line-of-sight. The two devices only need to be within a maximum of 10 metres of each other, although the connection can be subject to interference from obstructions such as walls or from other electronic devices.

This device is compliant with Bluetooth Specification 1.1 supporting the following profiles: Generic Access Profile, Service Discovery Profile, Serial Port Profile, Dial-up Networking Profile, Fax Profile, Headset Profile, Handsfree Profile, Generic Object Exchange Profile, Object Push Profile, and File Transfer Profile. To ensure interoperability between other devices supporting Bluetooth technology, use Nokia approved enhancements for this model. Check with the manufacturers of other devices to determine their compatibility with this device.

There may be restrictions on using Bluetooth technology in some locations. Check with your local authorities or service provider.

Features using Bluetooth technology, or allowing such features to run in the background while using other features, increase the demand on battery power and reduces the battery life.

Press  and select **Tools** → **Bluetooth**. You are asked to give a Bluetooth name to your device.

Bluetooth settings

- **Bluetooth – On/Off**
- **My device's visibility: Shown to all** – your game deck can be found by other Bluetooth devices or **Hidden** – your game deck cannot be found by other devices.
- **My device's name** – Define a Bluetooth name for your game deck.



Note: After you have set Bluetooth to be active and changed **My device's visibility to Shown to all**, your game deck and this name can be seen by other Bluetooth device users.

Sending data via Bluetooth

There can be only one active Bluetooth connection at a time.

- 1 Open an application where the item you wish to send is stored. For example, to send an image to another compatible device, open the Images application.
- 2 Select the item, for example, an image and select **Options**→ **Send**→ **Via Bluetooth**.
- 3 The game deck starts to search for devices within range. Bluetooth enabled devices that are within range start to appear on the display one by one. You can see a device icon, the device's Bluetooth name, the device type, or a short name.



Tip! If you have searched for Bluetooth devices earlier, a list of the devices that were found previously is shown first. To start a new search, select **More devices**. If you switch off the game deck, the list is cleared.

- To interrupt the search, press **Stop**. The device list freezes and you can start to form a connection to one of the devices already found.
- 4 Scroll to the device you want to connect with and press **Select**.
 - 5 **Pairing (if not required by the other device, see step 6)**



Glossary: Pairing means authentication. The users of the Bluetooth enabled devices should agree what the passcode is and use the same passcode for both devices in order to pair them. Devices that do not have a user interface have a factory-set passcode.

Icons for different Bluetooth devices:



Computer



Phone



Other



Unknown



Tip! When searching for devices, some Bluetooth devices may show only the unique Bluetooth addresses (device addresses). To find out what the unique Bluetooth address of your game deck is, enter the code ***#2820#** in standby mode.



 **Tip!** To send text via Bluetooth (instead of text messages), go to Notes, write the text, and select **Options**→**Send**→**via Bluetooth**.

 **Tip!** To define a short name (nickname, alias), scroll to the device and select **Options**→**Assign short name** in the Paired devices view. This name helps you to recognise a certain device during device search or when a device is requesting a connection.





- If the other device requires pairing before data can be transmitted, a tone sounds and you are asked to enter a passcode.
 - Create your own passcode (1-16 characters long, numeric) and agree with the owner of the other Bluetooth device to use the same code. The passcode is used only once.
 - After pairing, the device is saved to the Paired devices view.
- 6 When the connection has been established, the note **Sending data** is shown.

If sending fails, the message or data will be deleted. The Drafts folder in Messaging does not store messages sent via Bluetooth.

Checking the status of the Bluetooth connection

- When  is shown in standby mode, Bluetooth is active.
- When  is blinking, your game deck is trying to connect to the other device.
- When  is shown continuously, the Bluetooth connection is active.

Pairing devices

Paired devices are easier to recognise, they are indicated by  in the device search. In the Bluetooth main view, press  to open a list of paired devices   .



- **To pair with a device:** Select **Options**→**New paired device**. The game deck starts a device search. Scroll to the device and press **Select**. Exchange passcodes, see step 5 (Pairing), p. 89.
- **To cancel a pairing:** Scroll to the device and select **Options**→**Delete**. If you want to cancel all pairings, select **Options**→**Delete all**.

 **Tip!** If you are currently connected to a device and delete the pairing with that device, pairing is removed immediately but the connection will remain active.

- **To set a device to be authorised or unauthorised:** Scroll to a device and select **Options**→**Set as authorised** - Connections between your game deck and this device can be made without your knowledge. No separate acceptance or authorisation is needed. Use this status for your own devices, for example, your PC, or devices that belong to someone you trust. The icon  is added next to authorised devices in the

Paired devices view. **Set as unauthorised** - Connection requests from this device need to be accepted separately every time.

Receiving data via Bluetooth

When you receive data via Bluetooth, a tone sounds and you are asked if you want to accept the Bluetooth message. If you accept,  is shown and the item is placed in the Inbox folder in Messaging. Bluetooth messages are indicated by . See 'Inbox - receiving messages', p. 59.

Switching off Bluetooth

To switch off Bluetooth, select **Bluetooth**→ **Off**.

Connecting to a computer via Bluetooth

For further information on how to install the PC Suite for Nokia N-Gage QD, make a connection to a compatible computer via Bluetooth, and use the PC Suite for Nokia N-Gage QD, see the **PC Suite Installation Guide** on the CD-ROM in the 'Install' section and the PC suite **Help**.

Using the CD-ROM

The CD-ROM should launch itself after you have inserted it into the CD-ROM drive of a compatible PC (compatible with WinXP, Win98, WinME, Win98SE ja Win2000). If not, proceed as follows: Open Windows Explorer, right-click the CD- ROM drive where you inserted the CD- ROM, and select 'AutoPlay'.

Battery information

Charging and Discharging

Your device is powered by a rechargeable battery. The full performance of a new battery is achieved only after two or three complete charge and discharge cycles. The battery can be charged and discharged hundreds of times but it will eventually wear out. When the talk and standby times are noticeably shorter than normal, buy a new battery. Use only Nokia approved batteries, and recharge your battery only with Nokia approved chargers designated for this device.

Unplug the charger from the electrical plug and the device when not in use. Do not leave the battery connected to a charger. Overcharging may shorten its lifetime. If left unused, a fully charged battery will lose its charge over time. Temperature extremes can affect the ability of your battery to charge.

Use the battery only for its intended purpose. Never use any charger or battery that is damaged.

Do not short-circuit the battery. Accidental short-circuiting can occur when a metallic object such as a coin, clip, or pen causes direct connection of the positive (+) and negative (-) terminals of the battery. (These look like metal strips on the battery.) This might happen, for example, when you carry a spare battery in your pocket or purse. Short-circuiting the terminals may damage the battery or the connecting object.

Leaving the battery in hot or cold places, such as in a closed car in summer or winter conditions, will reduce the capacity and lifetime of the battery. Always try to keep the battery between 15°C and 25°C (59°F and 77°F). A device with a hot

or cold battery may not work temporarily, even when the battery is fully charged. Battery performance is particularly limited in temperatures well below freezing.

Do not dispose of batteries in a fire! Dispose of batteries according to local regulations. Please recycle when possible. Do not dispose as household waste.

CARE AND MAINTENANCE

Your device is a product of superior design and craftsmanship and should be treated with care. The suggestions below will help you protect your warranty coverage.

- Keep the device dry. Precipitation, humidity and all types of liquids or moisture can contain minerals that will corrode electronic circuits. If your device does get wet, remove the battery and allow the device to dry completely before replacing it.
- Do not use or store the device in dusty, dirty areas. Its moving parts and electronic components can be damaged.
- Do not store the device in hot areas. High temperatures can shorten the life of electronic devices, damage batteries, and warp or melt certain plastics.
- Do not store the device in cold areas. When the device returns to its normal temperature, moisture can form inside the device and damage electronic circuit boards.
- Do not attempt to open the device other than as instructed in this guide.

- Do not drop, knock, or shake the device. Rough handling can break internal circuit boards and fine mechanics.
- Do not use harsh chemicals, cleaning solvents, or strong detergents to clean the device.
- Do not paint the device. Paint can clog the moving parts and prevent proper operation.
- Use only the supplied or an approved replacement antenna. Unauthorised antennas, modifications, or attachments could damage the device and may violate regulations governing radio devices.

All of the above suggestions apply equally to your device, battery, charger, or any enhancement. If any device is not working properly, take it to the nearest authorized service facility for service.

ADDITIONAL SAFETY INFORMATION

Operating environment

Remember to follow any special regulations in force in any area and always switch off your device when its use is prohibited or when it may cause interference or danger. Use the device only in its normal operating positions. To maintain compliance with radio frequency exposure guidelines only use enhancements approved by Nokia for use with this device. When the device is on and being worn on the body, always use an approved holder or carrying case.

Medical devices

Operation of any radio transmitting equipment, including wireless phones, may interfere with the functionality of

inadequately protected medical devices. Consult a physician or the manufacturer of the medical device to determine if they are adequately shielded from external RF energy or if you have any questions. Switch off your device in health care facilities when any regulations posted in these areas instruct you to do so. Hospitals or health care facilities may be using equipment that could be sensitive to external RF energy.

Pacemakers Pacemaker manufacturers recommend that a minimum separation of 6 in. (15.3 cm) be maintained between a wireless phone and a pacemaker to avoid potential interference with the pacemaker. These recommendations are consistent with the independent research by and recommendations of Wireless Technology Research. Persons with pacemakers should:

- always keep the device more than 6 in. (15.3 cm) from their pacemaker when the device is switched on;
- not carry the device in a breast pocket; and
- hold the device to the ear opposite the pacemaker to minimise the potential for interference.

If you have any reason to suspect that interference is taking place, switch off your device immediately.

Hearing aids Some digital wireless devices may interfere with some hearing aids. If interference occurs, consult your service provider.

Vehicles

RF signals may affect improperly installed or inadequately shielded electronic systems in motor vehicles such as electronic fuel injection systems, electronic antiskid (antilock) braking systems, electronic speed control systems, air bag

systems. For more information, check with the manufacturer or its representative of your vehicle or any equipment that has been added.

Only qualified personnel should service the device, or install the device in a vehicle. Faulty installation or service may be dangerous and may invalidate any warranty that may apply to the device. Check regularly that all wireless device equipment in your vehicle is mounted and operating properly. Do not store or carry flammable liquids, gases, or explosive materials in the same compartment as the device, its parts, or enhancements. For vehicles equipped with an air bag, remember that air bags inflate with great force. Do not place objects, including installed or portable wireless equipment in the area over the air bag or in the air bag deployment area. If in-vehicle wireless equipment is improperly installed and the air bag inflates, serious injury could result.

Using your device while flying in aircraft is prohibited. Switch off your device before boarding an aircraft. The use of wireless teledevices in an aircraft may be dangerous to the operation of the aircraft, disrupt the wireless telephone network, and may be illegal.

Potentially explosive environments

Switch off your device when in any area with a potentially explosive atmosphere and obey all signs and instructions. Potentially explosive atmospheres include areas where you would normally be advised to turn off your vehicle engine. Sparks in such areas could cause an explosion or fire resulting in bodily injury or even death. Switch off the device at refuelling points such as near gas pumps at service stations. Observe restrictions on the use of radio equipment in fuel

depots, storage, and distribution areas, chemical plants or where blasting operations are in progress. Areas with a potentially explosive atmosphere are often but not always clearly marked. They include below deck on boats, chemical transfer or storage facilities, vehicles using liquefied petroleum gas (such as propane or butane), and areas where the air contains chemicals or particles such as grain, dust or metal powders.

Safety information about video games

About photosensitive seizures A very small percentage of people may experience a seizure when exposed to certain visual images, including flashing lights or patterns that may appear in video games. Even people who have no history of seizures or epilepsy may have an undiagnosed condition that can cause photosensitive epileptic seizures while watching video games. These seizures may have a variety of symptoms, including lightheadedness, altered vision, eye or face twitching, jerking or shaking of arms or legs, disorientation, confusion, or momentary loss of awareness. Seizures may also cause loss of consciousness or convulsions that can lead to injury from falling down or striking nearby objects.

Immediately stop playing and consult a doctor if you experience any of these symptoms. Adults who allow teenagers (or children) to play the games should watch for or ask their children about these symptoms as they are more likely than adults to experience these seizures. The risk of photosensitive epileptic seizures may be reduced by playing in a well-lit room and by not playing when you are drowsy or fatigued. If you or any of your relatives have a history of seizures or epilepsy, consult a doctor before playing.

Play safely Take a break from playing games at least every half hour. Stop playing immediately if you begin to feel tired or if you experience an unpleasant sensation or pain in your hands and/or arms. If the condition persists, consult a doctor.

Use of vibration can aggravate injuries. Do not turn vibration on if you have any ailment in the bones or joints of your fingers, hands, wrists, or arms.



Emergency calls



Important: Wireless phones, including this device, operate using radio signals, wireless networks, landline networks, and user-programmed functions. Because of this, connections in all conditions cannot be guaranteed. You should never rely solely on any wireless device for essential communications like medical emergencies.

To make an emergency call: 1 If the device is not on, switch it on. Check for adequate signal strength.

Some networks may require that a valid SIM card is properly inserted in the device.

- 2 Press  as many times as needed to clear the display and ready the device for calls.
- 3 Key in the official emergency number for your present location. Emergency numbers vary by location.
- 4 Press the  key.

If certain features are in use, you may first need to turn those features off before you can make an emergency call. If the device is in an offline or flight mode you must change the profile to activate the phone function before you can make an

emergency call. Consult this guide or your service provider for more information.

When making an emergency call, give all the necessary information as accurately as possible. Your wireless device may be the only means of communication at the scene of an accident. Do not end the call until given permission to do so.



WARNING! In Offline profile you cannot make (or receive) any calls, including emergency calls, or use other features that require network coverage.

Certification information (SAR)

THIS DEVICE MEETS INTERNATIONAL GUIDELINES FOR EXPOSURE TO RADIO WAVES

Your mobile device is a radio transmitter and receiver. It is designed and manufactured not to exceed the limits for exposure to radio frequency (RF) recommended by international guidelines (ICNIRP). These limits are part of comprehensive guidelines and establish permitted levels of RF energy for the general population. The guidelines were developed by independent scientific organisations through periodic and thorough evaluation of scientific studies. The guidelines include a substantial safety margin designed to assure the safety of all persons, regardless of age and health.

The exposure standard for mobile devices employs a unit of measurement known as the Specific Absorption Rate, or SAR. The SAR limit stated in the international guidelines is 2.0 W/kg*. Tests for SAR are conducted using standard operating positions with the device transmitting at its highest certified power level in all tested frequency bands. Although the SAR is determined at the highest certified power level, the actual

SAR of the device while operating can be well below the maximum value. This is because the device is designed to operate at multiple power levels so as to use only the power required to reach the network. In general, the closer you are to a base station, the lower the power output of the device.

The highest SAR value for this device when tested for use at the ear is 0.57 W/kg.

This device meets RF exposure guidelines when used either in the normal use position against the ear or when positioned at least 2.2 cm away from the body. When a carry case, belt clip or holder is used for body-worn operation, it should not contain metal and should position the product at least 2.2 cm away from your body.

In order to transmit data files or messages, this device requires a quality connection to the network. In some cases, transmission of data files or messages may be delayed until such a connection is available. Ensure the above separation distance instructions are followed until the transmission is completed.

* The SAR limit for mobile devices used by the public is 2.0 watts/kilogram (W/kg) averaged over ten grams of body tissue. The guidelines incorporate a substantial margin of safety to give additional protection for the public and to account for any variations in measurements. SAR values may vary depending on national reporting requirements and the network band. For SAR information in other regions please look under product information at www.nokia.com.

Index

A

- Access codes 41
- Access points 36
 - Settings 37
 - Settings, Advanced 39
- Alarms

- Alarm clock 78
- Calendar alarms 73

- Applications, Java 84, 85

B

Bluetooth

- Connection requests 90
- Connection status indicators 90
- Device address 89
- Device icons 89
- Factory set passcode 89
- Pairing 89
- Pairing requests 90
- Pairing, glossary explanation 89
- Passcode, glossary explanation 89
- Switching off 91

- Bookmark, glossary explanation 81

C

- Cache 83
- Calendar
 - Alarm 73

- Sending entries 73
- Stopping a calendar alarm 73
- Using PC Suite 73

Call register

- See *Log*

Calls

- Cost limit 30
- Dialled numbers 29
- Duration 30
- International 26
- Received 29
- Settings 34
- Settings for call divert 29
- Transferring 28

CD-ROM 91

Cell broadcast messages

Certificates 42

Changing between applications 18

Clear screen

- See *Standby mode*

Clock

- Alarm 78
- Settings 78
- Snooze 78
- Computer connections 91
- Connection indicators
 - Bluetooth 90

GPRS 21

- GSM data call 21

Connection settings 36

Contact cards

- Inserting pictures 46
- Removing ringing tones 47
- Storing DTMF tones 28

Copying

- Contacts between the SIM card and device memory 47
- Text 56

Cutting

- Text 56

D

Data connections

- Indicators 21

Date

- Settings 40

DNS, Domain Name Service, glossary explanation 39

E

E-mail 57

- Offline 63
- Opening 62
- Remote mailbox 61
- Retrieving from mailbox 62

Viewing attachments 62

F

File formats

SIS file 84

Fixed dialling 42

G

Game card 13

Games

Deleting game data 16

Managing game data 15

Multiple players 15

Offline profile 71

Starting a game 15

GPRS 36

Data counter 32

Glossary explanation 36

Settings 39

H

Handsfree

See *Loudspeaker*

Help 16, 18

I

Idle state

See *Standby mode*

Images

Adding to a contact card 46

Indicators and icons in standby mode 21

Info service

See *Cell broadcast messages*.

Internet access points (IAP)

See *Access points*

IP address, glossary explanation 39

ISDN, glossary explanation 38

J

Java

See *Applications*.

L

Lock code 41

Log

Erasing contents 31

Filtering 31

Loudspeaker 25

Activating 25

Turning off 25

M

Mailbox 61

Memory card 13, 23

Password 24

Unlocking 25

Memory low

Viewing memory consumption 22

Menu

Rearranging 20

Messaging

Multimedia messages 57

Writing e-mail 57

Multimedia messages 57

Playing sounds 59

Re-playing sounds 59

P

Pasting

Text 56

PC

Connecting 91

PC Suite

Calendar data 73

Pictures

Viewing 50

PIN code 41

Prepaid SIM cards 30

R

Recording voice tags 48

Reminder

See *Calendar, Alarm*

Remote mailbox 61

Ringling tones

Adding a personal ringling tone 47

Receiving in a text message 60

Settings 71

S

Sending

Contact cards, Business cards 47

Settings

Access codes 41

Access points 37

Applications (Java™) 86

Bluetooth 89

- Calendar 74
- Call barring 44
- Call diverting 29
- Certificates 42
- Data connections 36
- Date and time 40
- Display 34
- Language 33
- Lock code 41
- Log 32
- Original settings 34
- Personalising the game deck
- PIN code 41
- Screen saver 34
- Sounds 71
- Short message service centre 65
- Shortcuts
 - in Favourites 79
 - in Images 50
 - in Standby mode 20
- SIM card
 - Copying names and numbers 47
 - Messages 64
 - Messages on SIM 32
 - Names and numbers 32
- SIS file 84
- SMS centre 65
- Snooze
 - Alarm clock 78
 - Calendar alarm 73

- Software
 - Transferring a .SIS file to your device 84
- Sounds
 - Muting a ringing tone 28
 - Recording sounds 78
 - Removing a personal ringing tone 47
 - Settings 71
- Speed dialling 27
- Standby mode 20
- T**
 - Text message service centre
 - Adding new 65
 - Thumbnails
 - In a contact card 46
 - Time
 - Settings 40
- U**
 - USSD commands 65
- V**
 - Video recorder 51
 - Viewing images 50
 - Voice dialling 47
 - Voice mailbox 26
 - Diverting calls to voice mailbox 29
 - Voice messages 26
 - Voice tags 47
 - Adding 48

- Making calls 48
- Volume control 25
 - During a call 26
 - Loudspeaker 25
- W**
 - Web
 - Access points, see *Access points*