

TOSHIBA

Leading Innovation >>>

User guide

TG01

 Windows® phone



Table of contents

Preface 5

Declaration of conformity 6

Health and safety 7

General 7

Operating environment 8

Electronic devices 9

Battery safety 10

AC charger safety 11

Emergency calls 11

FCC notice 12

Information to user 12

FCC RF exposure information 13

European RF Exposure

Information 15

Disposal 16

Care and maintenance 18

General 18

Battery care and maintenance 20

Restarting your Toshiba phone 21

Resetting your Toshiba phone 22

Reinitialising your Toshiba phone 22

Getting started 23

Unpacking 23

Phone layout and functions 24

Installing the SIM card, microSD card
and battery 27

Using the stylus 31

Charging the battery 32

Switching the power on and off 33

Selecting the Home Screen 34

Toshiba Touch user interface 34

Operator Settings 40

Synchronising your Toshiba phone
with a PC 40

Table of contents

Call functions 43

- Receiving a call 43
- Ending a call 43
- Making a call 44
- Speed Dial 45
- In-call options 46
- Multiple and multiparty calls 47
- Call History 49

Messaging 50

- Text messages 50
- MMS messages 52
- E-mail 55

Applications and multimedia 58

- Office Mobile 58
- Calendar 59
- Contacts 61
- Internet Explorer 64
- Games 65

- Camera 66
- CorePlayer 68
- File Explorer 68
- Getting Started 68
- Java 68
- Marketplace 69
- Microsoft My Phone 69
- Notes 70
- PhotoBase 70
- Pictures & Videos 71
- Search Phone 71
- SIM Toolkit 72
- Tasks 72
- Video Editor 73
- Windows Live 73
- Windows Media 74

Table of contents

Connectivity 76

- Wireless Manager 76
- Bluetooth 76
- Beam 79
- Internet connections 80
- Domain Enroll 80
- Internet Sharing 80
- USB to PC 81
- Wi-Fi 81

Settings 82

- Volume control 82
- Location Request 82
- Security settings 83
- Customising the Toshiba Menu 86
- Owner Information 86
- Phone settings 87
- Sounds & Notifications 92
- About 93
- Adjust Motion Sensor 94

- Backlight settings 94
- Browser Settings 95
- Certificates 95
- Clock & Alarms 95
- Customer Feedback 96
- Encryption 96
- Error Reporting 97
- External GPS 97
- Free Pad Settings 98
- Internal GPS 98
- Managed Programs 98
- Master Clear 99
- Memory management 100
- Motion Sensor Settings 100
- Power settings 100
- Power Saving Settings 100
- Regional Settings 101
- Remove Programs 101
- Screen settings 102
- Task Manager 103

Table of contents

Video Quality Setting 103
Sleep Mode Indicator 103
Operator Name Setting 103

Specifications 104

Troubleshooting 107

Annex 1 - Text input 111

Input methods 111
Input Panel 111
Writing and drawing on the screen 115

Annex 2 - Navigating your Toshiba phone 117

Phone screen 117
Accessing applications and settings 118

Annex 3 - Common status icons 123

Annex 4 - Configuring SMS, MMS and e-mail 126

Setting up text messages service centre 126
Configuring MMS settings 126
Setting up e-mail accounts 127
General messaging options 132

Annex 5 - Configuring internet settings 134

Toshiba Corporation 139

End User License Agreements (EULAs) 141

Licenses 147

Index 149

Preface

Hello and welcome

Congratulations on your purchase of the Toshiba TG01.

For additional phone content, please visit www.toshiba-europe.com/mobile.

If you require further technical support please contact our customer operations team as follows:

Tel.: 008000 505 2006

E-mail: customer_operations@toshiba.co.uk

Opening hours: Monday - Friday 9AM - 1PM and 2PM - 6PM (CET)

We hope you enjoy using your new Toshiba phone.

To use your Toshiba phone, you must have service from a wireless service provider. Many of the features in your Toshiba phone depend on features in the wireless network to function. These network services may not be available on all networks, or you may have to make specific arrangements with your service provider before you can utilise network services. Your service provider may need to give you additional instructions for their use and explain what charges will apply. Some networks may have limitations that affect how you can use network services. For instance, some networks may not support all language-dependent characters and services.

The availability of particular products may vary by region.

Due to the continual development of our products, Toshiba reserves the right to modify this document at any time without prior notice.

Declaration of conformity

We, **Toshiba Information Systems UK (Ltd), Mobile Communications Division, of Toshiba Court, Weybridge Business Park, Addlestone Road, Weybridge, KT15 2UL** declare under our sole responsibility that this product (TG01, Type (Model) Name TM5-E01) is in conformity with the following standards and/or other normative documents:

EN 301 511, EN 301 908-1, EN 301 908-2, EN 60950-1, EN 300 328, EN 300 440, EN 50360, EN 62209-1, EN 301 489-1, EN 301 489-3, EN 301 489-7, EN 301 489-17, and EN 301 489-24

We hereby declare that all essential radio test suites, EMC & safety requirements have been carried out and that the above named product is in conformity to all the essential requirements of Directive 1999/5/EC.

The conformity assessment procedure referred to in Article 10(5) and detailed in Annex IV of Directive 1999/5/EC has been followed with the involvement of the following Notified Body(ies):

Cetecom GmbH, Im Teelbruch 116, 45219 Essen, Germany

C € 0682 !

1 August 2009



Hidehito Koka
Deputy Managing Director of TIU
General Manager Mobile Communications Division

Health and safety

General

- Do not attempt to dismantle the phone or any of its accessories. Only qualified service personnel should repair the phone and its accessories.
- Do not touch the phone, battery or AC charger with wet hands.
- Keep your Toshiba phone, and all parts and accessories, out of the reach of small children and pets. The SIM card and other small parts could present a choking hazard.
- Use only Toshiba approved batteries and accessories.
- The bundled battery and AC charger are only for use with your Toshiba phone. Do not use this battery or AC charger with any other device.
- Use of third party equipment (including batteries, cables and accessories) not manufactured or authorised by Toshiba may invalidate the warranty of your phone and adversely affect the operation of the phone.
- Before connecting your Toshiba phone to another device, read the supporting documentation to confirm that the other device is compatible.
- When using the headset, be careful not to listen at excessive volumes. Listening to loud sound levels may lead to hearing loss.
- It is recommended that pregnant and young women take precautions while in a call and keep the phone at a distance from their lower abdomen. For this situation, use of a hands-free kit is recommended.
- Your phone contains metal that may cause skin irritation.

Health and safety

Operating environment

- Observe all local safety regulations regarding the use of mobile phones while driving.
- Pull off the road and park before making or answering a call.
- Do not stop on the hard shoulder of a motorway to answer or make a call, except in an emergency.
- If using an integrated hands-free device, make sure the phone is securely placed in its holder.
- Only qualified personnel should install the device in a vehicle. Faulty installation or service may be dangerous and may invalidate any warranty. For more information, consult your vehicle manufacturer or representative.
- Do not place objects, including either installed or portable wireless equipment, in the area over the airbag or in the airbag deployment area.
- Switch off your Toshiba phone when refuelling.
- Do not handle your Toshiba phone when operating machinery.
- Switch your Toshiba phone off if you are entering a hospital or health care facility. Medical equipment may be affected by phone usage.
- Switch your Toshiba phone off when travelling on an aircraft. The phone signal may interfere with systems in the aircraft. You are legally bound to comply with this recommendation.
- Switch your Toshiba phone off in any facility where posted notices prohibit phone usage. Always follow building regulations governing phone usage.
- Switch your Toshiba phone off when blasting is in progress, and observe all provided guidelines and regulations.
- Switch your Toshiba phone off in areas with potentially explosive atmospheres, such as fuel storage areas and spray paint facilities.
- Switch your Toshiba phone off when outdoors during an electrical storm.

Health and safety

- Keep your Toshiba phone away from fuel and chemicals.

Electronic devices

- If you wear a pacemaker, or are in the company of someone who does, you should be aware that there is a small risk of mobile phone usage interfering with the operation of the pacemaker. You should contact your doctor, or the manufacturer of the pacemaker, for more information. If you have any reason to suspect that interference is taking place, switch off your phone immediately.
- Mobile phone usage may interfere with some hearing aids. If this happens, you should contact your service provider or doctor for further information.
- Mobile phone usage may interfere with the functionality of inadequately shielded medical devices. Consult a physician or the manufacturer of the device to ensure safe procedures are used.

- Mobile phone usage may interfere with the functionality of any inadequately shielded electronic system in a motor vehicle. Examples include airbags and fuel injection systems. You should contact the manufacturer of the vehicle or system to ensure that the system is properly shielded.

Health and safety

Battery safety

- Only use batteries approved by Toshiba for use in this handset. There is a risk of explosion if the battery is replaced with an incorrect type.
- Only recharge the battery with the recommended charger supplied by Toshiba.
- Stop using the battery if you detect any abnormalities, such as odour, discolouration or heat during use, charging or storage.
- Do not use your Toshiba phone with a damaged battery.
- Do not short-circuit the battery. Accidental short-circuiting can occur when a metallic object causes a direct connection between the + and - terminals of the battery.
- Do not touch the battery terminals.
- Do not leave the battery in areas of extreme cold or heat.
- Never soak the battery in water or any other liquid.
- Never attempt to open the battery. The battery contains substances that may be harmful if swallowed or allowed to come into contact with unprotected skin.
- In the unlikely event of a battery leak, take care to keep the battery discharge away from your eyes and skin. If the leakage does come into contact with eyes or skin, flush thoroughly with clean water and consult a doctor.
- Do not dispose of the battery in a fire.
- Do not dispose of the battery in a regular waste container. The battery contains toxic chemicals and must be disposed of appropriately. Contact your local authorities for more information.

Health and safety

AC charger safety

- Do not use a damaged or worn AC charger. The use of a damaged or worn AC charger could result in electric shock, burns or fire. Contact an authorised Toshiba service provider immediately to obtain a suitable replacement.
- Do not bend or twist the cable of the AC charger.
- Do not pull on the cable of the AC charger in order to remove the plug from a socket. Grasp the plug directly when unplugging the AC charger to avoid causing any damage to the cable.
- Do not touch the pins of the plug when connecting or disconnecting it from a power source.
- Do not place heavy objects on the AC charger.
- When the AC charger is not in use, disconnect it from the power source.

Emergency calls

When making emergency calls from your Toshiba phone, ensure that the phone is switched on and in service.

Calls cannot be made to emergency services while data communication is being performed within a GSM area. Also, calls may not be able to be made to emergency services depending on the network services of some service providers.



IMPORTANT: You can make calls to emergency services when the SIM card is not inserted (if supported by the network), the SIM card is locked, the phone is locked, **Call Barring** is set, or **Fixed Dialing** is set.

There is no guarantee that a connection can be established in all countries and areas because operation of your phone differs depending on the wireless network, wireless signal and your setting status. Do not rely solely on your mobile phone when you need to make emergency calls.

Health and safety

FCC notice

This device complies with Part 15 of the FCC rules. Operation is subject to the following two conditions: (1) This device may not cause harmful interference, and (2) This device must accept any interference received, including interference that may cause undesired operation.

Changes or modifications not expressly approved by the party responsible for compliance could void the user's authority to operate the equipment.

Information to user

This equipment has been tested and found to comply with the limits of a Class B digital device, pursuant to Part 15 of the FCC Rules. These limits are designed to provide reasonable protection against harmful interference in a residential installation. This equipment generates, uses and can radiate radio frequency energy and, if not installed and used in accordance with the instructions, may cause harmful interference to radio communications. However, there is no guarantee that interference will not occur in a particular installation; if this equipment does cause harmful interference to radio or television reception, which can be determined by turning the equipment off and on, the user is encouraged to try to correct the interference by one or more of the following measures:

1. Reorient/relocate the receiving aerial.
2. Increase the separation between the equipment and receiver.

Health and safety

3. Connect the equipment into an outlet on a circuit different from the outlet the receiver is currently connected.
4. Consult the dealer or an experienced radio/TV technician for help.



WARNING: Changes or modifications not expressly approved by the manufacturer responsible for compliance could void the user's authority to operate the equipment.

FCC RF exposure information

Your Toshiba phone is a radio transmitter and receiver. It is designed and manufactured not to exceed the emission limits for exposure to radio frequency (RF) energy set by the Federal Communications Commission of the U.S. Government.

The guidelines are based on standards that were developed by independent scientific organisations through periodic and thorough evaluation of scientific studies. The standards include a substantial safety margin designed to assure the safety of all persons, regardless of age and health.

The exposure standard for wireless handsets employs a unit of measurement known as the Specific Absorption Rate, or SAR. The SAR limit set by the FCC is 1.6 W/kg. The tests are performed in positions and locations (e.g., at the ear and worn on the body) as required by the FCC for each model. The SAR value for this model handset when tested for use at the ear is

Health and safety

0.590 W/kg and when worn on the body, as described in this user guide, is 0.885 W/kg.

Body-worn operation

This phone was tested for typical body-worn operations with the back of the phone kept at a distance of 1.5 cm from the body. To maintain compliance with FCC RF exposure requirements, use accessories that maintain a 1.5cm separation distance between your body and the back of the phone. The use of belt clips, holsters and similar accessories should not contain metallic components. The use of accessories that do not satisfy these requirements may not comply with FCC RF exposure requirements, and should be avoided.

The FCC has granted an Equipment Authorization for this model handset with all reported SAR levels evaluated as in compliance with the FCC RF emission guidelines. SAR information on this model handset is on file with the FCC and can be found under the Display Grant section of <https://fjallfoss.fcc.gov/oetcf/eas/reports/GenericSearch.cfm> after searching

on FCC ID SP2-TM5-E01.

Additional information on Specific Absorption Rates (SAR) can be found on the Cellular Telecommunications & Internet Association (CTIA) website at <http://www.phonefacts.net>.

Health and safety

European RF Exposure Information

Your Toshiba phone is a radio transmitter and receiver. It is designed not to exceed the limits for exposure to radio waves recommended by international guidelines. These guidelines were developed by the independent scientific organisation ICNIRP and include safety margins designed to assure the protection of all persons, regardless of age and health.

The guidelines use a unit of measurement known as the Specific Absorption Rate, or SAR. The SAR limit for mobile devices is 2 W/kg and the SAR value for this device when tested at the ear was 0.491 W/kg*. As mobile devices offer a range of functions, they can be used in other positions, such as on the body as described in this user guide**. In this case, the tested SAR value is 0.372 W/kg.

As SAR is measured utilising the device's highest transmitting power, the actual SAR of this device while operating is typically below that indicated above. This is due to automatic

changes to the power level of the device to ensure it only uses the minimum level required to reach the network.

The World Health Organization has stated that present scientific information does not indicate the need for any special precautions for the use of mobile devices. They state that if you want to reduce your exposure then you can do so by limiting the length of calls or using a 'hands-free' device to keep the mobile phone away from the head and body. Additional Information can be found on the website of the World Health Organization (<http://www.who.int/emf>).

* The tests are carried out in accordance with international guidelines for testing.

** Please see **FCC RF exposure information** for further information about body worn operations.

Health and safety

Disposal

The following information is only valid for EU-member states.

Disposal of products



The crossed out wheeled dust bin symbol indicates that products must be collected and disposed of separately from household waste. Integrated batteries and accumulators can be disposed of with the product. They will be separated at the recycling centres.

The black bar indicates that the product was placed on the market after August 13, 2005. By participating in separate collection of

products and batteries, you will help to assure the proper disposal of products and thus help to prevent potential negative consequences for the environment and human health.

For more detailed information about the collection and recycling programmes available in your country, please contact your local city office or the shop where you purchased the product.

Disposal of batteries and/or accumulators



Pb, Hg, Cd

The crossed out wheeled dust bin symbol indicates that batteries and/or accumulators must be collected and disposed of separately from household waste.

Health and safety

If the battery or accumulator contains more than the specified values of lead (Pb), mercury (Hg), and/or cadmium (Cd) defined in the Battery Directive (2006/66/EC), then the chemical symbols for lead (Pb), mercury (Hg) and/or cadmium (Cd) will appear below the crossed out wheeled dust bin symbol.

By participating in separate collection of batteries, you will help to assure the proper disposal of products and batteries and thus help to prevent potential negative consequences for the environment and human health.

For more detailed information about the collection and recycling programmes available in your country, please contact your local city office or the shop where you purchased the product.

Care and maintenance

General

You can greatly enhance the lifespan of your Toshiba phone, and the parts and accessories, by following the suggestions below.



TIP: Maintaining your Toshiba phone, and the parts and accessories, in a good condition will help you fulfil the warranty obligations.

- Always use your Toshiba phone in the intended manner. Incorrect usage may affect performance.
- To avoid permanent damage to your Toshiba phone, use only Toshiba approved batteries and accessories.
- The bundled battery and AC charger are only for use with your Toshiba phone. Do not use this battery or AC charger with any other device. This could cause permanent damage to the device, battery or charger.
- Use of third party equipment (including batteries, cables and accessories) not manufactured or authorised by Toshiba may invalidate the warranty of your phone and adversely affect the operation of the phone.
- Before connecting your Toshiba phone to another device, read the supporting documentation to confirm that the other device is compatible.
- Keep your Toshiba phone, and all parts and accessories, out of the reach of small children and pets.
- Do not allow your Toshiba phone, battery or accessories to come into contact with liquids or moisture. Moisture of any kind can corrode the electronic circuits. The manufacturer's warranty may become invalid if the phone or battery get wet due to misuse.
- Do not use or store your Toshiba phone in dusty or dirty locations.
- Do not use or store your Toshiba phone in hot areas. High temperatures will shorten the lifespan of the phone, damage the battery, and warp/melt internal circuits.

Care and maintenance

- Do not store your Toshiba phone in, or near, direct heat sources such as radiators. This could cause the battery to overheat and explode.
- Do not store your Toshiba phone in cold areas. A big difference between room temperature and the temperature in the phone can cause condensation to form inside the phone, damaging the electronic circuits.
- Do not place your Toshiba phone alongside computer disks, credit cards, travel cards and other magnetic media. Information contained on disks or cards may be affected by the phone.
- Do not expose your Toshiba phone to strong magnetic fields. This may cause temporary malfunction.
- Do not open your Toshiba phone unless absolutely necessary.
- Do not mishandle or abuse your Toshiba phone. Dropping the phone, or knocking or shaking it, can damage the internal circuits.
- Do not apply paint or other such substances to your Toshiba phone.
- Interference may affect the performance of your Toshiba phone. This is normal and the phone should operate as normal once you move away from the source of the interference.
- If your Toshiba phone, or any of the accessories, are not working as they should, please consult your dealer. They can provide you with the expert assistance you require.
- Do not attempt to disassemble your Toshiba phone. Only Toshiba authorised personnel should service the phone.
- When your Toshiba phone is set to vibrate, the vibration may cause the phone to move. Take care not to place the phone near a heat source or the edge of a high surface.
- Only use a soft, clean cloth to clean your Toshiba phone. Do not use chemicals, detergents, abrasive substances, or any liquids. Use a cotton swab to clean the camera lens.

Care and maintenance

- Do not use water to clean the touch screen.
- Keep the touch screen and tip of the stylus clean to avoid permanent damage.
- Keep sharp objects away from the touch screen to avoid it being scratched and damaged.
- For touch screen input, use only the included stylus or your finger. Use of other objects can damage the input panel and will void the warranty.
- If the tip of the stylus is damaged, do not use it. If you operate the touch screen with a damaged stylus, the touch screen may be damaged. When the stylus is damaged, please purchase a new one.
- Do not tap hard on the touch screen, as this may cause permanent damage to the screen.
- To avoid scratches on the touch screen, avoid placing your Toshiba phone with the touch screen facing downwards.
- It is recommended that you use the bundled stylus when pressing the **Reset button**.

Battery care and maintenance

Your Toshiba phone is powered by a rechargeable Lithium ion (Li-ion) battery. The full performance of a new battery is achieved only after two or three complete charge and discharge cycles.

The battery can be charged and discharged hundreds of times, but it will eventually wear out. When the talk and standby times are noticeably shorter than normal, it is recommended that you buy a new battery.

- A new battery, or one that has not been used for a long time, could have reduced capacity during initial use.
- Do not leave the battery connected to the charger and power source for longer than necessary. This will result in repeated short charging, which will reduce battery performance and lifespan. Please disconnect the AC charger when the battery is full.

Care and maintenance

- Do not leave the battery in areas of extreme cold or heat. This could affect the performance of the battery.
- The battery has optimum performance in an ambient temperature of between +5 °C (+41 °F) and +35 °C (+95 °F).
- Only remove the battery with the phone switched off.
- Do not leave the battery empty or disconnected for a long time, as this may cause data to be reset.
- If you are not going to use your phone for a long time, fully charge the battery, then switch off the phone. The phone should be stored in a dry place away from direct sunlight. Recharge the phone approximately every six months.
- Avoid repeated short charging. It is preferable to let the battery go flat and then recharge it completely.

Restarting your Toshiba phone

If you have any problems, such as the phone freezing, restart the phone.

To restart your Toshiba phone:

1. Press and hold the **Power key**.
2. Tap **Power Off** to confirm powering off the phone.
3. Wait a few seconds, then press and hold the **Power key** for approximately two seconds to switch the phone on.



IMPORTANT: If you restart your Toshiba phone, data that you have not saved will be lost.

Care and maintenance

Resetting your Toshiba phone

If you still have problems after restarting your phone, you can reset the phone.

Resetting your Toshiba phone causes it to restart and adjusts memory allocation. Your phone will return to the same status as the last time you used it, though unsaved data may be lost.

To reset your Toshiba phone:

Using the stylus, press and hold the **Reset button**. The phone will switch on after resetting.

 **IMPORTANT:** If you reset your Toshiba phone, data that you have not saved may be lost.

 **TIP:** You can also reset your Toshiba phone by pressing the **Power key** for approximately 15 seconds.

If, after you have reset your Toshiba phone, there is still a problem:

1. Remove the battery (see **Getting started** for instructions).

2. Re-insert the battery, then switch on the phone (see **Getting started** for instructions).

Reinitialising your Toshiba phone

For details of reinitialising your Toshiba phone, see **Master Clear** in **Settings**.

We recommend that you back up all of your data before reinitialising your Toshiba phone.



IMPORTANT: It is recommended that you frequently back up the data on your Toshiba phone.

Getting started

Unpacking

Please ensure that the contents of your sales pack include:

- Your Toshiba phone and stylus
- Battery
- AC charger
- USB cable
- Headset and headset adapter
- Orange Booklet
- Quick Start Guide
- Legal and Safety Information leaflet
- CD (User Guide)



NOTE: If any of the items listed are missing, contact the retailer where you purchased your Toshiba phone.

Getting started

Phone layout and functions

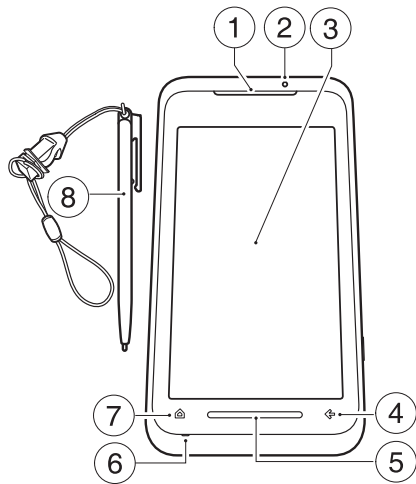

1. **Earpiece**
2. **LED indicator** - indicates various states of the phone.
Red - phone is charging.
Blue - a call, message or notification has been received.
Green - phone is in sleep mode.
3. **Touch screen**
4. **X/OK key** - equivalent to the **X** or **OK** button displayed at the top right corner of the screen.
5. **Touch Sensor (TS) key** - enables you to quickly and easily carry out a number of actions, including zooming in/out when using some applications and opening the **Toshiba Free Pad**.
6. **Microphone**
7. **Home key** - tap to access the **Home Screen**.
8. **Stylus**

Getting started

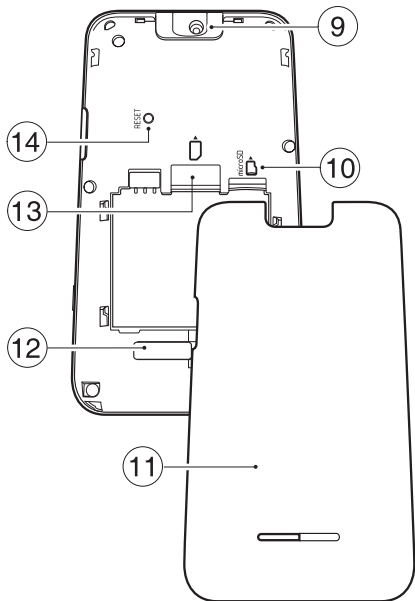

- 9. **Camera lens**
- 10. **microSD card slot**
- 11. **Battery cover**
- 12. **Speaker**
- 13. **SIM card slot**
- 14. **Reset button** - press using the stylus to reset the phone.

Getting started

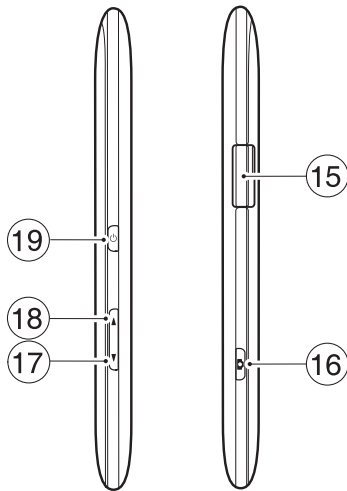

15. **Cable, phone charging and headset connector** (Micro-USB)
16. **Camera key** - long press to launch the **Camera** application.
If **Camera** application is already running, press to capture a photo or begin/stop recording a video clip.
17. **Volume Down key** - short press to decrease the volume.
18. **Volume Up key** - short press to increase the volume; long press to switch between portrait and landscape modes when the **Auto screen orientation change** checkbox is unticked (see **Motion Sensor Settings** in **Settings** for details).
19. **Power key** - short press to enter/leave sleep mode; long press to switch phone on/off; press for approximately 15 seconds to reset phone.

Getting started

Installing the SIM card, microSD card and battery

- i IMPORTANT:** The SIM card is easily damaged by scratching and bending, so take care when handling it.
- i IMPORTANT:** Keep SIM card away from static, dust and water.
- i IMPORTANT:** Power off the phone and disconnect the charger before inserting or removing the SIM card.

To install the SIM card, microSD card and battery:

1. Move the cover of the cable, phone charging and headset connector away from the side of the phone.
2. With the back of the phone facing up, press down on the battery cover. Slide the cover towards the bottom of the phone, then lift it upwards and remove it from the phone.
3. If the battery is already installed, lift the tab at its base, then remove the battery.

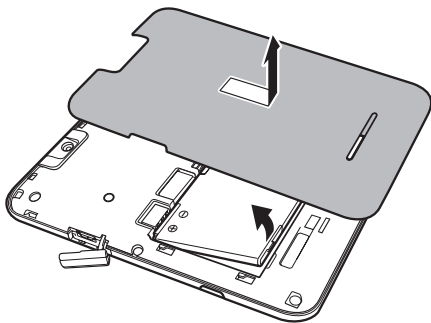

Getting started

4. With the gold connectors facing downwards, align the SIM card the correct way, as shown in the diagram below. Push down lightly while sliding the SIM card into place.

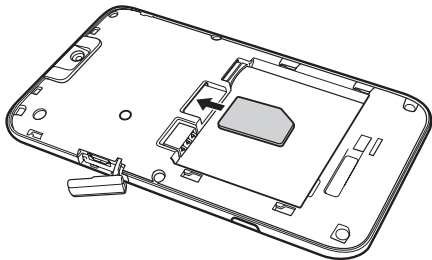

5. With the gold connectors facing downwards, align the microSD card the correct way, as shown in the diagram below. Gently slide the microSD card into the slot until it clicks into place.

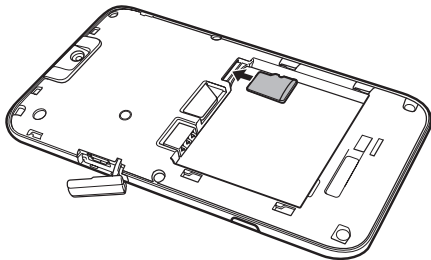

Getting started

To remove the microSD card, gently press it inwards. It will automatically eject.

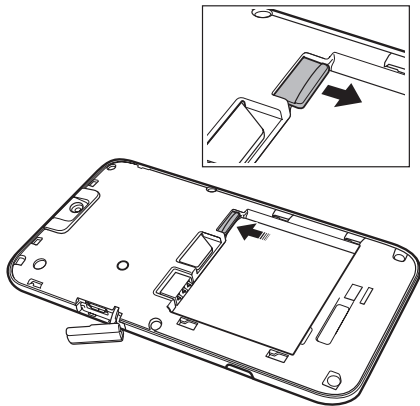

i **IMPORTANT:** Do not remove the microSD card while the phone is reading data from, or writing data to, the card.

💡 **TIP:** Your Toshiba TG01 supports microSDHC™ memory cards. When transferring a memory card from your Toshiba phone to another device, please check with the device manufacturer that SDHC cards are fully supported.

Getting started

6. Insert the battery into the battery compartment with the gold connectors facing towards the top of the phone. The battery is shaped so that it can only be inserted this way. Gently push on the bottom of the battery (non-connector end) to insert it completely.
7. Gently slide the battery cover upward into place.

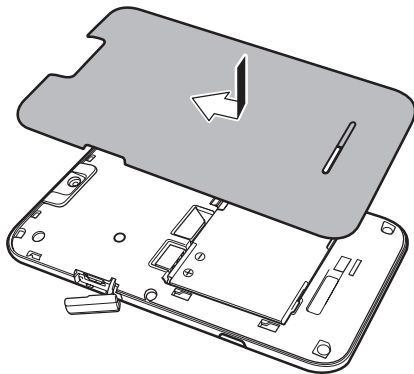
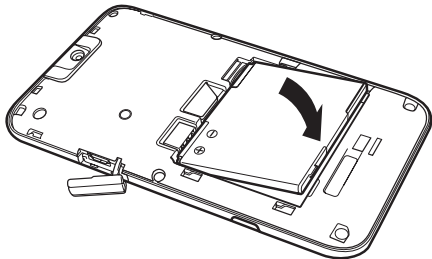

⚠ WARNING: There is a danger of explosion if the battery is incorrectly replaced.

Getting started

Using the stylus

The stylus is used for menu selection and data input on the touch screen of your Toshiba phone.

- Tap: Touch the screen once with the stylus to open items and select options.
- Drag: Hold the stylus on the screen and drag it to select text and images. Drag in a list to select multiple items.
- Tap and hold: Tap and hold the stylus on an item to see a list of actions available for that item. On the pop-up menu that is displayed, tap the required action.

 **IMPORTANT:** For touch screen input, use only the included stylus or your finger. Use of other objects can damage the touch screen and will void the warranty.

 **IMPORTANT:** Do not tap hard on the touch screen, as this may cause permanent damage to the screen.

 **IMPORTANT:** If the tip of the stylus is damaged, do not use it. If you use the touch screen with a damaged stylus, the touch screen may be damaged. When the stylus is damaged, please purchase a new one.

 **NOTE:** Take care not to lose the stylus. It cannot be stored in the phone.

Getting started

Charging the battery

You will need to fully charge the battery before you can switch your Toshiba phone on for the first time. You can charge your battery in the following two ways:

- Either plug the AC charger into an AC outlet and connect it to the charger connector on your Toshiba phone. When the battery is fully charged, unplug the AC charger from the AC outlet and disconnect it from the phone charger connector by gripping it tightly and pulling gently, or
- connect your Toshiba phone to a PC with the USB cable.

 **IMPORTANT:** Do not remove the battery while it is charging.

The battery will only achieve optimum performance after two or three complete charges.

When charging is complete, disconnect the AC charger from the power source, or the USB

cable from the PC, then disconnect your Toshiba phone.

Battery information

Battery performance depends on many factors, such as your service provider's network configuration, signal strength, the temperature of the environment in which you operate your Toshiba phone, the features and/or settings you select and use, items attached to your phone's connecting ports, and your voice, data, and other program usage patterns.

 **NOTE:** It is recommended that you save the data in your phone memory to a PC or storage card. The manufacturer is not responsible for data lost or altered due to battery discharge.

 **TIP:** For information on optimising the power performance of your Toshiba phone, see **Backlight settings**, **Power settings** and **Power Saving Settings** in **Settings**.

Getting started

Low battery

When the battery charge level drops to 10% of its total capacity, an alert message and the low battery icon are displayed.

If the battery charge level runs too low for normal operation, your Toshiba phone will automatically switch off.

Managing a low battery

When the low battery alert is displayed, you should do the following:

1. Save your current data.
2. Charge the battery as soon as possible.
3. If you are unable to charge the battery immediately, we recommend that you switch off your phone.

Switching the power on and off

To switch your Toshiba phone on:

1. Press and hold the **Power key** for approximately two seconds.
2. If a PIN or security code is requested, enter the code.



WARNING: The PIN code activates the services in your Toshiba phone and should be provided in the documentation supplied by your service provider.

If you enter the incorrect PIN for your SIM card three consecutive times, you will need to contact your service provider to obtain the Personal Unblocking Key (PUK). Do not try to guess the PUK as your SIM card will be rendered permanently inoperative following ten consecutive unsuccessful attempts.

Getting started

To switch your Toshiba phone off:

1. Press and hold the **Power key**.
2. Tap **Power Off** to confirm powering off the phone.

Selecting the Home Screen

To change the **Home Screen** after the initial setup:

From the **Home Screen**, tap **Start > Homescreen Selector**.

Toshiba Touch user interface

Overview

The **Toshiba Touch** user interface is a customisable user interface that enables you to access information, run applications, make calls and navigate your Toshiba phone in a simple and quick way, using only one hand.

Toshiba Home Screen

The **Toshiba Home Screen** adds a fast and convenient way to navigate through your Toshiba phone.



Important information such as date, time, status indicators and appointments is displayed on the **Toshiba Home Screen**.

The **Toshiba Home Screen** also includes a menu system of eight stripes of thumbnail icons.

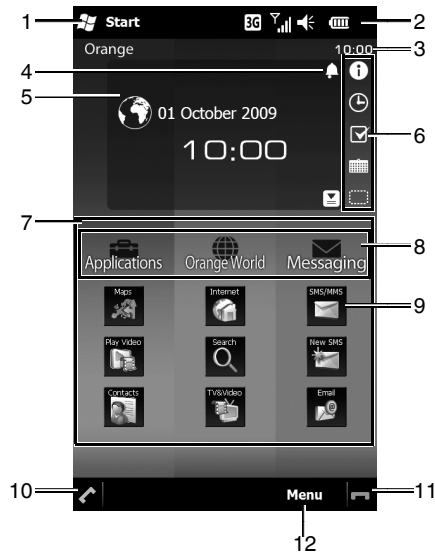
Getting started



1. **Start icon** - tap to access the Windows Mobile **Start Screen**.

2. Status indicators. See **Annex 3 - Common status icons** for further information.
3. Clock - displays the current time. Set to Hide or Show on the **Clock Display Setting** screen.
4. Alarm icon - displays the alarm icon when an alarm has been set.
5. Gadget zone - displays information according to the currently selected gadget item (Information prompt, Clock, ToDo List/ Tasks or Calendar). Tap Clock or Calendar to make changes.
6. Tap an icon to change the item displayed in the gadget zone. To turn off the gadget zone, tap the  icon.
7. **Toshiba Menu**. For details, see **Toshiba Menu**.
8. **Toshiba Menu** headings. For details, see **Toshiba Menu**.
9. **Toshiba Menu** thumbnails. For details, see **Toshiba Menu**.
10.  - used to make, answer and hold calls. Tap to access the **Phone** screen.

Getting started

11.  - ends calls/operations and returns to **Toshiba Home Screen**.
12. **Right softkey** - enables you to change the order and colours of the **Toshiba Menu** stripes, and select the thumbnails.

To access the **Home Screen** at any time, tap the **Home key** or tap .

Toshiba Menu

The **Toshiba Menu** makes it easy to access various applications with your fingertip.

Each stripe consists of a heading and up to three visible thumbnails.

Headings can be specific applications or more general application launchers. Tap a heading to access the application or launcher directly.

Thumbnails can represent specific applications (e.g. **Calendar**), functions of applications (e.g. incoming call history), or specific items (e.g. a picture). Tap a thumbnail to access the required application, function or item.

To view all of the thumbnails in a stripe, slide your finger upwards along the stripe as shown in the diagram below.

Getting started

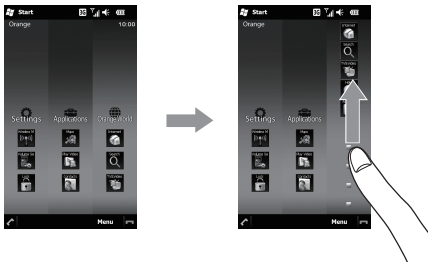

Slide your finger down the stripe to minimise the list of thumbnails.

To view the other stripes, slide your finger left or right as shown in the diagram below.



For information on customising the **Toshiba Menu**, see **Customising the Toshiba Menu** in **Settings**.

Getting started

Motion Sensor

The **Motion Sensor** in your Toshiba phone enables you to quickly and easily carry out a variety of operations.

You can set up your phone to carry out specific operations when you move the phone in a particular way. Examples of the motions and corresponding operations are as follows:

- Change the screen orientation by turning the phone sideways.
- Answer a call by lightly shaking the phone.
- Start **Task Manager** by tapping the back of the phone twice.

For information on setting up the **Motion Sensor**, see **Motion Sensor Settings** in **Settings**.

Toshiba Free Pad

The **Toshiba Free Pad** consists of two items - the **Multi Function Pad** and the **Free Cursor Pad**.

The **Multi Function Pad** operates as cursor (up, down, left, right) and Enter keys. It also enables you to access the **Start Screen**.

The **Free Cursor Pad** displays a mouse pointer on the screen so that you can operate the phone in the same way as using a mouse with a PC.

To open the **Toshiba Free Pad**, slide your finger upwards on the centre of the **TS key**.



To close the **Toshiba Free Pad**, drag it out of the touch screen or tap **X**.

Getting started

Multi Function Pad



1. Moving the **Multi Function Pad**
To display the pad area, tap and hold the upper part of the pad. To move or hide the pad, keep holding this area and move the pad.
2. Up, Down, Left and Right buttons
3. Enter button
Operates as the Enter key for selected items.
4. **Start Screen** button
5. OK/Close buttons
6. Switching pad button
Tap and hold this button to switch to the **Free Cursor Pad**.
7. Close button

Free Cursor Pad



1. Moving the **Free Cursor Pad**
2. Free cursor area
Move the pointer by moving your finger on the pad.
3. Tap area
Tapping this area operates in the same way as clicking the mouse button on an item.
4. Switching pad button
Tap and hold this button to switch to the **Multi Function Pad**.
5. Close button

Getting started

Operator Settings

Using **Operator Settings**, you can quickly and easily configure mobile service provider settings, including GPRS, WAP, and MMS.

To use **Operator Settings**:

1. Access **Easy Connection**.
2. Tap **Operator Settings**.
3. If the required settings are available from the U/SIM, tap the button showing your mobile service provider name.
4. If the settings are not available from the U/SIM, tap **Select Operator**.
5. Tap your country in the list, then tap **Next**.
6. Tap your mobile service provider in the list, then tap **OK**.

Synchronising your Toshiba phone with a PC

ActiveSync (for PCs running Windows XP or earlier)

ActiveSync acts as the gateway between your Microsoft Windows-powered PC and your Toshiba phone. It allows you to synchronise Microsoft Outlook information, Microsoft Office documents, pictures, music, videos and applications to and from your device.

In addition to synchronising with a PC, **ActiveSync** allows you to synchronise Microsoft Outlook information directly with Microsoft Exchange Server 2003 and Microsoft Exchange Server 2007, so that you can keep your e-mail, calendar data, tasks and contact information updated wirelessly when you're away from your PC.

You can install **ActiveSync** by downloading it from the Microsoft website.

Getting started

Once the software has been installed and your Toshiba phone is connected to your PC, the ActiveSync Setup Wizard is started. Simply follow the on-screen instructions.

If you are not synchronising directly with a Microsoft Exchange server, do not select the option to synchronise directly with a server. The alternative is to synchronise your Toshiba phone with your PC. You cannot do both at the same time.

Starting and stopping ActiveSync synchronisation

To start and stop synchronisation:

1. Access **ActiveSync**. For details, see **Accessing applications and settings in Annex 2 - Navigating your Toshiba phone**.
2. To start synchronisation, tap **Sync**.
3. To stop synchronisation, tap **Stop**.

Changing ActiveSync settings

Once you have set up synchronisation using the ActiveSync Setup Wizard on the PC, you can change your synchronization settings at a later stage:

- If you want to change **ActiveSync** settings for synchronising with a PC, use **ActiveSync** on the PC. For more information, see ActiveSync Help on the PC.
- If you want to change **ActiveSync** settings for synchronising with an Exchange server, use **ActiveSync** on your Toshiba phone.



NOTE: Disconnect your Toshiba phone from your PC before changing the synchronisation settings.

Getting started

Windows Mobile Device Center (for PCs running Windows Vista)

The Windows Mobile Device Center:

- Combines an efficient synchronisation platform with a compelling user experience.
- Enables you to set up new partnerships, synchronise content and manage music, pictures and video with Windows Mobile powered devices (Windows Mobile 2003 or later).
- Helps you to synchronise information such as e-mail, contacts and calendar appointments, easily manage your synchronisation settings, and transfer documents between your device and PC.



You can install Windows Mobile Device Center (WMDC) by downloading it from the Microsoft website.

For further information on **ActiveSync** and WMDC, refer to the Help on your PC.

Call functions

Receiving a call

Answering or ignoring a call



- To answer an incoming call, tap  or **Answer**.
- To ignore an incoming call, tap  or **Ignore**.



NOTE: If you choose to ignore a call, the caller will be connected to your voice mail, provided you are subscribed to this service.



TIP: When you have an incoming call while the screen lock is activated, you can do the following:

- Answer the incoming call by sliding the  to the right.
- Ignore the incoming call by sliding the  to the right.



TIP: When you have the headset connected to your Toshiba phone, you can do the following:

- Answer an incoming call by pressing the headset button.
- Ignore an incoming call by pressing and holding the headset button.

Ending a call

To end a call, tap  or **End**.



TIP: When you have the headset connected to your Toshiba phone, you can end a call by pressing and holding the headset button.

Call functions

Making a call

Before making a call, ensure that your Toshiba phone is switched on, that there is a valid SIM card installed, and that the signal is sufficiently strong.

Making a call from the Phone screen

To make a call from the **Phone** screen:

1. Access the **Phone** screen.
2. Enter a phone number using the numeric keypad.
3. Tap  or **Talk**.

Dialling the last number called

To dial the last number called:

From the **Toshiba Home Screen**, tap  twice.

Making a call from Contacts

To make a call from **Contacts**:

1. Access **Contacts**.
2. Scroll to the required contact, then tap .



TIP: If you have a long list of contacts, enter the first few letters of the contact's name. The phone will display only the matching contact. To call the contact, tap



TIP: A work phone number (**w**), mobile phone number (**m**) and home phone number (**h**) can be assigned to a contact that is saved to the phone.

The mobile phone number is dialled by default.

To call a non-default number:

1. Tap the required contact.
2. Scroll to the required phone number, then tap  or **Call**.

Call functions

Making an international call

To make an international call:

1. Access the **Phone** screen.
2. Tap and hold **0** on the keypad until the + sign is displayed.
3. Enter the full phone number, including the country code, area code (without the first **0**) and phone number.
4. Tap  or **Talk**.

Speed Dial

Creating a speed dial

To create a speed dial:

1. Access the **Phone** screen.
2. Tap **Speed Dial**.
3. Tap **Menu > New**.
4. Tap the required contact.
5. In the **Location:** field, select the speed dial number.
6. Tap the **X/OK key** or **OK** twice.



NOTE: The digit **0** is reserved for inserting the + character when dialling an international phone number. The digit **1** is reserved for calling your voice mail mailbox as a speed dial.

Call functions



TIP: To create a speed dial from

Contacts:

1. Tap the required contact.
2. Scroll to the required phone number, then tap **Menu > Add to Speed Dial....**
3. In the **Location:** field, select the speed dial number.
4. Tap the **X/OK key** or **OK** twice.

Making a call using speed dial

To make a call using speed dial:

1. Access the **Phone** screen.
2. Tap **Speed Dial**.
3. Scroll to the required speed dial, then tap  or **Call**.



TIP: To make a call using speed dial from the **Phone** screen:

From the **Phone** screen, tap and hold the required speed dial number on the keypad. If the speed dial number has two digits, tap the first digit, then tap and hold the second digit.

In-call options

Adjusting the volume

To adjust the volume while in a call:

Press the **Volume Up key** to increase the volume, and the **Volume Down key** to decrease the volume.

Putting a call on speakerphone

To put a call on speakerphone, tap **Speaker On** or **Menu > Turn Speakerphone On**.

To switch the speakerphone off, tap **Speaker Off** or **Menu > Turn Speakerphone Off**.



NOTE: The speakerphone is automatically switched off at the end of a call.

Muting a call

To mute a call, tap **Mute** or **Menu > Mute**.

To unmute the call, tap **Unmute** or **Menu > Unmute**.

Call functions

Putting a call on hold

To put a call on hold, tap , **Hold** or **Menu > Hold**.

To unhold the call, tap , **Unhold** or **Menu > Unhold**.



TIP: When you have the headset connected to your Toshiba phone, you can place a call on hold by pressing the headset button.

To unhold the call, press the button again.

Putting a call on hands-free

To put a call on hands-free:

When hands-free equipment is attached to your Toshiba phone, the item **Menu > Turn Hands-free On** will be enabled.

Multiple and multiparty calls

Answering or ignoring a second call

- To answer a second call, tap  or **Answer**. The original call will be put on hold.
- To ignore a second call, tap **Ignore**.



NOTE: To interact with a second call, you need to have **Call Waiting** enabled. For information on enabling **Call Waiting**, see **Call Waiting** in **Settings**.

Making a second call

To make a second call while already in a call:

1. Tap **Hold** or **Menu > Hold** to put the first call on hold.
2. Tap **Keypad** to display the numeric keypad.
3. Dial the second number, then tap  or **Talk**. The first call will remain on hold.

Swapping between calls

To swap between calls, tap , **Swap** or **Menu > Swap**.

Call functions

Creating a conference call

To create a conference call:

With two calls active on your Toshiba phone, one active and the other on hold, tap **Menu > Conference**. The calls will be joined together, and each party will be able to hear the other.



NOTE: The conference call feature is dependent on your service provider supporting it.



TIP: To add another party to the conference call:

1. Tap **Hold** or **Menu > Hold** to put the conference call on hold.
2. Dial the number for the new party, then tap  or **Talk**.
3. When the new party has answered, tap **Menu > Conference**.

Having a private conversation with a conference call party

To have a private conversation with a conference call party, you need to split the conference call.

To have a private conversation from a conference call:

1. Tap **Menu > Private**.
2. Scroll to the party with whom you wish to have the private conversation, then tap **Private**.

Call functions

Call History

Call History displays a list of calls that you have missed, received and dialled recently.

Viewing Call History

To view **Call History**:

1. Access **Call History**.
2. If required, you can filter the list by tapping **Menu > Filter > Missed/Outgoing/Incoming**.
3. To view the details of a call, tap the required call.

Deleting Call History records

To delete a call from **Call History**:

1. Access **Call History**.
2. Scroll to the required entry in the list, then tap **Menu > Delete**.
3. Tap **Yes** to confirm the deletion.

To delete all calls from **Call History**:

1. Access **Call History**.
2. Tap **Menu > Delete All Calls**.

3. Tap **Yes** to confirm the deletion.

 **NOTE:** Deleting all calls from the **Call History** does not reset the **Call Timers**. These need to be reset separately (see **Resetting Call Timers**).

Viewing Call Timers

To view **Call Timers**:

1. Access **Call History**.
2. Tap **Menu > Call Timers....**

 **NOTE:** The length of waiting calls is not recorded.

Resetting Call Timers

To reset **Call Timers**:

1. Access **Call History**.
2. Tap **Menu > Call Timers....**
3. Tap **Reset**.

Messaging

You can create, send, receive, organise, delete and store the following message types on your Toshiba phone:

- Short Message Service (SMS) messages.
- Multimedia Messaging Service (MMS) messages.
- E-mail.

Text messages

Text messaging, or the Short Message Service (SMS), enables you to exchange text messages with other phones. For details on text messages, contact your service provider.

For information on setting up your text message service centre, see **Setting up text messages service centre** in **Annex 4 - Configuring SMS, MMS and e-mail**.

Your Toshiba phone supports the sending of more than the standard 160-character limit. If you enter more than 160 characters, the message is split into linked text messages. These linked messages will be sent at the same time.

Receiving text messages

Text messages are automatically received when your Toshiba phone is switched on. When your phone is off, messages are held by your service provider until the next time your phone is connected to the network.

Your Toshiba phone will alert you when a new text message arrives.

When you have an ongoing conversation using text messages, the messages are threaded together into a single conversation. This enables you to view the entire conversation as you type.

Replying to a text message

To reply to a text message:

1. Access **SMS/MMS**.
2. From **Inbox**, tap **Reply**. If you are replying to multiple recipients, tap **Menu > Reply/Forward > Reply All**.
3. Enter your message.
4. Tap **Send**.

Messaging

Forwarding a text message

To forward a text message:

1. Access **SMS/MMS**.
2. From **Inbox**, tap **Menu > Reply/Forward > Forward**.
3. Add recipient(s). For details of how to add a recipient, refer to **Creating and sending a text message**.
4. If required, edit the message in the message area.
5. Tap **Send**.

Creating and sending a text message

To create and send a text message:

1. Access **SMS/MMS**.
2. Tap **Menu > New > SMS**.
3. Add recipient(s) using one or more of the following methods:
 - With the cursor in the **To:** field, tap **Menu > Add Recipient...**, then tap a recipient from the list of contacts.
 - With the cursor in the **To:** field, enter the first

few letters of a name stored in **Contacts**, then tap **Menu > Check Names**. If several matches are displayed, select the required one.

- Enter mobile phone number(s) in the **To:** field. Use a semicolon to separate multiple recipients.
 - Tap **To:**, then tap a recipient from the list of contacts.
4. Scroll to the message area and enter your message.
 5. Tap **Send**.

Options available when creating a text message

To convert the message to an MMS message, tap **Menu > Insert**, then tap the type of item that you want to add to the message.

To save time by inserting predefined text, tap **Menu > My Text**, then select the text to insert. You can also edit existing **My Text** items as required.

To save a message as a draft, tap **Menu > Save**

Messaging

to Drafts.

To check spelling before sending the message, tap **Menu > Spell Check**.

To delete the message without sending it, tap **Menu > Cancel Message**.

Requesting delivery notification

To request a delivery notification:

1. Tap **Menu > Message Options....**
2. Tick the **Request message delivery notification** checkbox.
3. Tap the **X/OK key** or **OK**.

MMS messages

The Multimedia Messaging Service (MMS) enables you to exchange multimedia messages containing data such as text, pictures, sounds, animation and video clips. You can send MMS messages to other mobile phones or to e-mail addresses. For details of MMS, and to enable your account for this service, contact your service provider.

For details of configuring MMS settings manually, see **Configuring MMS settings in Annex 4 - Configuring SMS, MMS and e-mail**.

Receiving MMS messages

Your Toshiba phone will alert you when a new MMS message arrives. Depending on your settings, the message contents may download a few moments later.



To view the MMS message, tap the message in the **SMS/MMS Inbox**, then tap .

Messaging

Creating an MMS message

An MMS message can consist of many pages, also known as 'slides'. Each slide can hold an image, a sound and text, but you do not need to set all of these for each message. The maximum amount of content that can be sent in a message is set by your service provider.

To create an MMS message:

1. Access **SMS/MMS**.
2. Tap **Menu > New > MMS**.
3. Add recipient(s) using one or more of the following methods:
 - Tap **Menu > Add Recipient > From Contacts.../From Call History.../From Sent History...**, then tap a recipient.
 - Tap , then tap a recipient from the list of contacts.
 - Tap **Insert contacts here** field, then tap , and tap a recipient from the list of contacts.
, and enter mobile phone number(s) or e-mail address(es). Use a semicolon to separate multiple recipients.



, and tap a recipient from sent history.

, and tap a recipient from call history.

4. Enter a message. (Insert the subject if required.)
5. Tap **Send** when the message is ready.

Options available when creating an MMS message

Changing to carbon copy (Cc) or blind carbon copy (Bcc)

After adding recipient(s) to your message, you can change to carbon copy  or blind carbon copy  by the following steps.

1. Tap the added recipient(s) in **Insert contacts here** field.
2. Select a recipient from the list.
3. Tap **Menu > Change to Cc** or **Change to Bcc**, then tap **Done**.

Inserting a picture or video



To insert a picture or video in the message:

1. Tap  or **Menu > Insert > Picture/Video....** A preview of all pictures and

Messaging

videos in the current folder is displayed.

2. Either select one of the previewed pictures or

launch the **Camera** application and capture a new picture by tapping  or a new video by tapping .

Once you have selected a picture or video, the message creation screen is displayed again.







TIP: You can capture a new picture or video from the message creation screen by tapping **Menu > Capture > Image.../ Video....**

Inserting text

To insert text in the message:



1. Tap notepad or **Menu > Insert > Text....**
2. Enter text. To insert predefined text, tap  or tap **Menu > Insert My Text....**

You can also insert emoticon, favorite, contact, and calendar by tapping , , , and , respectively, or selecting these options from the **Menu** (right softkey).

3. Tap **Done** when you have finished inserting text.





Inserting audio

To insert audio in the message:

1. Tap  or **Menu > Insert > Audio....** A list of all audio files in the current folder is displayed.
2. Either select an audio file, or launch the **Audio Recorder** and capture a new audio by tapping  or tapping **Menu > Capture > Audio....**

Inserting file

To insert file in the message:

1. Tap , or **Menu > Attachment....**
2. Tap , , or  to add vCard, vCalendar, any file, respectively, or select these options from the **Menu** (right softkey).

To use or create a template:

Tap **Menu > Template**. Tap **Select a Template...** to select a template to use for a new MMS message, or **Save as Template** to

Messaging

save the current MMS message as a template for future use.

To preview the message before sending, tap the .

To delete the message without sending it, tap **Menu > Cancel Message**.

To select a background colour for the message, tap **Menu > Options > Background**, then tap the required colour.

You can also set the priority of the message, a delivery time delay for the sending of the message, an expiry time for the message, and request delivery and read reports.

To set these options, tap **Menu > Options > Send Options...**, then set the options as required.

E-mail

Before you can send or receive e-mails, you need to set up an e-mail account. Your Toshiba phone supports the following types of e-mail accounts:

- Internet e-mail (POP3/IMAP).
- Exchange server (Outlook).

For details of setting up e-mail accounts, see **Setting up e-mail accounts in Annex 4 - Configuring SMS, MMS and e-mail**.

Creating an e-mail

To create an e-mail:

1. Tap **Start > E-mail**.
2. Tap the e-mail account to use.
3. Tap **Menu > New**.
4. Add recipient(s) using one or more of the following methods:
 - With the cursor in the **To:** field, tap **Menu > Add Recipient...**, then tap a recipient from the list of contacts.

Messaging

- With the cursor in the **To:** field, enter the first few letters of a name stored in **Contacts**, then tap **Menu > Check Names**. If several matches are displayed, select the required one.
 - Enter e-mail address(es) in the **To:** field. Use a semicolon to separate multiple recipients.
 - Tap **To:**, then tap a recipient from the list of contacts.
5. Scroll to the message area and enter your message.
 6. Tap **Send** when the message is ready. E-mails are stored in your **Outbox** and are sent to recipients the next time you synchronise or connect to your e-mail server.

Options available when creating an e-mail

You can add recipients in the **Cc:** and/or **Bcc:** fields.



TIP: Scroll up to view the **Cc:** and **Bcc:** fields.

You can enter a subject for the e-mail in the **Subject:** field.

To add an attachment, tap **Menu > Insert > Picture/Voice Note/File**, then select the item to add.

To save time by inserting predefined text, tap **Menu > My Text**, then select the text to insert.

To save a message as a draft, tap **Menu > Save to Drafts**.

To check spelling before sending the message, tap **Menu > Spell Check**.

To delete the message without sending it, tap **Menu > Cancel Message**.

To set the priority of the e-mail, tap **Menu > Message Options...**, then select the required option in the **Priority:** field.

Messaging

Sending and receiving e-mail

To send and receive e-mail:

1. Tap **Start > E-mail**.
2. Tap the required e-mail account.
3. Tap **Menu > Send/Receive**. Your Toshiba phone connects to your Internet e-mail server and sends and receives your messages.



TIP: To stop this process, tap **Menu > Stop Send/Receive**.

Downloading a complete e-mail

To download a complete e-mail:

1. Tap **Start > E-mail**.
2. Tap the required e-mail account.
3. Tap the required e-mail, then tap **Menu > Download Message**. The complete message is retrieved the next time you synchronise or connect to your e-mail server to send/receive e-mail.

Downloading and viewing an e-mail attachment

To download and view an e-mail attachment:

From an open message with an attachment, tap the attachment. The attachment is downloaded the next time you synchronise or connect to your e-mail server to send/receive e-mail.

After it has been downloaded, you can tap the attachment to view it.

Applications and multimedia

Office Mobile

Excel Mobile

With **Excel Mobile** you can work on spreadsheets in the same way as on a PC. You can create new spreadsheets and charts, and open and edit workbooks created on a PC.

 **NOTE: Excel Mobile** does not fully support some features. See the Microsoft website for details.

 **NOTE:** Some data and formatting may be lost when you save a workbook created on a PC to your Toshiba phone. See the Microsoft website for details.

OneNote Mobile

With **OneNote Mobile**, you can gather notes and information in one place.

Notes in **OneNote Mobile** can contain text, images and voice recordings. You can also synchronise the notes with **OneNote** on a PC using **ActiveSync**.

PowerPoint Mobile

With **PowerPoint Mobile**, slide show presentations created on your PC can be opened and viewed on your Toshiba phone.

 **NOTE: PowerPoint Mobile** does not fully support some features. See the Microsoft website for details.

Word Mobile

With **Word Mobile** you can work on documents in the same way as on a PC. You can create new documents and templates, and open and edit documents created on a PC.

 **NOTE: Word Mobile** does not fully support some features. See the Microsoft website for details.

 **NOTE:** Some data and formatting may be lost when you save the document on your Toshiba phone. See the Microsoft website for details.

Applications and multimedia

Calendar

The **Calendar** application works like an electronic diary. You can keep track of your appointments, including meetings and other events.

You can display reminders on your Toshiba phone, as well as synchronising your phone with Outlook on your PC.

You can also schedule meetings via e-mail with contacts who use **Microsoft Outlook** or **Outlook Mobile**.

Scheduling an appointment

To schedule a new appointment:

1. Access **Calendar**.
2. Tap **Menu > New Appointment**.
3. Enter details of the appointment, then tap the **X/OK key** or **OK**.



TIP: To send a meeting request:

1. Tap the **Attendees:** field.
2. Tap **Add Required Attendee...** or **Add Optional Attendee...** as required.
3. Tap the contact to invite.
4. Add more contacts if required.
5. Tap the **X/OK key**, **OK** or **Done** when you have finished adding attendees.
6. Tap the **X/OK key** or **OK**.
7. Tap **Yes** to save the change and send the meeting request to the attendees.

The meeting request will be sent to the attendees when you next synchronise your Toshiba phone with your PC.

When attendees accept the meeting request, the meeting is automatically added to their schedules. When their responses are received, your calendar is updated.

Applications and multimedia

Sending an appointment

You can send an appointment within an MMS message.

To send an appointment:

1. Access **Calendar**.
2. Tap the required appointment.
3. Tap **Menu > Send as vCalendar**.
4. Add a recipient to the message, then tap **Send**.

Changing the default reminder time

By default, the reminder time is set to 15 minutes before an appointment.

To change the default reminder time:

1. Access **Calendar**.
2. Tap **Menu > Tools > Options...**
3. Tap the **Appointments** tab.
4. Make sure that the **Set reminders for new items** checkbox is ticked, then change the reminder time.
5. Tap the **X/OK key** or **OK**.

Changing the Calendar view

To change the **Calendar** view:

Tap the **Left softkey** to toggle between **Agenda, Day, Week, Month** and **Year** views.



TIP: You can also change the **Calendar** view by tapping **Menu > View**, then tapping the required view.

Applications and multimedia

Contacts

You can use the **Contacts** feature to store phone numbers, e-mail addresses, home addresses, and other information relating to a contact. You can also add a picture or assign a ring tone to a contact.

If you use **Microsoft Outlook** on a PC, you can synchronise contacts between your Toshiba phone and the PC.

Creating a new contact

To create a new contact:

1. Access **Contacts**.
2. Tap **New**.
3. Tap the contact type to create (**Outlook Contact** or **SIM Contact**). Outlook contacts are stored on your Toshiba phone.

 **NOTE:** SIM contacts (except when using a USIM card) only support a single name and phone number. Contacts stored on a USIM card can include a name, three phone numbers and an e-mail address.



NOTE: If you move the SIM card to another phone, your SIM contacts are moved as well.

4. Enter the details of the new contact.
5. Tap the **X/OK key** or **OK**.



TIP: You can customise Outlook contacts by adding a picture or a ring tone to uniquely identify the person calling you.



TIP: If someone whose phone number is not stored in **Contacts** calls you, you can create a contact for that person. To do this:

1. Access **Call History**.
2. Scroll to the required call, then tap **Menu > Save to Contacts**.
3. Tap **<New Contact>**.
4. Tap the contact type to create.
5. Edit the details of the new contact as required, then tap **Save**.

Applications and multimedia

Finding a contact

To find a contact by name:

1. Access **Contacts**.
2. Tap the **Enter a name...** field.
3. Enter the first letter of the name of the contact to find. Matching contacts will be listed.

Copying contacts

To copy a phone contact to the SIM card:

1. Access **Contacts**.
2. Tap the required contact.
3. Tap **Menu > Save to SIM**.

 **NOTE:** When copying phone contacts to a SIM card, only the supported fields will be copied.

To copy a SIM contact to the phone:

1. Access **Contacts**.
2. Tap the required contact.
3. Tap **Menu > Save to Contacts**.

To copy all phone contacts to the SIM card:

1. Access **SIM Manager**.

2. Tap the picture of the phone.

3. Tap **Menu > Select All**.

4. Tap **Menu > Copy to SIM**.

5. Tap the **X/OK key** or **OK** after the copying has finished.

6. Tap the **X/OK key** or **OK** twice to exit the **SIM Manager** application.

To copy all SIM contacts to the phone:

1. Access **SIM Manager**.

2. Tap the picture of the SIM card.

3. Tap **Menu > Select All**.

4. Tap **Menu > Copy to Phone**.

5. Tap the **X/OK key** or **OK** after the copying has finished.

6. Tap the **X/OK key** or **OK** twice to exit the **SIM Manager** application.

Deleting contacts

To delete a contact:

1. Access **Contacts**.

2. Tap the required contact.

3. Tap **Menu > Delete Contact**.

Applications and multimedia

4. Tap **Yes** to confirm the deletion.

To delete all contacts:

1. Access **Contacts**.
2. Tap **Menu > Select Contacts > All**.
3. Tap **Menu > Delete**.
4. Tap **Yes** to confirm the deletion.

To delete all contacts from the phone:

1. Access **SIM Manager**.
2. Tap the picture of the phone.
3. Tap **Menu > Select All**.
4. Tap **Menu > Delete**.
5. Tap **Yes** to confirm the deletion.
6. Tap the **X/OK key** or **OK** after the deleting.
7. Tap the **X/OK key** or **OK** twice to exit the **SIM Manager** application.

To delete all contacts from the SIM card:

1. Access **SIM Manager**.
2. Tap the picture of the SIM card.
3. Tap **Menu > Select All**.
4. Tap **Menu > Delete**.
5. Tap **Yes** to confirm the deletion.

6. Tap the **X/OK key** or **OK** after the deleting.
7. Tap the **X/OK key** or **OK** twice to exit the **SIM Manager** application.

Sending contact information

You can send contact information in a text message or MMS message, or using Bluetooth.

To send contact information in a text message:

1. Access **Contacts**.
2. Tap the required contact.
3. Tap **Menu > Send Contact > SMS/MMS**.
4. Select the specific information to send, then tap **Done**.
5. Add a recipient to the message, then tap **Send**.

To send contact information in an MMS message:

1. Access **Contacts**.
2. Tap the required contact.
3. Tap **Menu > Send as vCard**.
4. Add a recipient to the message, then tap **Send**.

Applications and multimedia

For details of sending contact information using Bluetooth, see **Beaming an item in Connectivity**.

Internet Explorer



Internet Explorer Mobile gives quick and easy access to searching using **Live Search** and web pages in your **Favorites** and **History**.

You can also type in an address to access other web pages.

Accessing a web page

To access a web page:

1. Access **Internet Explorer**.
2. Tap the address bar.
3. Enter a web page address.
4. Tap the arrow icon to the right of the address bar.

 **TIP:** To return to the home page, tap  > **Home Page**.



Changing the text size of web pages

To change the text size of a web page:

1. From a web page, tap  > **View** > **Text Size**.
2. Tap the required size.

Adding a web page to Favorites

To add a web page to **Favorites**:

1. From a web page, tap  > .
2. Edit the details if required, then tap **Add**.

Zooming in or out on a web page

To zoom in or out on a web page:

1. From a web page, tap .
2. Zoom in or out by using the zoom bar.

Changing the home page

To change the home page:

1. From a web page, tap  > **Tools** > **Options**.
2. Tap **Home Page**.
3. Tap one of the following options:

Applications and multimedia

- **Default Home page** - to use the default home page.
 - **Current page** - to set the current web page as the home page.
 - **Custom page** - to set a new home page. Enter the address of the new home page in the field below.
4. Tap **Done**.

Clearing temporary files, cookies and History

When you use the Internet, your Toshiba phone stores data that uses up some of the storage capacity of the phone. You can delete these files to free up storage.

To clear temporary files, cookies and **History**:

1. Access **Internet Explorer**.
2. Tap  > **Tools** > **Options**.
3. Tap **Browsing History**.
4. Scroll to the item to clear, then tap **Clear**.
5. Tap **Yes** to confirm the deletion.
6. Tap **Done** when you have finished.

Sending a link

To send a link using **Messaging**:

1. From a web page, tap  > **Tools** > **Send Link...**
2. Select the **Messaging** account to use to send the link. A new message is created with the web page address in the body of the message.
3. Add a recipient and edit the message if required.
4. Tap **Send**.

Increasing the speed of your Internet browser

For details of increasing the speed of your Internet browser, see **Browser Settings** in **Settings**.

Games

Your Toshiba phone comes preloaded with the following games:

- **Bubble Breaker**
- **Monopoly World Demo**
- **NFS Undercover Demo**
- **Solitaire**

Applications and multimedia

Camera

Your Toshiba phone is equipped with a digital camera that can be used to capture photographs and video clips.







Starting the Camera

You can launch the **Camera** application using one of the following methods:

- From the **Toshiba Home Screen**, tap **Start > Camera**.
- Press and hold the **Camera key**.

Main Camera screen

The following options are available from the main **Camera** screen:

-  - to access the **Camera** menu items.
-  - to change the screen orientation.
-  - to toggle the capture mode between the following modes:
 -  - default, to capture a single photograph.
 -  - to capture a video.
 -  - to capture a series of 9 photos. This feature is useful for capturing a photograph

of a subject in motion.

 - to capture a photograph after approximately 5, 10 or 15 seconds. This feature is useful for capturing a photograph that you can be in.

-  - to select the required resolution for the photo or video.



 **NOTE:** Images of higher resolution (quality) will use more storage space.

-  - to zoom in and out.

Capturing a photo





To capture a photo:

1. Start the **Camera**.
2. Aim the camera at the subject, then press the **Camera key** or tap . A preview of the photo is displayed.

 **TIP:** To activate the auto-focus feature, tap  before capturing the photo.

3. Select the required action from the following:



Applications and multimedia



- tap  to save the photo.
- tap  > **Send** to send the photo in an MMS message or e-mail.
- tap  or  > **Delete**, then  to delete the photo.

Capturing a video

 **NOTE:** Close all open applications before capturing videos with maximum resolution (640 x 480). This will avoid any deterioration in the video quality.







To capture a video:

1. Start the **Camera**.
2. Tap  or  > **Capture Mode** > **Video**.
3. Aim the camera at the subject, then press the **Camera key** or tap  to start recording.

 **TIP:** To capture the video without sound, tap  before capturing the video. The icon will change to .

4. Press the **Camera key** or tap  to stop recording.

5. Select the required action from the following:

- tap  to save the video.
- tap  > **Play** to play the video.
- tap  > **Send** to send the video in an MMS message or e-mail.
- tap  or  > **Delete**, then  to delete the video.

Changing storage location

By default, all photographs and videos taken with the **Camera** are saved in the **My Pictures** or **My Videos** folder on your Toshiba phone.

To save photographs and videos on a storage card:

1. Ensure that a storage card has been installed (refer to **Installing the SIM card, microSD card and battery in Getting started** for installation instructions).
2. Start the **Camera**.
3. Tap  > **Settings....**
4. Tap the **General** tab.
5. In the **Save to:** field, select **Storage Card**.

Applications and multimedia

6. Tap the **X/OK** key or **OK**.

CorePlayer

With **CorePlayer**, you can take control of your mobile multimedia playback using

CorePlayer's simple yet powerful interface and features. It also comes with built-in YouTube support.

For any further information, visit <http://support.corecodec.com/>.

File Explorer

File Explorer enables you to view and manage files saved in your Toshiba phone, or on a storage card.

Getting Started

Getting Started gives you step-by-step instructions for carrying out common procedures with your Toshiba phone.

Java

Your Toshiba phone supports Java applications (also known as MIDlets) that are written for mobile devices. Java applications include games and utilities.

Your phone supports Java 2 Edition, J2ME.

The **Java** application on your Toshiba phone enables you to download, install and manage Java applications.

Installing a Java application

To install a Java application:

1. Access **Java**.
2. Tap **Menu > Install**.
3. Select where to install the application from:
 - To install from a website, tap **Browser**. This will launch the default browser. Go to the website with the required Java application and download the application. It is then loaded into the **Java** application.
 - To install from a specific URL, tap **URL**. If the URL has already been entered, tap it, then tap **Go**.

Applications and multimedia

If the URL has not been entered, tap **Add**, enter a name for the URL and the web address, then tap **OK**.

- To install an application stored on your Toshiba phone, tap **Local Files**. All uninstalled Java applications stored on the phone and the storage card are displayed. Tap the one to install.
4. The details of the selected application will be displayed and you will be prompted to confirm the installation. Tap **Continue** to install the application.
 5. Select the folder in which to install the application, then tap **OK**.
 6. Wait a few seconds while the application is installed. You can then run the application.

Running a Java application

Once Java applications are successfully installed, they are displayed on the main **Java** screen.

To run a Java application:

1. Access **Java**.

2. Tap the required application.

Marketplace

Marketplace is an integral part of the mobile experience. **Marketplace** allows you to expand your Toshiba phone's capabilities through powerful software.

You can manage your **Marketplace** account and application purchases directly from your Toshiba phone.

Microsoft My Phone

My Phone is a service that allows you to back up your Toshiba phone data to a password-protected server online. My Phone backs up your contacts and appointments through your Web account. My Phone also allows you to share the photos on your Toshiba phone with your family and friends.

Applications and multimedia

Notes

With **Notes**, you can quickly capture ideas, questions, reminders, to-do lists and meeting notes by writing, typing or recording your voice in a note. This is especially useful when you don't have a pen and paper to hand.

For further details of **Notes**, see **Writing and drawing on the screen** in **Annex 1 - Text input**.

Creating a note

To create a note:

1. Access **Notes**.
2. Tap **New**.
3. Change the input method if required. See **Input methods** in **Annex 1 - Text input** for further details.
4. Enter the note using your selected input method.
5. Tap the **X/OK key** or **OK** when you have finished.



NOTE: To record a voice note, use the recording toolbar.

If this bar is not displayed, tap **Menu > View Recording Toolbar**.

Viewing or playing a note

To view or play a note:

1. Access **Notes**.
2. Tap the note to view or play.

PhotoBase

PhotoBase is an image manager that enables you to manage and quickly preview images stored on your Toshiba phone. It also enables you to edit images and display your favourite images on the **Calendar**.

Applications and multimedia

Pictures & Videos

Viewing pictures and videos

You can view pictures and videos stored on your Toshiba phone or storage card using the

Pictures & Videos application.

To view pictures and videos:

1. Access **Pictures & Videos**.
2. Tap the required picture or video.

Search Phone

You can search for files and other items stored on your Toshiba phone in the **My Documents** folder or on a storage card.

You can search by file name or by keywords located in the item. For example, you can search e-mail messages, notes, appointments, contacts, and tasks as well as in **Help**.

To search for a file or an item:

1. Access **Search Phone**.
2. In the **Search for:** field, enter the file name, word, or other information you require.
3. If you have searched for an item before, tap the arrow to the right of the **Search for:** field to find it in the searching history.
4. In the **Type:** field, select a data type to help narrow your search.
5. Tap **Search**.

In the **Results** list, you can tap the item you require to open it.



Applications and multimedia

SIM Toolkit

When you install a SIM card that has applications loaded on it, you can run the applications using the **SIM Toolkit** application.

To run an application from the SIM card:

1. Access **SIM Toolkit**. The list of SIM applications is displayed.
2. Select the application that you want to run, then tap **Select**.

 **NOTE:** The **SIM Toolkit** icon () is not displayed when the installed SIM card does not have any applications loaded. The title of this icon depends on the title of the SIM. It will generally show the name of your service provider.

Tasks

With the **Tasks** application, you can create one-off tasks or recurring tasks. You can also set reminders for your tasks, and organise them by category.

Overdue tasks will be displayed in red.

Creating a task

To create a new task:

1. Access **Tasks**.
2. Tap **Menu > New Task**.

 **TIP:** You can also create a task by entering a name for the task in the **Tap here to add a new task** field. However, using this method you will need to add the details of the task separately.

3. Edit the details of the task as required.
4. Tap the **X/OK key** or **OK**.

Applications and multimedia



TIP: You can synchronise tasks on your Toshiba phone with your PC. This will keep tasks up to date in both locations.

If you create a new task with a reminder on your PC and then synchronise tasks with your phone, the reminder is activated at the time set on your PC.

Changing the status of a task

When a new task is created, it will be set as active. When you have completed the task, you can update its status.

To mark a task as completed:

1. Access **Tasks**.
2. Scroll to the required task, then tap **Complete**.



TIP: If you need to reactivate a task, scroll to the required task, then tap **Activate**.

Video Editor

Video Editor enables you to easily edit videos. You can also create video clips by combining still images, or create a video storyboard by mixing video, photos, text and music.

Windows Live

Windows Live gives access to searching using **Live Search**.

Applications and multimedia

Windows Media

Overview of Windows Media Player 10 Mobile

You can use Windows Media Player 10 Mobile to play digital audio and video files that are stored on your Toshiba phone, a storage card or on the Internet.

Overview of screens and menus

Windows Media Player 10 Mobile has three primary screens:

- **Library** screen - enables quick access of files and playlists. It also includes an item that enables you to switch to the **Now Playing** screen.

To switch to the **Playback** screen from the **Library** screen, tap the **X/OK key** or **OK**.

The **Library** screen will be the default screen displayed when you first use Windows Media Player Mobile.

- **Now Playing** screen - displays the **Now Playing** playlist. This shows the file currently playing, as well as any files that are queued up to play next.
- **Playback** screen - displays the playback controls and the video window. You can change the appearance of this screen by selecting a different skin.

Applications and multimedia

Playing items stored on your Toshiba phone

Use the **Library** to find and play music, videos, and playlists that are stored on your Toshiba phone or storage card.

To play an item stored on your Toshiba phone:

1. Access **Windows Media**.
2. If the item is in the **Library**, scroll to the item, then tap **Play**.

If the item is not in the **Library**, tap **Menu > Open File....** Scroll to the item, then tap **Play**.



TIP: To add files to the **Library**, tap **Menu > Update Library....**

Playing items stored on a network

To play an item stored on a network:

1. Access **Windows Media**.
2. From the **Library** screen, tap **Menu > Open URL....**
3. Enter the URL of the file, then tap **OK**, or select a URL from the **History:** field.



NOTE: To play an item on a network, your Toshiba phone must connect to the network. For more information about connecting your phone to a network, see **Internet connections** in **Connectivity**.

Connectivity

Wireless Manager

Wireless Manager enables you to easily switch the **Phone**, **Bluetooth** and **Wi-Fi** functionality on or off.

 **NOTE:** You can conserve battery power by switching off **Bluetooth** and **Wi-Fi** when they are not in use.

Switching radio transmission on/off

You can switch the telephony radio transmission of your Toshiba phone on and off.

When the radio transmission is off, it is in '**Flight Mode**'. In this mode, you will not be able to make or receive calls, send or receive messages, or access the Internet.

To switch radio transmission on/off:

From **Wireless Manager**, tap the **Phone** item. Radio transmission will toggle on or off.

Bluetooth

Bluetooth is a short-range wireless communications technology. Devices with Bluetooth capabilities can exchange data over a distance of approximately 10 metres without requiring a wired connection.

Bluetooth on your Toshiba phone has three modes: **Off**, **On** and **Visible**.

In **Off** mode, you cannot send or receive data using Bluetooth.

In **On** mode, your Toshiba phone can search for and connect to other devices. However, your phone will not be visible in searches by other devices.

In **Visible** mode, your Toshiba phone can search for and connect to other devices. Your phone will also be visible to other devices.

Changing Bluetooth mode

By default, Bluetooth is in **Off** mode. Bluetooth will remain in the same mode when turning your Toshiba phone off and on.

Connectivity

To change Bluetooth mode:

1. Access **Bluetooth**.
2. Tab the **Mode** tab.
3. To set **Bluetooth** to **Off** mode, untick the **Turn on Bluetooth** checkbox.

To set **Bluetooth** to **On** mode, tick the **Turn on Bluetooth** checkbox.

To set **Bluetooth** to **Visible** mode, tick both the **Turn on Bluetooth** and **Make this device visible to other devices** checkboxes.



TIP: You can also toggle Bluetooth mode using **Wireless Manager**.

Pairing devices

When devices are paired, a relationship is created that enables the exchange of data between the devices.

The pairing can be set up using a passcode, which will ensure that exchanged data is kept secure.

Pairing of devices only needs to be carried out once. After this, the devices can connect to

each other and exchange data without the passcode needing to be entered again.

Before pairing your Toshiba phone with another device, ensure that:

- Your Toshiba phone and the other device are within 10 metres of each other.
- Bluetooth on your Toshiba phone is set to **On** or **Visible**.
- Bluetooth on the other device is set to **Visible**.

To pair your Toshiba phone with another device:

1. Access **Bluetooth**.
2. On the **Devices** tab, tap **Add new device....** Your Toshiba phone will search for other Bluetooth-enabled devices and display them in a list.
3. Tap the required device, then tap **Next**.
4. For enhanced security, enter a passcode in the **Passcode:** field. This is alphanumeric, and can be between 1 and 16 characters in length.
5. Tap **Next**.

Connectivity

6. Wait for the other device to accept the pairing. If a passcode has been set on your Toshiba phone, then it will need to be entered on the other device.
7. To edit the settings for the device, tap **Advanced**. You can then edit the name to be used for the device, and select services to use from the device. Tap **Save** when you have finished.
To finish the pairing without editing the settings, tap **Done**.

Connecting a Bluetooth headset

Before connecting a Bluetooth headset to your Toshiba phone, ensure that:

- Bluetooth on your Toshiba phone is set to **Visible**.
- the Bluetooth headset is set to pairing mode.

To connect a Bluetooth headset:

1. Access **Bluetooth**.
2. On the **Devices** tab, tap **Add new device....**
3. Tap the Bluetooth headset in the list of

devices, then tap **Next**.

4. Enter the passcode for the headset. This will be provided with your Bluetooth headset.
5. Tap **Next**.
6. Wait for the headset to accept the pairing.
7. A confirmation will be displayed when the headset has been connected. Tap **Advanced**.
8. If required, edit the name of the headset.
9. Make sure that the **Hands Free** checkbox is ticked. If you are using a stereo Bluetooth headset, also make sure that the **Wireless Stereo** checkbox is ticked.
10. Tap **Save** when you have finished.

Bluetooth security

Although your Toshiba phone has security features compliant with the Bluetooth standard specification, this security might not work properly when using your Toshiba phone in a non-secure environment. Take care when using the Bluetooth feature.

Connectivity

Beam

The term '**Beam**' is used to describe the short range transfer of data between two devices via a Bluetooth connection.

You can beam **Calendar**, **Contacts**, **Tasks**, and **Pictures & Videos** items, and other files stored on your Toshiba phone, to other devices.



NOTE: Bluetooth must be set to **On** or **Visible** to send beamed items.

To receive beamed items, Bluetooth must be set to **Visible**.

Beaming an item

To beam an item to another device:

1. Scroll to the item that you want to beam, then tap **Menu > Beam...** (This path will vary slightly depending on the type of item that you want to beam.).
2. Tap the device to which you want to send the item.

Configuring your Toshiba phone to receive beamed data

To configure your Toshiba phone to receive beamed data:

1. Access **Beam**.
2. Tick the **Receive all incoming beams** checkbox, then tap the **X/OK key** or **OK**.

Connectivity

Internet connections

Your Toshiba phone is equipped with powerful networking functions that enable you to connect to the Internet through a General Packet Radio Service (GPRS) or Universal Mobile Telecommunications System (UMTS) network. You can set up connections to the Internet or to a corporate network to browse the Internet, and exchange e-mail or instant messages.

If your Toshiba phone has not been preconfigured, you will need to manually enter the details for the required internet connections. For details of setting up internet connections, see **Annex 5 - Configuring internet settings**.

Domain Enroll

Domain Enroll enables you to enroll your Toshiba phone as a domain member. You can then connect your phone securely to a network, e.g. your work network.

Internet Sharing

Internet Sharing enables you to use your Toshiba phone as a modem for a PC.



NOTE: This functionality is only available if it is supported on your SIM card.

To connect to the Internet using **Internet Sharing**:

1. Connect your Toshiba phone to a PC using the USB cable or Bluetooth.
2. Access **Internet Sharing**.
3. In the **PC Connection:** field, select the type of connection used for connecting the phone and PC.
4. In the **Network Connection:** field, select the connection to use to connect to the Internet.
5. Tap **Connect**. Once the connection is enabled, you can access the Internet on a PC using your Toshiba phone as a modem.
6. When you have finished using the Internet, tap **Disconnect** on your phone.

Connectivity

USB to PC

USB to PC enables you to change the type of USB connection used between your Toshiba phone and PC.

Wi-Fi

Your Toshiba phone supports Wi-Fi (Wireless LAN), which is IEEE 802.11b/g compliant.

Connecting to a Wi-Fi network

Before connecting to a Wi-Fi network, ensure that Wi-Fi on your Toshiba phone is on.

To connect to a Wi-Fi network:

1. Access **Easy Connection**.
2. Tap **Wi-Fi Settings**.
3. Tap the required network, then tap **Connect**
or
add a new network by tapping **Add New** and entering the details of the network.



TIP: You can also connect to a Wi-Fi network from the **Wi-Fi** settings.

Wi-Fi security

It is possible for an outside party to easily gain unlawful access to your Toshiba phone via Wi-Fi if the security function is not used.

Without this security, your Toshiba phone carries the risk of unlawful access, wiretapping, and loss or destruction of data.

You should set up your Toshiba phone to use the authentication and encryption features in order to prevent such access.

Settings

Volume control

You can access the phone sound volume and ringer/call volume settings by tapping the ringer icon on the title bar.

Volume control has the following settings:

- Phone sound volume - 6 levels.
- Ringer/call volume - 6 levels.
- Both phone volume and ringer/call volume can be set to **On**, **Vibrate** or **Off**.



TIP: You can change the volume settings by pressing the **Volume keys**.



TIP: You can also change the phone volume and ringer/call volume settings using **Toshiba Volume Settings**. To do this:

1. Access **Volume Settings**.
2. Tap the required setting (**On**, **Vibrate** or **Off**), then tap **OK**.

Location Request

Location Request sets the action of your Toshiba phone when there is a location request from the third party.

Settings

Security settings

It is advisable to apply certain security features in case your Toshiba phone is lost or stolen.

You can apply the following security to prevent unauthorised use:

- **Device lock** - when this feature is activated, you will need to unlock the phone before you can use it.

You can enable a password for the device lock to prevent unauthorised use of your Toshiba phone. You can also set a time after which the device lock will be activated if the phone is left idle.

When the device lock is activated with a password enabled, you will be prompted to enter the password to unlock the phone.

By using the device lock without a password, you can prevent accidental calls and operations.

- **Phone lock** - using a personal identification number (PIN), this feature prevents unauthorised use of your SIM card in any phone. When this feature is activated, you

will be prompted for your PIN when you switch on your Toshiba phone. You cannot use the SIM card until the PIN is entered correctly.

- **SIM Lock** - this feature prevents unauthorised use of your Toshiba phone with other SIM cards. When this feature is activated, your Toshiba phone can only be used with the SIM card that was in the phone during **SIM Lock** activation.
- **Keypad lock** - this feature prevents accidental calls and operations.

Enabling a password for the device lock

To enable a password for the device lock:

1. Access **Lock**.
2. On the **Password** tab, tick the **Prompt if device unused for** checkbox, and select how long your device can be left idle before a password is required.
3. Select a password type.
4. Enter and confirm a password.

Settings

5. Enter a hint on the **Hint** tab if required.
6. Tap the **X/OK key** or **OK**.
7. Tap **Yes** to confirm the changes.

 **IMPORTANT:** If you forget your password, you will need to reinitialise your phone. See **Master Clear** for details.

Disabling the device lock password

To disable the device lock password:

1. Access **Lock**.
2. Enter your current password, then tap **Unlock**.
3. On the **Password** tab, untick the **Prompt if device unused for** checkbox.
4. Tap the **X/OK key** or **OK**.
5. Tap **Yes** to confirm the change.

Activating the device lock



To activate the device lock, enter the sleep mode or tap **Start** and **Lock** (left softkey).

Deactivating the device lock

The device lock will be activated when returning from the sleep mode.

To deactivate the device lock:

If the device lock password is enabled,

1. Slide the  to the right or left when it appears.
2. Enter your current password.
3. Tap  or **Unlock** to return to where you left off,



to go to **Contacts**, or



to go to **Messaging**.

If the device lock password is not enabled, slide the  to the left or right.

Enabling phone lock



NOTE: Before you start, you will need to know the SIM PIN. This is provided with your SIM card.

To enable the phone lock:

1. Access the **Phone** settings.
2. Tap the **Security** tab.

Settings

3. Tick the **Require PIN when phone is used** checkbox.
4. Enter the SIM PIN, then tap **Enter**.
5. Tap the **X/OK key** or **OK**.

Disabling phone lock

To disable the phone lock:

1. Access the **Phone** settings.
2. Tap the **Security** tab.
3. Untick the **Require PIN when phone is used** checkbox.
4. Enter the SIM PIN, then tap **Enter**.

 **WARNING:** If you enter the incorrect PIN for your SIM card three consecutive times, you will need to contact your service provider to obtain the PUK. Do not try to guess the PUK as your SIM card will be rendered permanently inoperative following ten consecutive unsuccessful attempts.

5. Tap the **X/OK key** or **OK**.

Settings

Activating SIM Lock

To activate **SIM Lock**:

1. Access **SIM Lock**.
2. Tick the **Lock phone to use current SIM card only** checkbox.
3. Enter and confirm a password of eight digits.
4. Tap **Done**, the **X/OK key** or **OK**.
5. Tap **Yes** to confirm the changes.

Deactivating SIM Lock

To deactivate **SIM Lock**:

1. Access **SIM Lock**.
2. Enter the **SIM Lock** password, then tap **Done**, the **X/OK key** or **OK**.
3. Untick the **Lock phone to use current SIM card only** checkbox.
4. Tap **Done**, the **X/OK key** or **OK**.
5. Tap **Yes** to confirm the changes.

Customising the Toshiba Menu

To customise the **Toshiba Menu**:

1. From the **Toshiba Home Screen**, tap **Menu**.
2. Select the required settings from the following:
 - tap **Change Stripes** to change the order and colours of the stripes.
 - tap **Thumbnail Settings** to select the thumbnails for each stripe.
3. Tap **OK** when you have finished.

Owner Information

Owner Information enables you to enter contact information so that your phone can be easily returned if it is lost.

Settings

Phone settings

Setting ring tones

To set a ring tone:

1. Access the **Phone** settings.
2. On the **Phone** tab, select the following:
 - In the **Ring type:** field, select the required type of tone. This can be ringing, vibration, a combination of ringing and vibration, or none.
 - In the **Ring tone:** field, select the required tone.



TIP: Tap the play icon to listen to a sample of the selected ring tone.

3. Tap the **X/OK key** or **OK**.



TIP: You can use custom sounds as ring tones. You can copy the files to your phone from your PC using **ActiveSync**, or download them from the Internet.



TIP: You can also set the ring tone from the **Sounds & Notifications** settings.

Setting keypad tones

To set keypad tones:

1. Access the **Phone** settings.
2. On the **Phone** tab, select the required type of keypad tones in the **Keypad:** field. To have no keypad tones, select **Off**.

Call Barring

Call Barring enables you to block certain categories of incoming and outgoing calls (for example, international calls).



NOTE: **Call Barring** is only available if it is supported by your service provider.



NOTE: Before setting up **Call Barring**, you will need to obtain your call barring password from your service provider.

To set up **Call Barring**:

1. Access the **Phone** settings.
2. Tap the **Services** tab.
3. In the list of services, tap **Call Barring**, then tap the **Get Settings...** button. The settings will then be read from the network.

Settings

4. When the current settings are displayed, select the settings required for blocking incoming and outgoing calls.
5. Tap the **X/OK key** or **OK**.
6. Enter the call barring password, then tap the **X/OK key** or **OK**. The settings are sent to the network.

Caller ID

Caller ID allows selected call recipients to view your name and phone number information on their phone when you call them.

To configure **Caller ID**:

1. Access the **Phone** settings.
2. Tap the **Services** tab.
3. In the list of services, tap **Caller ID**, then tap the **Get Settings...** button.
4. In the **Provide my caller ID to:** field, select one of the following:
 - **Everyone** - your information will be displayed to everyone that you call.
 - **No one** - your information will be hidden from everyone that you call.

- **Only to contacts** - your information will only be displayed when you call a number stored in **Contacts**.

5. Tap the **X/OK key** or **OK**.

Call Forwarding

Call Forwarding enables you to forward incoming calls to another number.



NOTE: **Call Forwarding** is only available if it is supported by your service provider.

To set up **Call Forwarding**:

1. Access the **Phone** settings.
2. Tap the **Services** tab.
3. In the list of services, tap **Call Forwarding**, then tap the **Get Settings...** button.
4. Select the conditions during which you would like to forward incoming calls. Enter the phone number(s) for forwarded calls.



TIP: If you have set up voice mail, you can select **Voice mail** as the phone number for forwarded calls. For details of setting up voice mail, see **Setting up voice mail**.

Settings

5. Tap the **X/OK key** or **OK**.

Call Waiting

Call Waiting notifies you of incoming calls when you are already in a call. You will then have the option to answer or ignore the second call.



NOTE: Call Waiting is only available if it is supported by your service provider.

To enable **Call Waiting**:

1. Access the **Phone** settings.
2. Tap the **Services** tab.
3. In the list of services, tap **Call Waiting**, then tap the **Get Settings...** button.
4. Select whether or not you wish to be notified of waiting calls.
5. Tap the **X/OK key** or **OK**.

Setting up voice mail

Voice mail is normally preconfigured. If it is not preconfigured, you can save your voice mail number to the phone manually.

To set up voice mail manually:

1. Access **Easy Connection**.
2. Tap **Mail Settings**.
3. Tap **SMS**.
4. Enter your voice mail number in the **Voice mail number:** field. This can be obtained from your service provider.
5. Tap **OK**.

Fixed Dialing

Fixed Dialing restricts the numbers that you can call from your Toshiba phone. When **Fixed Dialing** is activated, you can only call predefined numbers or area codes. These numbers are stored in a list that you can set up and edit using your Toshiba phone.



NOTE: Fixed Dialing is only available if it is supported by your service provider.

Settings

 **NOTE:** Before setting up **Fixed Dialing**, you will need to obtain PIN2 from your service provider.

To set up **Fixed Dialing**:

1. Access the **Phone** settings.
2. Tap the **Services** tab.
3. In the list of services, tap **Fixed Dialing**, then tap the **Get Settings...** button.
4. Tick the **Enable fixed dialing** checkbox.
5. Tap **Menu > Add**.
6. In the **Add or change the number pattern:** field, enter the phone number or area code you want to be able to call.
7. Tap **Done**.
8. If required, add more numbers, then tap **Done**.
9. Enter PIN2, then tap **Done**.

Setting the network selection type

 **NOTE:** This setting is only available if it is supported by your service provider.

To set the network selection type:

1. Access the **Phone** settings.
2. Tap the **Network** tab.
3. In the **Network selection** field, select **Automatic** or **Manual** as required.
4. If you select **Automatic**, your Toshiba phone will register to the default network. This network is defined by your SIM card.
5. If you select **Manual**, you will need to wait for the phone to search for all available networks. When the list of networks is displayed, tap the required network, then tap **OK**. Your Toshiba phone will register to the selected network.
6. Tap the **X/OK key** or **OK**.

The default setting is **Automatic**.

If you select **Manual**, and your current network becomes unavailable, you will need to wait for

Settings

the phone to search for all available networks. You can then select one to connect to.

Preferred networks

If you have selected the **Automatic** network selection type, following any failure in connection to your home network, your Toshiba phone will attempt to connect to the first network in the list of **Preferred networks**. If this fails, the phone will attempt to connect to the next network in the list, and so on.

To set up or update the list of **Preferred networks**:

1. Access the **Phone** settings.
2. Tap the **Network** tab.
3. Tap **Set Networks**. The settings will then be read from the network.
4. Add new networks or reorder the list as required. You can also remove networks from the list by unticking the checkbox beside the network name.
5. Tap the **X/OK key** or **OK** when you have finished.

Connecting to a network

To connect to a network:

1. Access the **Phone** settings.
2. Tap the **Network** tab.
3. Tap **Find Network**. You will need to wait for the phone to search for all available networks.

When the list of networks is displayed, tap the required network, then tap **OK**. Your Toshiba phone will register to the selected network.

Setting network mode

To set the network mode:

1. Access the **Phone** settings.
2. Tap the **Mode** tab.
3. Select a network mode from one of the following:
 - **Automatic** - selects network mode automatically.
 - **HSDPA** - selects 3G/3.5G network mode.
 - **GSM** - selects 2G/2.5G network mode.
4. Tap the **X/OK key** or **OK**.

Settings



NOTE: Changing the network mode settings may limit the ability of your Toshiba phone to connect to the wireless network, and may result in signal failure.

Sounds & Notifications

You can set a different sound for different events. The sound can be set to something different for each type of event.

You can also set up the sounds and vibrations required when tapping the screen.

Setting sounds and notifications

To set sounds and notifications:

1. Access **Sounds & Notifications**.
2. On the **Sounds** tab, select the required settings from the following:
 - Tick the **Events** checkbox to enable sounds for events such as warnings.
 - Tick the **Programs** checkbox to enable sounds for applications.
 - Select whether to enable sounds for **Screen taps** or pressing **Hardware buttons**. You can also specify the level of the sounds.
3. On the **Notifications** tab, select the specific sound required for each event, and the way in which you want to be notified of the event.

Settings

Available items are dependent on the event selected.



TIP: Tap the play icon to listen to a sample of the selected sound.



TIP: You can use custom sounds by copying the files to your phone from your PC using **ActiveSync**, or downloading them from the Internet.



TIP: Disabling sounds and flashing lights for events will help to conserve battery power.

4. On the **Vibrations** tab, select whether to activate vibrations for screen taps. You can also specify the length of the vibrations.
5. Tap the **X/OK key** or **OK** when you have finished.

About

The **About** setting enables you to view technical information about your Toshiba phone, including the operating system and memory of the phone. This information is useful when installing new applications on your Toshiba phone.

You can also change the name of your Toshiba phone as it is displayed to other devices (for example, when using Bluetooth).

Changing device name

To change the device name:

1. Access **About**.
2. Tap the **Device ID** tab.
3. Enter a new name for your Toshiba phone in the **Device name:** field. You can also add a description if required.
4. Tap the **X/OK key** or **OK**.

Settings

Adjust Motion Sensor

If the **Motion Sensor** does not seem to be operating correctly, you can adjust it as follows:

1. Place your Toshiba phone on a stable, level surface, with the touch screen facing upwards.
2. Access **Adjust Motion Sensor**.
3. If the yellow circle is not in the centre of the target area, tap **Adjust**.
4. When the adjustment is complete, tap **OK**.

Backlight settings

You can adjust the brightness of the backlight, and set the backlight to dim after a specific amount of time has elapsed.

You can configure settings to prolong battery power.

To change the backlight settings:

1. Access **Backlight**.
2. On the **Battery Power** tab, you can select when to turn off the backlight when using battery power.
3. On the **External Power** tab, you can select when to turn off the backlight when using external power.
4. On the **Brightness** tab, you can adjust the brightness of the screen when using battery or external power.
5. Tap the **X/OK key** or **OK** when you have finished.



NOTE: The higher the brightness, and the longer the backlight remains on, the more power will be used.

Settings

Browser Settings

Browser Settings enables you to set **Internet Explorer** as a high speed browser.

 **NOTE:** Using the high speed browser setting will increase battery consumption, and may increase the time taken to switch your Toshiba phone on/off.

Certificates

To view certificate details:

Access **Certificates**. On each tab, the certificate names, along with their issuing authority and expiry date, are displayed. Tap a certificate to view its details.

Clock & Alarms

Setting the date and time

To set the date and time:

1. Access **Clock & Alarms**.
2. Tap **Time** tab if required.
3. In the **Home** section, you can set the time zone, current time and date for when you are at home.
4. In the **Visiting** section, you can set the time zone, current time and date when visiting another country or time zone.
5. Tap the **X/OK key** or **OK** when you have finished.
6. Tap **Yes** to save the changes.

 **NOTE:** These settings are only lost if you reset your Toshiba phone. Your settings are saved if you power off the phone, or if the battery is fully discharged.

Setting an alarm

To set an alarm:

1. Access **Clock & Alarms**.

Settings

2. Tap the **Alarms** tab.
3. Tap the letters below the < **Description** > field to select the days when the alarm is required.
4. Tap the time display on the right to set a time for this alarm, then tap the **X/OK key** or **OK**.
5. Tap the bell icon to select the types of alarm to use.
6. Tap the **X/OK key** or **OK** twice.

Additional clock and alarm settings

To set the clock to be displayed on the title bar in all programs:

1. Access **Clock & Alarms**.
2. Tap the **More** tab.
3. Tick the **Display the clock on the title bar in all programs** checkbox.
4. Tap the **X/OK key** or **OK**.

To set alarms to be audible even when the phone is set to silent or vibrate:

1. Access **Clock & Alarms**.
2. Tap the **More** tab.

3. Tick the **Sound alarms even when the device is set to silent or vibrate** checkbox.
4. Tap the **X/OK key** or **OK**.

Customer Feedback

Customer Feedback sends anonymous information to Microsoft for use in helping improve Windows Mobile software.

Encryption

This feature allows you to secure sensitive information on your storage card. The data will only be accessible when the card is installed in your Toshiba phone. If the card is lost or stolen, the information remains secure. The contents of the storage card cannot be accessed by anyone else because they are encrypted.

To encrypt the contents of your storage card:

1. Access **Encryption**.
2. Tick the **Encrypt files when placed on a storage card** checkbox.

Settings

3. Tap the **X/OK key** or **OK**.

 **WARNING:** Anyone in possession of the encryption key can decrypt and access information stored on the storage card.

Error Reporting

Error Reporting sends data from your Toshiba phone to Microsoft technical support groups. The data is used to diagnose program errors for devices running Windows Mobile software.

If a program error occurs, **Error Reporting** starts automatically. The information Microsoft receives is used by programming groups at Microsoft. The data is used for quality control and will not be used for tracking individual users, installations or for any marketing purpose.

External GPS

To set up **External GPS**:

1. Access **GPS Settings**.
2. On the **Programs** tab, select the port that your Toshiba phone will use to obtain GPS data.
3. On the **Hardware** tab, select the hardware port to which your GPS device is connected. You can also set the baud rate.
4. On the **Access** tab, tick the **Manage GPS automatically (recommended)** checkbox if required. You are strongly advised to use this feature as it will enable Windows Mobile to manage access to your GPS device, and allows multiple programs to obtain GPS data simultaneously.
5. Tap the **X/OK key** or **OK** when you have finished.

Settings

Free Pad Settings

Enabling and disabling Toshiba Free Pad

To enable/disable the **Toshiba Free Pad**:

1. Access **Free Pad Settings**.
2. Tick or untick the **Use Toshiba Free Pad** checkbox as required.
3. Tap **OK**.

Setting up Toshiba Free Pad for left or right-handed use

To set up **Toshiba Free Pad** for left or right-handed use:

1. Access **Free Pad Settings**.
2. Ensure that the **Use Toshiba Free Pad** checkbox is ticked.
3. Select **Right-handed** or **Left-handed** as required.
4. Tap **OK**.

Internal GPS

Internal GPS enables you to change the settings for downloading the latest satellite data from the network and detecting position information quickly.

Managed Programs

Managed Programs lists applications that have been installed remotely by your company system administrator. You can view details of these applications.

Settings

Master Clear

Master Clear resets all settings on your Toshiba phone to their factory defaults, and deletes all of your data.

You should only use this procedure as a last resort. It is recommended that you back up all of your data before using **Master Clear**.

If you are experiencing a problem with an application, it is most likely a result of a conflict between installed programs. We recommend uninstalling the most recently added program first. Also verify that the program is designed to be run on your Toshiba phone by comparing the requirements to the information provided with your phone. To view this information, access **About**.

To reinitialise your Toshiba phone when it is switched on:

1. Access **Master Clear**.
2. Follow the on-screen instructions to reinitialise your phone. The phone will restart after it has been reinitialised.

To reinitialise your Toshiba phone if there are problems in accessing the **Master Clear** application:

1. Press and hold the **Power key**, the **Volume Up key** and the **Camera key** until the **Master Clear** screen is displayed (at least five seconds).
2. Within 60 seconds, press the **Volume Down key** to select < **Yes** > for the on-screen confirmation, then press the **Camera key**.
3. Press the **Volume Down key** to select < **Yes** > for the on-screen final confirmation, then press the **Camera key**. The phone will restart after it has been reinitialised.

Settings

Memory management

To ensure optimum performance of your Toshiba phone, it is necessary to maintain sufficient memory.

To check the memory available on your Toshiba phone:

1. Access **Memory**.
2. On the **Main** tab, you can view the details of **Storage** and **Program** memory.
3. On the **Storage Card** tab, you can view the memory available on the storage card.
4. Tap **Find large files using storage memory**. to search for specific files.

Motion Sensor Settings

These settings will allow you to select whether the motion sensor is activated when you shake or tap your Toshiba phone.

Power settings

The **Power** settings enable you to check the battery status and configure settings to prolong battery power.

To view and change **Power** settings:

1. Access **Power**.
2. On the **Battery** tab, the remaining battery power is displayed.
3. On the **Advanced** tab, you can select when to turn off the phone when using battery or external power.
4. On the **Wi-Fi** tab, you can restrict sleep mode activation, and set the power save setting to use when Wi-Fi is on.
5. Tap the **X/OK key** or **OK** when you have finished.

Power Saving Settings

Power Saving Settings enables you to set up your Toshiba phone to optimise performance or save battery power, depending on your preferences.

Settings

Regional Settings

Regional Settings enables you to specify the styles in which numbers, currency, time and date are displayed.

To change **Regional Settings**:

1. Access **Regional Settings**.
2. On the **Region** tab, select your region in the drop-down list. Changing this setting automatically updates the styles in which numbers, currency, time and date are displayed to the defaults for the selected region.
3. Change specific items on the other tabs if required.
4. Tap the **X/OK key** or **OK** when you have finished.

Remove Programs

Remove Programs enables you to delete applications that you have installed.



NOTE: Programs that were pre-installed on your Toshiba phone cannot be removed in this way.

To remove a program:

1. Access **Remove Programs**.
2. Tap the application to remove, then tap **Remove**.
3. Tap **Yes** to confirm the deletion.
4. Tap the **X/OK key** or **OK** when you have finished removing programs.

Settings

Screen settings

Adjusting screen settings

To adjust screen settings:

1. Access **Screen**.
2. On the **General** tab, you can set up the screen orientation and alignment.
3. On the **ClearType** tab, you can enable ClearType, which smooths the edge of screen fonts.
4. On the **Text Size** tab, you can slide the marker to adjust the text size. An example of the selected text size is displayed.
5. Tap the **X/OK key** or **OK** when you have finished.

Adjusting scroll speed

The scroll speed is the speed at which you can scroll through items in a list.

To adjust the scroll speed:

1. Access **Buttons**.
2. In the **Delay before first repeat:** field, move the pointer to adjust the time taken

before scrolling begins.

3. In the **Repeat rate:** field, move the pointer to adjust the time taken to scroll from one item to the next.
4. Tap the **X/OK key** or **OK** when you have finished.

Settings

Task Manager

Task Manager enables you to quickly switch between currently running applications.

It also enables you to end an application if it becomes unstable or the memory is low.

Switching between applications

To switch between applications using **Task Manager**:

1. Access **Task Manager**.
2. Double-tap on the application to access.



TIP: Alternatively, tap the application, then tap **Menu > Switch To**.

Ending applications

To end an application using **Task Manager**:

1. Access **Task Manager**.
2. Tap the application to end, then tap **End Task**. To end all running applications, tap **Menu > End All Tasks**, then tap **Yes** to confirm the action.
3. Tap **Menu > Exit** when you have finished.

Video Quality Setting

This setting enables you to set the quality for playing video files.

Sleep Mode Indicator

This setting enables you to set the LED indicator to be on when your Toshiba phone is in sleep mode.

Operator Name Setting

This setting enables you to select whether the operator name is displayed on the **Toshiba Home Screen**.

Specifications

System Information	
Processor	Qualcomm® Snapdragon™ QSD8250, Scorpion™ at 1 GHz
Memory	RAM : 256 MB ROM : 512 MB
Operating System	Windows Mobile® 6.5 Professional
UMTS/HSDPA/HSUPA GSM/GPRS/EDGE Frequency Range	
Within 3G (UMTS) 2100	1920 - 2170 MHz
Within GSM 850	824 - 894 MHz
Within GSM 900	880 - 960 MHz
Within DCS 1800	1710 - 1880 MHz
Within PCS 1900	1850 - 1990 MHz
Continuous Talk Time	
Within 3G (UMTS) area	Approximately 240 minutes
Within GSM area	Approximately 275 minutes
Continuous Standby Time	
Within 3G (UMTS) area	Approximately 220 hours
Within GSM area	Approximately 225 hours

Specifications

Maximum Output	
Within 3G (UMTS) 2100	Class 3 0.25 W
Within GSM 850	Class 4 2 W
Within GSM 900	Class 4 2 W
Within DCS 1800	Class 1 1 W
Within PCS 1900	Class 1 1 W
Dimensions (H x W x D)	
Approximately 130 mm x 70 mm x 9.9 mm	
Weight	
Approximately 129 g	
AC Charger	
Input voltage	100 to 240 VAC, 50/60 Hz
Charging temperature range	5 to 35 °C
Battery charging time	Approximately 140 minutes
Display	
LCD	4.1" TFT LCD with Touch screen
Resolution	800 x 480 (65536 colours)

Specifications

Audio/Video codecs	
Audio	AAC, AAC+, eAAC+, AMRNB, MP3, WMA
Video	ASF, H.263, H.264, MPEG-4, WMV
Connectivity	
Bluetooth	Bluetooth™ ver2.0 + EDR (Power Class 2) Advanced Audio Distribution Profile (A2DP) Audio/Video Remote Control Profile (AVRCP) Generic Access Profile (GAP) Hands-Free Profile (HFP) Headset Profile (HSP) Personal Area Networking Profile (PAN) Phone Book Access Profile (PBAP) Serial Port Profile (SPP)
Wireless LAN	IEEE 802.11b/g AES, TKIP, WEP, WPA, WPA-PSK, WPA2, WPA2-PSK
Interface	
Cable, headset and phone charging	Micro-USB (Client, Full Speed, High Speed, Host) / Headset / Charger
Headset Connector	Micro-USB stereo headset
Expansion slot	microSD™

Troubleshooting

Problem	Possible cause	Possible solution
Cannot switch phone on.	Battery out of power.	Charge the battery (see page 32).
	Battery not installed correctly.	Ensure that the battery is inserted correctly (see page 30).
Phone switches off automatically.	Battery out of power.	Charge the battery (see page 32).
Cannot charge battery.	Battery not installed correctly.	Ensure that the battery is inserted correctly (see page 30).
	AC charger not connected.	Ensure that the AC charger is connected to the phone and to a working AC outlet.
	Connectors are dirty.	Clean the connectors of the AC charger and battery.
	Battery has worn out.	Replace the battery.
	Battery or AC charger is damaged.	Replace the battery or charger. Contact your dealer for assistance.
Battery loses power quickly.	Backlight and Power settings need to be adjusted.	Adjust settings to optimise power performance (see page 94 and page 100).

Troubleshooting

Problem	Possible cause	Possible solution
Network not displayed.	SIM card not installed correctly.	Ensure that the SIM card is inserted correctly (see page 28).
	Contacts between SIM card and phone are dirty.	Gently clean the contacts of the SIM card and phone.
	Network signal is weak.	Move clear of any obstructions that may block the signal.
	SIM card is damaged.	Contact your service provider to obtain a replacement SIM card.
Cannot make a call.	You are outside of your network service area.	Connect to a different network if this is supported by your service provider (see page 91).
	Phone or SIM card is locked.	Unlock the phone or SIM card (see page 83).
	Call Barring is active.	Deactivate Call Barring (see page 87).
Cannot answer a call.	Call Forwarding is active.	Deactivate Call Forwarding (see page 88).
	Call Barring is active.	Deactivate Call Barring (see page 87).
No ringing for an incoming call.	Phone is set to not ring for incoming calls.	Edit the ringtone settings (see page 87).

Troubleshooting

Problem	Possible cause	Possible solution
Poor call quality.	Network signal is weak.	Move clear of any obstructions that may block the signal.
	Network signal is changing frequently, e.g. when travelling on a train.	Wait until signal strength is consistently high before making or answering a call.
Other party in a call cannot hear you.	Phone is muted.	Unmute the phone (see page 46).
Cannot send or receive text messages.	Your service provider is not enabling this service.	Contact your service provider to check your subscription status.
Cannot send or receive MMS messages.	Your service provider is not enabling this service.	Contact your service provider to check your subscription status.
	MMS settings are missing or incorrect.	Ensure that the MMS settings are correct (see page 126). To obtain the settings, contact your service provider.
Cannot access the Internet.	Your service provider is not enabling this service.	Contact your service provider to check your subscription status.
	Network settings are missing or incorrect.	Ensure that the network settings are correct (see page 80). To obtain the settings, contact your service provider.

Troubleshooting

Problem	Possible cause	Possible solution
Storage memory is low.	Too many items stored on the phone.	Delete any unwanted messages, clear the Internet history, and delete any unwanted files.
Storage card is not recognised.	Storage card not installed correctly.	Ensure that the storage card is inserted correctly (see page 28).
	Storage card is damaged.	Replace the storage card.

Annex 1 - Text input

Input methods

Your Toshiba phone enables you to enter information in three different ways:

- Typing - using the **Input Panel**.
- Writing - using the stylus, writing directly on the screen.
- Drawing - using the stylus, drawing directly on the screen.

Input Panel

The **Input Panel** provides the following input methods:

- **Block Recognizer**
- **Keyboard**
- **Letter Recognizer**
- **Toshiba Keyboard**
- **Transcriber**

The **Input Panel** icon is displayed at the centre bottom of the screen when text input is possible.

To open the **Input Panel**, tap the **Input Panel** icon. You can then tap the arrow beside the icon to select other input methods.

When you begin entering a word using any of the input methods except **Transcriber**, your Toshiba phone will suggest possible words. Tap one of the suggested words to enter it.

Your Toshiba phone will learn words as you use them. They will then be used as suggested words in the future.

Block Recognizer

With **Block Recognizer**, you use a single stroke to write individual letters, numbers and punctuation, which are then converted into typed text.

The handwriting area is divided into two designated parts: **abc** and **123**.

Write characters, numbers, symbols and punctuation in the separate areas:

- Write in the **abc** area to enter lower case letters.
- Write in the **123** area to enter numbers.
- Tap the button in the bottom right corner labelled '@\$*' to open the table of symbols and punctuation.

Annex 1 - Text input

 **NOTE: Block Recognizer** is available when text entry is possible.

 **TIP:** For help with using **Block Recognizer**, tap ? in the right corner to see a demo.

Keyboard

With **Keyboard**, you use the stylus to tap on the keyboard to enter characters.

 **TIP:** Tap áü to enter miscellaneous letters and symbols.

Letter Recognizer

With **Letter Recognizer**, you can write individual letters, numbers and punctuation, which are then converted into typed text.

The handwriting area is divided into three designated parts: **ABC**, **abc** and **123**.

Write characters, numbers, symbols, and punctuation in the separate areas:

- Write in the **ABC** area to enter upper case letters.

- Write in the **abc** area to enter lower case letters.
- Write in the **123** area to enter numbers.
- Tap the button in the bottom right corner labelled '@\$*' to open the table of symbols and punctuation.

 **NOTE: Letter Recognizer** is available when text entry is possible.

 **TIP:** For help with using **Letter Recognizer**, tap ? in the right corner to see a demo.

Toshiba Keyboard

With **Toshiba Keyboard**, you use the stylus to tap on the keyboard to enter characters.

Toshiba Keyboard consists of the following three keyboard layouts:

- **QWERTY pad** - this has a similar layout to a PC keyboard.
- **Multi-tap pad** - this has a similar layout to a conventional multi-tap mobile phone keypad.

Annex 1 - Text input

- **Numeric/Symbol pad** - this enables easy entry of numbers, symbols and special language characters.

Tap the pad switch buttons ( and  for **QWERTY pad**,  for **Multi-tap pad**,  for **Numeric/Symbol pad**) to switch between the different pads.

Transcriber

Transcriber is a handwriting recognition program that enables you to write in cursive, print, or a combination of both.

Transcriber enables you to write anywhere on the screen using the stylus, just as you would write on paper. Unlike when using **Block Recognizer** and **Letter Recognizer**, you can write entire sentences. When you pause, **Transcriber** will convert the written text to typed text.

Transcriber works transparently in the background, recognising words with its integrated dictionary. When **Transcriber** is active, it interprets stylus movement anywhere

on the screen as handwriting input.

Showing and hiding the Transcriber toolbar

The **Transcriber** toolbar provides easy access to several tools, as well as Enter, Space, and Backspace buttons, and left and right arrow buttons. It is displayed at the bottom of the screen when **Transcriber** is active.

To show or hide the **Transcriber** toolbar, tap the **Transcriber** icon at the bottom of the screen.

Using the Transcriber keyboard

Transcriber comes with an on-screen keyboard that provides an easy way to add punctuation or a special symbol to existing text. To access the **Transcriber** keyboard: Tap the keyboard button on the **Transcriber** toolbar. The keyboard is displayed until you tap the keyboard button again.



TIP: To reposition the keyboard, tap and hold the top bar, then drag it to the desired location.

Annex 1 - Text input



TIP: When no text is selected, you can open the keyboard by doing the  gesture.

Editing text with Transcriber

To edit text with **Transcriber**:

1. Draw a line across the text you want to edit. After you lift the stylus from the screen, the line will disappear and the selected text will be highlighted.
2. Do one of the following:
 - Rewrite the text.
 - Use gestures to capitalise letters, insert a space, etc.

Using gestures in Transcriber

To use gestures in **Transcriber**:

Use quick strokes of the stylus to edit your text.

Do the Enter, Space, and Tab gestures while writing text to insert returns, spaces, or tabs.

Available gestures are described in the **Overview of Microsoft Transcriber**.

Optimising handwriting recognition for Transcriber

If **Transcriber** does not recognise your handwriting as accurately or quickly as you would like, there are some things you can do to optimise handwriting recognition.

- Select the **Writing Direction**: picture that best matches the slant of your handwriting.
- Use **Letter Shapes** to eliminate letter shapes that you do not use or to learn methods of writing characters that will make them easier for **Transcriber** to recognise.
- Try writing in another format. If you have been printing, try writing cursive, or if you have been writing in both cursive and print, try printing alone.
- Adjust the speed at which **Transcriber** returns text after you write.
- Add a user dictionary that contains special terms you may be using, such as medical or legal terms.
- Verify that you are using your **Letter Shapes** user profile.

Annex 1 - Text input

Input Options

To set the input options:

1. Tap the **Input Panel** selector arrow, then tap **Options....**
2. In the **Input method:** field, select the required input method. Tap **Options...** to access the options available for the selected method. Tap the **X/OK key** or **OK** when you have finished.
3. Tap the **Word Completion** tab to change the settings for suggested words and automatic correction.
4. Tap the **Options** tab to change the general input settings, including zoom levels and capitalisation.
5. Tap the **X/OK key** or **OK** when you have finished.

Writing and drawing on the screen

With your Toshiba phone, you can draw directly on the screen, write on the screen, and save notes in your own handwriting. To do this, you must first set the input mode in **Notes** to **Writing**. If you prefer to use handwriting or frequently add drawings to your notes, you may find it helpful to set **Writing** as the default input mode. If you prefer typed text, set **Typing** as the default input mode.

To set the input mode for **Notes**:

1. Access **Notes**.
2. Tap **Menu > Options....**
3. In the **Default mode:** field, select one of the following:
 - **Writing** - if you want to draw or enter handwritten text in a note.
 - **Typing** - if you want to create a typed note.
4. Tap the **X/OK key** or **OK**.

Annex 1 - Text input

To hand write a note:

1. Access **Notes**.
2. Tap **New**.
3. Tap **Menu**, and make sure that **Draw** is ticked.
4. Write text on the screen.
5. Tap the **X/OK key** or **OK** when you have finished.

 **NOTE:** If a letter crosses three or more ruled lines, it is treated as a drawing rather than text.

To draw on the screen using the stylus:

1. Access **Notes**.
2. Tap **New**.
3. Tap **Menu**, and make sure that **Draw** is ticked.
4. Using the stylus, draw over at least three ruled lines. A box labelled **Drawing** is displayed around the drawing.
5. Tap the **X/OK key** or **OK** when you have finished.



TIP: To select a drawing (for example, to copy or delete it), tap and hold the drawing briefly. When you lift the stylus, the drawing is selected.

Annex 2 - Navigating your Toshiba phone



This section gives information about some of the main screens on your Toshiba phone. It also gives an overview of the menu structure of your phone.

Phone screen



You can access the **Phone** screen in the following ways:

- From the **Toshiba Home Screen**, tap the heading of the **Phone** menu.
- From the **Toshiba Home Screen**, tap **Start > Phone**.
- From the **Toshiba Home Screen**, tap **Phone** or .
- From the **Toshiba Free Pad** (multi function pad only), tap the **Start** icon, then tap **Phone**.

 **TIP:** When you tap a key on the numeric keypad, a list of names and/or numbers is displayed. This list shows matching names and numbers from **Contacts**, **Call History**, **Speed Dial** and the SIM card. For example, if you tap **2**, names beginning with **A**, **B** or **C** and phone numbers beginning with **2** are displayed. You can enter more characters to reduce the number of matching entries. To call an entry, tap it, then tap  or **Call**.

Annex 2 - Navigating your Toshiba phone

Accessing applications and settings

Toshiba Menu structure

Phone (Outgoing, Incoming, Contacts)

Phone screen

Settings (Wireless Manager, Alarms, Lock)

Alarms

Lock

Wireless Manager

Owner Information

Task Manager

Volume Settings

Toshiba Help

Easy Connection

Network Settings

Operator Settings

Mail Settings

Wi-Fi Settings

Toshiba Utilities

Sound Settings

Notification Settings

Motion Sensor Settings

Clock

Clock Display Setting

Sleep Mode Indicator

Video Quality Setting

Browser Settings

Power Saving Settings

Operator Name Setting

Free Pad Settings

Adjust Motion Sensor

Applications (Maps, Video Player, Contacts)

Orange Maps

Video Player

Monopoly World Demo

NFS Undercover

CorePlayer

Contacts

Excel Mobile

OneNote Mobile

PowerPoint Mobile

Word Mobile

Adobe Reader LE

Internet Explorer

Internet Sharing

Annex 2 - Navigating your Toshiba phone

Java

Messaging

PhotoBase

Pictures & Videos

Video Editor

Windows Live

Orange World (Internet, Search, TV&Video, Help, Account)

Internet Explorer

Messaging (SMS/MMS, New SMS, Email)

Messaging

Media (Help)

Windows Media

Files (My Music, My Pictures, My Videos)

File Explorer

Tools (Search, ActiveSync, Calendar)

ActiveSync

Calculator

Calendar

Notes

Search

SIM Manager

Contacts Backup



NOTE: The **Toshiba Menu** is customisable so the default menu structure has been described. For information on customising the **Toshiba Menu**, see **Customising the Toshiba Menu** in **Settings**.

Annex 2 - Navigating your Toshiba phone

Windows Mobile Start Screen structure

Start

Today

Phone

SMS/MMS

Messaging

SMS/MMS

Orange e-mail

Setup E-mail

Contacts

Internet Explorer

Calendar

Settings

Bluetooth

Clock & Alarms

Lock

Network Settings

Power

Power Saving Settings

Sounds & Notifications

Today

Wi-Fi Settings

Connections

Beam

Connections

Domain Enrollment

GPRS Settings

Mail Settings

Operator Settings

USB to PC

Wi-Fi

Wireless Manager

Personal

Buttons

Free Pad Settings

Input

Owner Information

Phone

System

About

Adjust Motion Sensor

Backlight

Browser Settings

Certificates

Customer Feedback

Annex 2 - Navigating your Toshiba phone

Encryption
Error Reporting
GPS Settings
Internal GPS Setting
Location Request
Managed Programs
Master Clear
Memory
Motion Sensor Settings
Regional Settings
Remove Programs
Screen
SIM Lock
Sleep Mode Indicator
Task Manager
Video Quality Setting
Volume Settings
Microsoft My Phone
Getting Started
Pictures & Videos
Windows Media
Marketplace
Microsoft My Phone
MSN Weather
MSN Money
Calculator
Games
 Bubble Breaker
 Solitaire
 NFS Undercover Demo
 Monopoly World Demo
Notes
Tasks
Office Mobile
 Excel Mobile
 OneNote Mobile
 PowerPoint Mobile
 Word Mobile
File Explorer
ActiveSync
Internet Sharing
Task Manager
Search Phone
Help
Adobe Reader LE
Camera

Annex 2 - Navigating your Toshiba phone

Contacts Backup

Java

Orange Maps

PhotoBase

Live Search

SIM Manager

switchUSB

TV Player

Video Player

Video Editor

CorePlayer

Homescreen Selector



















Other Services

Windows Live











Annex 3 - Common status icons

Type	Icon	Description
Radio signal icons		Signal strength
		No signal
		No radio service. The phone has not yet connected to a network.
		Radio signal lost. The phone is searching for a signal.
		Phone set to Off.
		GPRS available
		3G+ available
		EDGE available
		3G/UMTS available
		HSDPA available
		Connecting to GPRS
		Connecting to EDGE
		Connecting to 3G/UMTS
		Connecting to HSDPA
		Active GPRS connection
		Active EDGE connection
		Active 3G/UMTS connection
		Active HSDPA connection
		Roaming

Annex 3 - Common status icons

Type	Icon	Description
Connectivity icons		Bluetooth set to On .
		Incoming beam.
		Wi-Fi set to On .
		Wi-Fi network(s) in range.
		Animated - connecting to a Wi-Fi network. Static - connected to a Wi-Fi network.
Call icons		Call in progress
		Data call in progress
		Call on hold
		Speakerphone on
		Calls forwarded
		Missed call
Volume icons		Ringer on for incoming calls
		Ringer off for incoming calls
		Vibrate for incoming calls
Notification icons		New message(s) received (includes voice mail messages)*
		New voice mail message received*
		New instant message(s) received
		New MMS message(s) received

Annex 3 - Common status icons

Type	Icon	Description
Notification icons		Multiple notifications. This icon is displayed when there are multiple occurrences that would normally each display an icon, for example, when there is a missed call and a message received. This icon is displayed automatically after the last notification icon has been displayed briefly. You can tap this icon to view the individual notifications.
Battery icons		Battery level
		Battery level low
		Battery charging
ActiveSync icons		Synchronisation over GPRS in progress
		Synchronisation over EDGE in progress
		Synchronisation over 3G/UMTS in progress
		Synchronisation over Wi-Fi in progress
		Synchronisation error
Other icons		Alarm pending
		No SIM card

* The type of voice mail message indicator displayed is dependent on your service provider. Your service provider may also allow you to select the type of voice mail notification that you receive. Please contact your service provider for details.

Annex 4 - Configuring SMS, MMS and e-mail

Setting up text messages service centre

To set up the text messages service centre:

1. Access **Easy Connection**.
2. Tap **Mail Settings**.
3. Tap **SMS**.
4. Enter the required number in the **Text messages service centre:** field. This number can be obtained from your service provider.
5. Tap **OK**.



TIP: You can also set up the text messages service centre from the **Phone** settings.

Configuring MMS settings

If your Toshiba phone has not been preconfigured, you will need to manually enter the details of the MMS account. These details are available from your service provider.

To configure MMS settings:

1. Access **Easy Connection**.
2. Tap **Mail Settings**.
3. Tap **MMS**.
4. Tap **Add New**.
5. Enter the following details:
 - **Server name:** - enter a descriptive name, such as the name of your service provider.
 - **Gateway:** - enter the WAP gateway to be used for this connection.
 - **Server address:** - enter the URL address of the MMS server.
6. Tap **Next**.
7. Enter the following details:
 - **Port number:** - enter the HTTP port number for connecting to the MMS server and for file transfer.

Annex 4 - Configuring SMS, MMS and e-mail

- **Message sending size limit:** - select the maximum MMS message size permitted by your service provider.
- **Connect via:** - select the connection point for the MMS server.

8. Tap **OK**.



TIP: If you have several MMS providers, you can set one as the default. To do this, scroll to the required entry, then tap **Default**. A check mark is displayed next to the default MMSC entry.

Setting up e-mail accounts

Setting up an e-mail account automatically

To set up an e-mail account automatically:

1. Tap **Start > E-mail**.
2. Tap **Setup E-mail**.
3. In the **E-mail address:** field, enter the e-mail address for this account.
4. Enter a password in the **Password:** field.



TIP: Choose a strong password - strengthen the security of your password by selecting a combination of alphabet and numeric characters.

5. Tick the **Save password** checkbox if you wish to save your password to your Toshiba phone. This will mean that you do not need to enter it each time you connect to your e-mail server. This may or may not be required by your internet service provider (ISP).

Annex 4 - Configuring SMS, MMS and e-mail

 **WARNING:** If you save your password and then lose your Toshiba phone, you run the risk of someone else being able to access your e-mail account.

6. Tap **Next**.
7. Ensure that the **Try to get e-mail settings automatically from the Internet** is ticked, then tap **Next**.

If the account has set up successfully, you are prompted to send and receive e-mail.

If the account has not set up successfully, tap **Next** and then set up the account manually.

Setting up an Internet or custom domain e-mail account manually

You will need to set up an Internet or custom domain e-mail account if your e-mail provider supports POP or IMAP e-mail. Contact your e-mail provider for further information.

A custom domain e-mail account has an address hosted by a different provider than indicated by the domain. For example, your e-mail address may be “user@mycompany.com”,

although “live.com” hosts the account and provides the messaging services.

 **NOTE:** Before setting up the account, you will need to obtain the required information from your e-mail provider.

To set up an Internet or custom domain e-mail account manually:

1. Tap **Start > E-mail**.
2. Tap **Setup E-mail**.
3. In the **E-mail address:** field, enter the e-mail address for this account.
4. Enter a password in the **Password:** field.
5. Tick the **Save password** checkbox if you wish to save your password to your Toshiba phone. This will mean that you do not need to enter it each time you connect to your e-mail server. This may or may not be required by your internet service provider (ISP).
6. Tap **Next**.
7. Untick the **Try to get e-mail settings automatically from the Internet**

Annex 4 - Configuring SMS, MMS and e-mail

checkbox, then tap **Next**.

8. In the **Your e-mail provider:** field, select **Internet e-mail** or **Custom domain** as required.

9. Tap **Next**.

10. If you are setting up a custom domain e-mail account, enter the domain of your e-mail address provider in the **E-mail provider domain:** field, then tap **Next**.

11. Enter the name that you want displayed when you send e-mail in the **Your name:** field.

12. Enter a unique name for this account in the **Account display name:** field, then tap **Next**.

 **NOTE:** This name cannot be changed later.

13. Enter the name of the incoming server in the **Incoming mail server:** field.

14. Select the server type that hosts your e-mail mailbox in the **Account type:** list (**POP3** or **IMAP4**), then tap **Next**.

15. Enter the user name assigned to you by your ISP in the **User name:** field. This is usually the first part of your e-mail address, before the '@' sign.

16. Tap **Next**.

17. Enter the name of the outgoing server in the **Outgoing (SMTP) mail server:** field.

18. Tick the **Outgoing server requires authentication** checkbox if the outgoing server requires authentication. This authentication will use the user name and password that you have already entered.

19. Tick the **Use the same user name and password for sending e-mail** checkbox if required.

20. Tap the **Advanced Server Settings** link to set the following additional settings if required.

Tick the checkboxes if you wish to enable Secure Sockets Layer (SSL) connection.

Annex 4 - Configuring SMS, MMS and e-mail

 **IMPORTANT:** SSL connection enables you to send and/or receive personal information more securely. If you select one or both of these options and your ISP does not support SSL connection, you will not be able to send and/or receive e-mail.

The **Network connection:** field enables you to select the network to which your e-mail server connects.

Tap **Done** when you have finished.

21. Tap **Next**.

22. Select the frequency with which to send and receive your e-mail in the **Automatic Send/Receive:** field.

23. Tap the **Review all download settings** link to set the following additional settings if required:

The **Download messages:** field enables you to set the time range for downloading messages from the server.

Tap **Advanced Settings** to edit additional settings for sending, receiving and deleting e-mails if required.

Tap **Done**, then **Next** when you have finished.

24. Select the format for sending messages (**HTML** or **Plain Text**) in the **Message format:** field.

25. Select the download size limitation in the **Message download limit:** field.

26. Select the download preferences for attachments in IMAP4 e-mails in the **Download attachments:** field.

27. Tap **Finish**.

Setting up an Outlook e-mail account manually

An Outlook e-mail account is created and managed by a Microsoft Exchange server, usually within a company or other organisation.

 **NOTE:** You need to have an e-mail account set up on the Exchange server before you can receive e-mails from this account on your Toshiba phone. Contact the administrator of the Exchange server for further information.

Annex 4 - Configuring SMS, MMS and e-mail

 **NOTE:** Before setting up the account, you will need to obtain the required information about the Exchange server. Contact the administrator of the Exchange server for further information.

To set up an Outlook e-mail account manually:

1. Tap **Start > E-mail**.
2. Tap **Setup E-mail**.
3. In the **E-mail address:** field, enter the e-mail address for this account.
4. Enter the password of your Outlook e-mail account in the **Password:** field.
5. Tick the **Save password** checkbox if you wish to save your password to your Toshiba phone. This will mean that you do not need to enter it each time you connect to your e-mail server. This may or may not be required by your internet service provider (ISP).
6. Tap **Next**.
7. Untick the **Try to get e-mail settings automatically from the Internet** checkbox, then tap **Next**.
8. In the **Your e-mail provider:** field, select **Exchange server**, then tap **Next**.
9. Tap **Next**.
10. Tap **Next**.
11. Enter the address of the Exchange server in the **Server address:** field.
12. If the Exchange server uses SSL, ensure that the **This server requires an encrypted (SSL) connection** checkbox is ticked.
13. Tap **Next**.
14. Make sure that the user name and password information is correct.
15. Enter the Exchange server domain in the **Domain:** field, then tap **Next**.
16. Select the data that you would like to synchronise with the Exchange server (from **Contacts, Calendar, E-mail, Tasks** and **Text Messages**).
17. Tap **Finish**.
18. Wait for the synchronisation to finish. This may take several minutes.

Annex 4 - Configuring SMS, MMS and e-mail

General messaging options

You can customise the options for your **Messaging** accounts, message options, addressing, and message storage.

To access the **Messaging** options:

1. Tap **Start > E-mail**.
2. Tap **Menu > Options**.
3. Customise the following options as required:
 - **Accounts** tab - enables you to change the settings for each messaging account. Tap **New account...** to set up a new messaging account. Tick the **Display account picker when opening Messaging** checkbox if you would like to select the messaging account each time you open **Messaging**.
 - **Message** tab - enables you to change options for sending and deleting messages.
 - **Address** tab - enables you to select whether to check **Contacts** as well as any online address books for e-mail addresses. You can also add online address books and

select which ones to use for e-mail address checking.

- **Storage** tab - enables you to check the memory space of your phone, storage card and attachments. You can also select whether to store attachments on a storage card, and specify how deleted items are emptied.

Inserting a signature

To create a signature and insert it in messages:

1. Tap **Start > E-mail**.
2. Tap **Menu > Options**.
3. On the **Accounts** tab, tap **Signatures...**
4. In the **Select an account:** field, select the account for which you are creating the signature.
5. Tick the **Use signature with this account** checkbox.
6. To insert a signature in every message you send, tick the **Use when replying and forwarding** checkbox. If this checkbox is not ticked, the signature is inserted in new

Annex 4 - Configuring SMS, MMS and e-mail

messages only.

7. Enter the signature.
8. Tap the **X/OK key** or **OK** twice.

Annex 5 - Configuring internet settings

 **NOTE:** Before you begin, you will need to obtain the following information:

- From your phone service provider - data connectivity plan information, access point name, and PAP/CHAP security settings.
- From your ISP or wireless service provider - access point name, user name and password, and other security information.

Setting up a GPRS connection

GPRS is a packet-based wireless communication service which enables data to be sent and received using mobile phones.

You can use GPRS to connect to the Internet or to send and receive MMS messages using your phone. When you use GPRS, you will usually be billed based on the data traffic volume.

However, you should check billing information with your service provider.

 **NOTE:** Before setting up a GPRS connection, you will need to obtain the required settings from your service provider. As a minimum, the access point name will be required.

To set up a GPRS connection manually:

1. Access **Easy Connection**.
2. Tap **Network Settings**.
3. Tap **Network Settings**.
4. Select **Cellular Line (GPRS)**, then tap **Next**.
5. In the **Access point name:** field, enter the GPRS access point name (APN) for your service provider, then tap **Next**.
6. In the **User name:** field, enter your user name for the network, then tap **Next**.
7. In the **Password:** field, enter your password for the network, then tap **Next**.
8. If you need to specify extra settings, tap one or more of the following items and enter the required information:
 - **Domain** - enter the domain name, then tap **OK**.

Annex 5 - Configuring internet settings

- **IP Address** - select **Use server-assigned IP address** to automatically configure the IP address. Otherwise, select **Use specific IP address** and manually enter the IP address.

Tap **Next**.

Tick the checkbox(es) for the required types of compression, then tap **OK**.

- **Server Address** - to automatically configure the server address, select **Use server-assigned address**, then tap **OK**. Otherwise, select **Use specific server address** to manually enter the server address information in the **Primary DNS:**, **Secondary DNS:**, **Primary WINS:**, and **Secondary WINS:** fields.

Tap **OK**.

9. **Authentication** - select one of the following:
 - **None** - no authentication (default).
 - **CHAP** - use Challenge Handshake Authentication Protocol.
 - **PAP** - use Password Authentication

Protocol.

10. Tap **OK** twice.

11. In the **ISP name:** field, enter a name for the GPRS connection.

12. Tap **OK**.

Setting up a dial-up connection



NOTE: Before setting up a dial-up connection, you will need to obtain the required settings from your service provider.

To set up a dial-up connection:

1. Access **Easy Connection**.
2. Tap **Network Settings**.
3. Tap **Network Settings**.
4. Select **Cellular Line**, then tap **Next**.
5. In the **Dialling number:** field, enter the phone number used to dial the network, then tap **Next**.
6. Enter the required information. See **Setting up a GPRS connection** for details.
7. Tap **OK**.

Annex 5 - Configuring internet settings

Setting up a VPN connection

 **IMPORTANT:** Please ensure that you have set up a GPRS connection before attempting to set up a VPN connection. The VPN connection uses the GPRS connection to connect to a network, such as a corporate network.

 **NOTE:** Before setting up a VPN connection, you will need to obtain the required settings.

To set up a VPN connection:

1. Access **Easy Connection**.
2. Tap **Network Settings**.
3. Tap **Advanced**.
4. On the **Tasks** tab, tap **Add a new VPN server connection** in the **My Work Network** section.
5. Enter the following information:
 - **Name:** - name for the connection.
 - **Host name/ IP:** - name of the VPN server.
 - **VPN type:** - select the type of VPN.
6. Tap **Next**.
7. If you selected **IPSec/L2TP** in the **VPN type:** field, select the type of authentication. Enter the pre-shared key if required. Tap **Next**.
8. Enter the required information. See **Setting up a GPRS connection** for details.
9. Tap **Finish**.

Annex 5 - Configuring internet settings

Setting up a proxy connection

Depending on your service provider's configuration, you may need to add a proxy connection to allow your Toshiba phone to access the Internet or WAP services.

Your service provider will be able to advise whether you need to create a proxy connection.



NOTE: Before setting up a proxy connection, you will need to obtain the required settings from your service provider.

To set up a proxy connection:

1. Access **Easy Connection**.
2. Tap **Network Settings**.
3. Tap **Advanced**.
4. On the **Tasks** tab, tap **Set up my proxy server** for the required group.
5. On the **Proxy Settings** tab, tick the **This network connects to the Internet** and **This network uses a proxy server to connect to the Internet** checkboxes.
6. In the **Proxy server:** field, enter the name of the proxy server.
7. If you need to specify extra settings, tap the **Advanced...** button and edit the settings as required.
Tap the **X/OK key** or **OK** when you have finished.
8. Tap the **X/OK key** or **OK**.

Annex 5 - Configuring internet settings

Connecting to intranet URLs

Some URLs for corporate intranet pages may use '.' characters, for example: intranet.companyname.com. To view these pages, you need to set up a URL exception.

To set up a URL exception:

1. Access **Easy Connection**.
2. Tap **Network Settings**.
3. Tap **Advanced**.
4. Tap the **Advanced** tab.
5. Tap the **Exceptions...** button.
6. Tap **Add new URL....**
7. In the **Work URL:** field, enter the required URL.
8. Tap the **X/OK key** or **OK** three times.

Toshiba Corporation

i IMPORTANT: PLEASE READ THE FOLLOWING BEFORE USING YOUR MOBILE PHONE AS ATTEMPTING TO USE ANY SOFTWARE ON THE SUPPLIED PHONE CONSTITUTES YOUR ACCEPTANCE OF THESE EULA TERMS. IF YOU REJECT OR DO NOT AGREE WITH ALL THE TERMS OF THIS EULA, PLEASE DO NOT ATTEMPT TO ACCESS OR USE THE SUPPLIED SOFTWARE.

End User License Agreement

This End User License Agreement ("EULA") is a legal agreement between you (as the user) and TOSHIBA CORPORATION ("Toshiba") with regard to the copyrighted software installed in a Toshiba 3G mobile phone supplied to you (the "Phone").

Use or employment of any software installed in the Phone and related documentations (the "Software") will constitute your acceptance of these terms, unless separate terms are provided by the Software supplier on the Phone, in which case certain additional or different terms may apply. If you do not agree with the terms of this EULA, do not use or employ the Software.

1. **License Grant.** Toshiba grants to you a personal, non-transferable and non-exclusive right to use the Software as set out in this EULA. Modifying, adapting, translating, renting, copying, making available, transferring or assigning all or part of the Software, or any rights granted hereunder, to any other persons, and removing any proprietary notices, labels or marks from the Software is strictly prohibited, except as expressly permitted in this EULA. Furthermore, you hereby agree not to create derivative works based on the Software.
2. **Copyright.** The Software is licensed, not sold. You acknowledge that no title to the intellectual property in the Software is or will be transferred to you. You further acknowledge that title and full ownership rights to the Software will remain the exclusive property of Toshiba, Toshiba's affiliates, and/or their suppliers, and you will not acquire any rights to the Software, except as expressly set out in this EULA. You may keep a backup copy of the Software only so far as necessary for its lawful use. All copies

of the Software must contain the same proprietary notices as contained in the Software and are subject to the terms of this EULA. All rights not expressly granted under this EULA are reserved to Toshiba, Toshiba's affiliates and/or their suppliers.

3. **Reverse Engineering.** You agree that you will not attempt, and if you are a business organisation, you will use your best efforts to prevent your employees, workers and contractors from attempting, to reverse engineer, decompile, modify, translate or disassemble the Software in whole or in part except to the extent that such actions cannot be excluded by mandatory applicable law and only if those actions are taken in accordance with such applicable law. Any failure to comply with the above or any other terms and conditions contained herein will result in the automatic termination of this license and the reversion of the rights granted hereunder to Toshiba.
4. **LIMITED WARRANTY.** Only during the warranty period for the Phone, Toshiba, Toshiba's affiliates, its suppliers or its authorised service company will repair or replace, at Toshiba's sole discretion, defective Software unless such defect results from acts or incidences beyond the reasonable control of Toshiba. EXCEPT AS PROVIDED IN THIS EULA: (A) TOSHIBA, TOSHIBA'S AFFILIATES, AND THEIR SUPPLIERS DISCLAIM ALL WARRANTIES, CONDITIONS OR OTHER TERMS (WHETHER EXPRESS OR IMPLIED), INCLUDING BUT NOT LIMITED TO WARRANTIES, CONDITIONS AND TERMS OF SATISFACTORY QUALITY, MERCHANTABILITY, FITNESS FOR A PARTICULAR PURPOSE AND NON-INFRINGEMENT OF THIRD-PARTY RIGHTS; AND (B) THE ENTIRE RISK AS TO THE QUALITY AND PERFORMANCE OF THE SOFTWARE IS WITH YOU. YOU ACCEPT THAT THE SOFTWARE MAY NOT MEET YOUR REQUIREMENTS AND NO WARRANTY CAN BE GIVEN THAT OPERATION OF THE SOFTWARE WILL BE UNINTERRUPTED OR ERROR-FREE.

Toshiba Corporation

5. **LIMITATION OF LIABILITY.** TO THE FULLEST EXTENT LEGALLY PERMITTED, IN NO EVENT SHALL TOSHIBA, TOSHIBA'S AFFILIATES OR THEIR SUPPLIERS BE LIABLE TO YOU FOR ANY DAMAGES FOR (A) LOST BUSINESS OR REVENUE, BUSINESS INTERRUPTION, LOSS OF BUSINESS DATA; OR (B) CONSEQUENTIAL, SPECIAL, INCIDENTAL OR INDIRECT DAMAGES OF ANY KIND (WHETHER UNDER CONTRACT, TORT OR OTHERWISE) ARISING OUT OF: (I) THE USE OR INABILITY TO USE THE SOFTWARE, EVEN IF TOSHIBA, TOSHIBA'S AFFILIATES OR THEIR SUPPLIER HAS BEEN ADVISED OF THE POSSIBILITY OF SUCH DAMAGES; OR (II) ANY CLAIM BY A THIRD PARTY. SAVE AS SET OUT IN THIS SECTION, TOSHIBA'S ENTIRE LIABILITY UNDER THIS EULA SHALL NOT EXCEED THE PRICE PAID FOR THE SOFTWARE, IF ANY. THE ABOVE DISCLAIMER AND LIMITATION DOES NOT EXCLUDE OR LIMIT (A) LIABILITY FOR DEATH OR PERSONAL INJURY CAUSED BY NEGLIGENCE; OR (B) ANY MANDATORY LEGAL RIGHT OR LIABILITY TO THE EXTENT THAT IT CANNOT BE LAWFULLY EXCLUDED OR LIMITED UNDER APPLICABLE LAW. PLEASE MAKE AND RETAIN A COPY OF ALL DATA YOU HAVE INSERTED INTO YOUR PRODUCT, FOR EXAMPLE NAMES, ADDRESSES, PHONE NUMBERS, PICTURES, RINGTONES ETC., BEFORE SUBMITTING YOUR PRODUCT FOR A WARRANTY SERVICE, AS SUCH DATA MAY BE DELETED OR ERASED AS PART OF THE REPAIR OR SERVICE PROCESS.
6. **Laws.** This EULA will be governed by the laws of England and Wales. All disputes arising out of this EULA shall be subject to the exclusive jurisdiction of the English Courts.
7. **Export Laws.** Any use, duplication or employment of the Software involves products and/or technical data that may be controlled under the export laws of applicable countries or region, and may be subject to the approval of the applicable governmental authorities prior to export. Any export, directly or indirectly, in contravention of the export laws of applicable

countries or region is prohibited.

8. **Third Party Beneficiary.** You agree that certain suppliers of the Software to Toshiba have a right as a third party beneficiary to enforce the terms of this EULA against you as a user.
9. **Transfers.** The Software may be transferred only as installed on the Phone to a lawful third party user, where that party accepts the terms of this EULA, which will continue to apply.
10. IF YOU ARE DEALING AS A CONSUMER IN THE UK AND THE SOFTWARE QUALIFIES AS 'GOODS', YOUR STATUTORY RIGHTS UNDER APPLICABLE LAW ARE NOT AFFECTED.
11. The Software is subject to change for upgrading purposes without prior notice.

EU Warranty

Your Toshiba phone, battery and AC charger contain no user serviceable parts. For further information on service, please contact your retailer or service provider.

End User License Agreements (EULAs)

MICROSOFT SOFTWARE LICENSE TERMS FOR WINDOWS MOBILE 6.5 SOFTWARE

These license terms are an agreement between you and TOSHIBA. Please read them. They apply to the software included on this device. The software also includes any separate media on which you received the software.

The software on this device includes software licensed by TOSHIBA from Microsoft Corporation or its affiliate.

The terms also apply to any

- updates,
- supplements,
- Internet-based services, and
- support services

for this software, unless other terms accompany those items. If so, those terms apply.

As described below, using some features also operates as your consent to the transmission of certain standard computer information for Internet-based services.

By using the software, including use on this device, you accept these terms. If you do not accept them, do not use the device or software. Instead, contact TOSHIBA to determine its return policy for a refund or credit.

WARNING: If the software contains voice operated technologies, then operating this software requires user attention. Diverting attention away from the road while driving can possibly cause an accident or other serious consequence. Even occasional, short diversions of attention can be dangerous if your attention is diverted away from your driving task at a critical time. TOSHIBA and Microsoft make no representations, warranties or other determinations that ANY use of this software is legal, safe, or in any manner recommended or intended while driving or otherwise operating a motor vehicle.

If you comply with these license terms, you have the rights below.

1. **USE RIGHTS.** You may use the software on the device with which you acquired the software.
2. **ADDITIONAL LICENSING REQUIREMENTS AND/OR USE RIGHTS.**
 - a. **Specific Use.** TOSHIBA designed this device for a specific use. You may only use the software for that use.
 - b. **Included Microsoft Programs and Additional Required Licenses.** Except as provided below, these license terms apply to all Microsoft programs included with the software. If the license terms with any of those programs give you other rights that do not expressly conflict with these license terms, you also have those rights.
 - i. This agreement does not grant you any rights with respect to the Windows Mobile Device Center, Microsoft ActiveSync or Microsoft Outlook 2007 Trial which are subject to the licenses accompanying those items.
 - c. **Speech Recognition.** If the software includes speech recognition component(s), you understand that speech recognition is an inherently statistical process and that recognition errors are inherent in the process. Neither TOSHIBA nor Microsoft or their suppliers shall be liable for any damages arising out of errors in the speech recognition process.
 - d. **Phone Functionality.** If the device software includes phone functionality, all or certain portions of the device software may be inoperable if you do not have and maintain a service account with a wireless telecommunication carrier ("Mobile Operator"), or if the Mobile Operator's network is not operating or configured to operate with the device.
3. **SCOPE OF LICENSE.** The software is licensed, not sold. This agreement only gives you some rights to use the software. TOSHIBA and Microsoft reserve all other rights. Unless applicable law gives you more rights despite this limitation, you

End User License Agreements (EULAs)

may use the software only as expressly permitted in this agreement. In doing so, you must comply with any technical limitations in the software that allow you to use it only in certain ways. You shall not:

- work around any technical limitations in the software;
- reverse engineer, decompile or disassemble the software;
- make more copies of the software than specified in this agreement;
- publish the software for others to copy;
- rent, lease or lend the software; or
- use the software for commercial software hosting services.

Except as expressly provided in this agreement, rights to access the software on this device do not give you any right to implement Microsoft patents or other Microsoft intellectual property in software or devices that access this device.

You may use remote access technologies in the software such as Remote Desktop Mobile to access the software remotely from a computer or server. You are responsible for obtaining any licenses required for use of the protocols to access other software.

4. **INTERNET-BASED SERVICES.** Microsoft provides Internet-based services with the software. Microsoft may change or cancel them at any time.
 - a. **Consent for Internet-based Services.** The software features described below connect to Microsoft or service provider computer systems over the Internet. In some cases, you will not receive a separate notice when they connect. You may switch off some of these features or not use them. For more information about these features, visit <http://go.microsoft.com/fwlink/?LinkId=81931>. **By using these features, you consent to the transmission of this information.** Microsoft does not use the information to identify or contact you. **Device Information.** The following features use Internet protocols, which send to the appropriate systems device information, such as your Internet protocol address, the type

of operating system, browser and name and version of the software you are using, and the language code of the device where you installed the software. Microsoft uses this information to make the Internet-based services available to you.

- **Windows Mobile Update Feature.** The Windows Mobile Update feature provides you the ability to obtain and install software updates on your device if updates are available. You may choose not to use this feature. TOSHIBA and/or your Mobile Operator may not support this feature or an update for your device.
 - **Windows Media Digital Rights Management.** Content owners use Windows Media digital rights management technology (WMDRM) to protect their intellectual property, including copyrights. This software and third party software use WMDRM to play and copy WMDRM-protected content. If the software fails to protect the content, content owners may ask Microsoft to revoke the software's ability to use WMDRM to play or copy protected content. Revocation does not affect other content. When you download licenses for protected content, you agree that Microsoft may include a revocation list with the licenses. Content owners may require you to upgrade WMDRM to access their content. Microsoft software that includes WMDRM will ask for your consent prior to the upgrade. If you decline an upgrade, you will not be able to access content that requires the upgrade.
 - b. **Misuse of Internet-based Services.** You shall not use these services in any way that could harm them or impair anyone else's use of them. You shall not use the services to try to gain unauthorized access to any service, data, account or network by any means.
5. **NOTICES ABOUT THE MPEG-4 VISUAL STANDARD.** The software may include MPEG-4 visual decoding technology. This technology is a format for data compression of video information. MPEG LA, L.L.C. requires this notice:
USE OF THIS PRODUCT IN ANY MANNER THAT COMPLIES

End User License Agreements (EULAs)

WITH THE MPEG 4 VISUAL STANDARD IS PROHIBITED, EXCEPT FOR USE DIRECTLY RELATED TO (A) DATA OR INFORMATION (i) GENERATED BY AND OBTAINED WITHOUT CHARGE FROM A CONSUMER NOT THEREBY ENGAGED IN A BUSINESS ENTERPRISE, AND (ii) FOR PERSONAL USE ONLY; AND (B) OTHER USES SPECIFICALLY AND SEPARATELY LICENSED BY MPEG LA, L.L.C.

If you have questions about the MPEG-4 visual standard, please contact MPEG LA, L.L.C., 250 Steele Street, Suite 300, Denver, CO 80206; www.mpegla.com.

- DIGITAL CERTIFICATES.** The software uses digital certificates in X.509 format. These digital certificates are used for authentication.
- CONNECTIVITY SOFTWARE.** Your device package may include Windows Mobile Device Center or Microsoft ActiveSync software. If it is included, then you may install and use it in accordance with the license terms that are provided with it. If no license terms are provided, then you may install and use only one (1) copy of the software on a single computer.
- NETWORK ACCESS.** If you are using a network, such as an employer network, the network administrator may limit features or functionality on your device.
- PRODUCT SUPPORT.** Contact TOSHIBA for support options. Refer to the support information provided with the device.
- LINKS TO THIRD PARTY WEBSITES.** If the software provides links to third party websites, those links are provided to you only as a convenience, and the inclusion of any link does not imply an endorsement of the third party website by Microsoft.
- BACKUP COPY.** You may make one backup copy of the software. You may use it only to reinstall the software on the device.
- PROOF OF LICENSE.** If you acquired the software on the device, or on a disc or other media, a genuine Certificate of Authenticity label with a genuine copy of the software identifies licensed software. To be valid, this label must be affixed to the device, or included on or in TOSHIBA's software packaging. If you receive the label separately, it is not valid. You should keep the label on the device or packaging to prove that you are licensed to use the software. To identify genuine Microsoft software, see <http://www.howtotell.com>.
- TRANSFER TO A THIRD PARTY.** You may transfer the software only with the device, the Certificate of Authenticity label, and these license terms directly to a third party. Before the transfer, that party must agree that these license terms apply to the transfer and use of the software. You may not retain any copies of the software including the backup copy.
- NOT FAULT TOLERANT.** The software is not fault tolerant. TOSHIBA installed the software on the device and is responsible for how it operates on the device.
- RESTRICTED USE.** The Microsoft software was designed for systems that do not require fail-safe performance. You may not use the Microsoft software in any device or system in which a malfunction of the software would result in foreseeable risk of injury or death to any person. This includes operation of nuclear facilities, aircraft navigation or communication systems and air traffic control.
- NO WARRANTIES FOR THE SOFTWARE.** The software is provided "as is". You bear all risks of using it. Microsoft gives no express warranties, guarantees or conditions. Any warranties you receive regarding the device or the software do not originate from, and are not binding on, Microsoft or its affiliates. When allowed by your local laws, TOSHIBA and Microsoft exclude implied warranties of merchantability, fitness for a particular purpose and non-infringement.
- LIABILITY LIMITATIONS.** You can recover from Microsoft and its affiliates only direct damages up to fifty U.S. Dollars (U.S. \$50.00), or equivalent in local currency. You cannot recover any other damages, including consequential, lost profits, special, indirect or incidental damages.

End User License Agreements (EULAs)

This limitation applies to:

- anything related to the software, services, content (including code) on third party internet sites, or third party programs, and
- claims for breach of contract, breach of warranty, guarantee or condition, strict liability, negligence, or other tort to the extent permitted by applicable law.

It also applies even if Microsoft should have been aware of the possibility of the damages. The above limitation may not apply to you because your country may not allow the exclusion or limitation of incidental, consequential or other damages.

18. **EXPORT RESTRICTIONS.** The software is subject to United States export laws and regulations. You must comply with all domestic and international export laws and regulations that apply to the software. These laws include restrictions on destinations, end users and end use. For additional information, see www.microsoft.com/exporting.

End User License Agreement for ArcSoft Software

The following is a legal software license agreement between you, the software end user, and ArcSoft, Inc. Carefully read this license agreement before using the relevant ArcSoft software ("**Software**"). Installing the Software on a computer or other hardware device indicates that you have read this license agreement and agree to its terms.

1. **Grant of License.** This license permits you to use one copy of the Software included in this package or product on any single computer. For each software licensee, the program can be "in use" on only one computer or hardware device at any given time. The Software is "in use" when it is either loaded into RAM or installed into the hard disk or other permanent memory of a computer or other hardware device. A special license permit from ArcSoft is required if the program is going to be installed on a network server for the sole purpose of distribution to other computers. You may not modify, translate, reverse assemble, decompile, disassemble or otherwise attempt (i) to defeat, avoid, bypass, remove, deactivate or otherwise circumvent any software protection mechanisms in the Software, including without limitation any such mechanism used to restrict or control the functionality of the Software, or (ii) to derive the source code or the underlying ideas, algorithms, structure or organization from the Software (except to the extent that such activities may not be prohibited under applicable law).
2. **Copyright.** The Software contained in this package or device is protected by United States copyright laws, international treaty provisions, and all other applicable national laws. The Software must be treated like all other copyrighted materials (e.g. books and musical recordings). This license does not allow the Software to be rented or leased, and the written materials accompanying the Software (if any) may not be copied.

End User License Agreements (EULAs)

3. **Ownership.** Title, ownership rights, and all intellectual property rights in and to the Software and any accompanying documentation, and any copy of the foregoing, shall remain the sole and exclusive property of ArcSoft and/or its third party licensors. You agree to abide by the copyright law and all other applicable laws. You acknowledge that the Software contains valuable confidential information and trade secrets of ArcSoft and/or its third party licensors.
4. **Warranty Disclaimer.** NO WARRANTIES, EITHER EXPRESS OR IMPLIED, ARE MADE WITH RESPECT TO THIS SOFTWARE, INCLUDING BUT NOT LIMITED TO THE IMPLIED WARRANTIES OF MERCHANTABILITY AND FITNESS FOR A PARTICULAR PURPOSE AND WARRANTIES FOR NON-INFRINGEMENT OF INTELLECTUAL PROPERTY, AND ARCSOFT EXPRESSLY DISCLAIMS ALL WARRANTIES NOT STATED HEREIN. YOU ASSUME THE ENTIRE RISK AS TO THE QUALITY AND PERFORMANCE OF THE SOFTWARE. SHOULD THE SOFTWARE PROVE DEFECTIVE, YOU, AND NOT ARCSOFT OR AN AUTHORIZED RESELLER, ASSUME THE ENTIRE COST OF NECESSARY SERVICING, REPAIR, OR CORRECTION. SOME STATES DO NOT ALLOW THE EXCLUSION OF IMPLIED WARRANTIES, SO THE ABOVE EXCLUSION MAY NOT APPLY TO YOU. THIS WARRANTY GIVES YOU SPECIFIC LEGAL RIGHTS, AND YOU MAY ALSO HAVE OTHER RIGHTS THAT VARY FROM STATE TO STATE. YOUR SOLE REMEDY AND THE ENTIRE LIABILITY OF ARCSOFT ARE SET FORTH ABOVE. IN NO EVENT WILL ARCSOFT BE LIABLE TO YOU OR ANY OTHER PERSON FOR ANY DAMAGES, INCLUDING ANY INCIDENTAL OR CONSEQUENTIAL DAMAGES, EXPENSES, LOST PROFITS, LOST SAVINGS, OR OTHER DAMAGES ARISING OUT OF USE OF OR INABILITY TO USE SUCH SOFTWARE.
5. **No Liability for Consequential Damages.** In no event shall ArcSoft be liable for any damages whatsoever (including but not limited to damages for loss of business profits, business interruption, loss of business information, or any other pecuniary

loss) which results from an inability to use this Software, even if ArcSoft, Inc. has been advised of the possibility of such damages. Because some states/jurisdictions do not allow the exclusion or limitation of consequential or incidental damages, the above limitations may not apply to you.

6. **Export.** Subject to permission of the appropriate United States or foreign licenses, export or re-export the product incorporating the Software is able to be made.
7. **U.S. Government Restricted Rights.** If you are a unit or agency of the United States government, the Software and related documentation are deemed to be "commercial computer software" and "commercial computer software documentation," respectively, pursuant to DFAR Section 227.7202 and FAR Section 12.212(b), as applicable. Any use, modification, reproduction, release, performing, displaying or disclosing of the Software and/or the related documentation by the United States government shall be governed solely by the terms of this Agreement and shall be prohibited except to the extent expressly permitted by the terms of this Agreement. Any technical data provided that is not covered by the above provisions is deemed to be "technical data commercial items" pursuant to DFAR Section 227.7015(a). Any use, modification, reproduction, release, performing, displaying or disclosing of such technical data shall be governed by the terms of DFAR Section 227.7015(b).
8. **High Risk Activities.** The Software is not fault-tolerant and is not designed or intended for use in hazardous environments requiring fail-safe performance, or any other application in which the failure of the Software could lead directly to death, personal injury, or severe physical or property damage (collectively, "High Risk Activities"). ARCSOFT EXPRESSLY DISCLAIMS ANY EXPRESS OR IMPLIED WARRANTY OF FITNESS FOR HIGH RISK ACTIVITIES.

End User License Agreements (EULAs)

9. **Termination.** Your rights with respect to the Software may be terminated, either immediately or after a notice period not exceeding thirty (30) days, upon unauthorized copying of the Software or failure to comply with the restrictions contained in this license agreement. Upon termination of the license, you shall **cease to use thereof**.
10. **Governing Law.** If this product was purchased in the United States, this Agreement is governed by the laws of the state of California; otherwise, local laws may apply.

Licenses

Snapdragon™ is a trademark of Qualcomm Incorporated.



Microsoft, Windows, Windows Mobile, Windows Live, Hotmail, Windows Media, ActiveSync, Internet Explorer, Outlook, Excel, PowerPoint and Word are either registered trademarks or trademarks of Microsoft Corporation in the United States and/or other countries.

ArcSoft and the ArcSoft logo are registered trademarks of ArcSoft, Inc.



The Bluetooth™ word mark and logos are trademarks owned by Bluetooth SIG, Inc.



CorePlayer® is a registered trademark of CoreCodec, Inc.



Java™ and all Java-based marks are trademarks or registered trademarks of Sun Microsystems, Inc.



Licenses

microSD™ and the microSD™ logo are trademarks.



The Wi-Fi CERTIFIED Logo is a certification mark of the Wi-Fi Alliance.



Index

A

About 93
AC charger 107
AC charger safety 11
Alarm 95
Attachments 56, 57
Authentication 135

B

Backlight 94, 107
Battery 20, 30, 32, 94, 100, 107
Battery safety 10
Beam 79
Block Recognizer 111
Bluetooth 76
Bluetooth headset 78
Bluetooth mode 76
Browser Settings 95

C

Calendar 59
Call Barring 87, 108
Call barring password 87
Call Forwarding 88, 108
Call History 49
Call Timers 49
Call Waiting 89
Caller ID 88
Camera 66
Certificates 95
Clock 95
Conference calls 48
Contacts 44, 61
Cookies 65
CorePlayer 68
Creating a contact 61
Creating an e-mail 55
Creating an MMS message 53
Custom domain e-mail 128

Index

Customer Feedback 96

D

Date 95

Device lock 83

Device name 93

Dial-up connection 135

Disposal 16

Domain Enroll 80

Drafts 51, 56

Drawing 115

E

Electronic devices 9

E-mail 55

Emergency calls 11

Encryption 96

Ending a call 43

Ending applications 103

Error Reporting 97

European RF Exposure

Information 15

Excel Mobile 58

Exchange server 55, 130

External GPS 97

F

FCC notice 12

File Explorer 68

Fixed Dialing 89

Flight Mode 76

Forwarding a message 51

G

Games 65

Gestures 114

Getting Started 68

GPRS connection 134

GSM 91

Index

H

Hands-free 47
Holding a call 47
HSDPA 91

I

Input Options 115
Input Panel 111
Internal GPS 98
International calls 45
Internet 109
Internet connections 80
Internet e-mail 55, 128
Internet Explorer 64
Internet Favorites 64
Internet History 65
Internet Sharing 80
Internet Zoom 64

J

Java 68

K

Keyboard 112
Keypad tones 87

L

Letter Recognizer 112
Location Request 82

M

Making a call 44
Managed Programs 98
Marketplace 69
Master Clear 99
Memory 100
microSD card 28
Microsoft My Phone 69
MMS messages 52, 109
MMS settings 126

Index

Motion Sensor 38, 94, 100
Muting a call 46

N

Network mode 91
Notes 70

O

Office Mobile 58
OneNote Mobile 58
Operating environment 8
Operator Name 103
Operator Settings 40
Outlook e-mail 130
Owner Information 86

P

Pairing 77
Phone layout 24
Phone lock 84
Phone screen 117

PhotoBase 70
Photos 66
Pictures 71
Pictures & Videos 71
Power 100, 107
PowerPoint Mobile 58
Preferred networks 91
Proxy connection 137

R

Receiving a call 43
Receiving MMS messages 52
Regional Settings 101
Reinitialising 22
Reminders 60
Removing Programs 101
Replying to a message 50
Resetting 22
Restarting 21
Ring tones 87

Index

S

- Screen 102
- Search Phone 71
- Security 83
- Sending a text message 51
- Sending and receiving e-mail 57
- Sending contacts 63
- Setting up e-mail 127
- Signatures 132
- SIM card 27, 28, 108
- SIM Lock 86
- SIM Toolkit 72
- Sleep Mode Indicator 103
- Speakerphone 46
- Speed Dial 45
- Starting and stopping synchronisation 41
- Status icons 123
- Storage card 67

T

- Task Manager 103
- Tasks 72
- Temporary internet files 65
- Text messages 50, 109
- Text messages service centre 126
- Time 95
- Toshiba Free Pad 38, 98
- Toshiba Home Screen 34
- Toshiba Keyboard 112
- Toshiba Menu 36, 86, 118
- Toshiba Touch user interface 34
- Transcriber 113
- Transcriber toolbar 113

U

- USB to PC 81

Index

v

Video Editor 73

Video Quality 103

Videos 67, 71

Voice mail 89

Volume 46

Volume control 82

VPN connection 136

w

Wi-Fi 81

Wi-Fi security 81

Windows Live 73

Windows Media Player 74

Wireless Manager 76

Word Completion 115

Word Mobile 58

©2009 Toshiba Corporation. Toshiba and the Toshiba logo are trademarks of Toshiba Corporation in Japan and other countries.

Other trademarks and trade names may be used here to refer to the product. Toshiba disclaims proprietary interest in the marks and names of others.

TG01-EN-ORG-V2

Available programs, features, and functionality vary by: device, version of Windows Mobile software, mobile network provider, and availability of supporting technology (such as Exchange Server). See www.windowsmobile.com and your device reseller or mobile network provider for more information.