

SAMSUNG

GSM TELEPHONE

SGH-E770

SERVICE *Manual*

GSM TELEPHONE



CONTENTS

1. Specification
2. Flow Chart of Troubleshooting
3. Exploded View and Parts List
4. MAIN Electrical Parts List
5. PCB Diagrams
6. Block Diagrams

1. SGH-E770 Specification

1-1. GSM General Specification

		GSM 900	DCS1800	PCS1900
Freq. Band[MHz] Uplink/Downlink		880~915 925~960	1710~1785 1805~1880	1850~1910 1930~1990
ARFCN range		0~124 & 975~1023	512~885	512~810
Tx/Rx spacing		45MHz	95MHz	80MHz
Mod. Bit rate/ Bit Period	GPRS	270.833Kbps 3.692us	270.833Kbps 3.692us	270.833Kbps 3.692us
	EDGE	812.5Kbps 3.692us	812.5Kbps 3.692us	812.5Kbps 3.692us
Time Slot Period/Frame Period		576.9us 4.615ms	576.9us 4.615ms	576.9us 4.615ms
Modulation	GPRS	0.3GMSK	0.3GMSK	0.3GMSK
	EDGE	8PSK	8PSK	8PSK
MS Power	GPRS	33dBm~5dBm	30dBm~0dBm	30dBm~0dBm
	EDGE	27~5dBm	26~0dBm	26~0dBm
Power Level	GPRS	5pcl~19pcl	0pcl~15pcl	0pcl~15pcl
	EDGE	8~19(class E2)	2~15(class E2)	2~15(class E2)
Sensitivity		-102dBm	-100dBm	-102dBm
TDMA Mux		8	8	8
Cell Radius		35Km	2Km	2Km

1-2. GMSK TX power Level

TX Power control level	GSM900	TX Power control level	DCS1800	TX Power control level	PCS1900
5	33±2dBm	0	30±2dBm	0	30±2dBm
6	31±3dBm	1	28±3dBm	1	28±3dBm
7	29±3dBm	2	26±3dBm	2	26±3dBm
8	27±3dBm	3	24±3dBm	3	24±3dBm
9	25±3dBm	4	22±3dBm	4	22±3dBm
10	23±3dBm	5	20±3dBm	5	20±3dBm
11	21±3dBm	6	18±3dBm	6	18±3dBm
12	19±3dBm	7	16±3dBm	7	16±3dBm
13	17±3dBm	8	14±3dBm	8	14±3dBm
14	15±3dBm	9	12±4dBm	9	12±4dBm
15	13±3dBm	10	10±4dBm	10	10±4dBm
16	11±5dBm	11	8±4dBm	11	8±4dBm
17	9±5dBm	12	6±4dBm	12	6±4dBm
18	7±5dBm	13	4±4dBm	13	4±4dBm
19	5±5dBm	14	2±5dBm	14	2±5dBm
		15	0±5dBm	15	0±5dBm

1-3. EDGE TX Power Level

TX Power control level	GSM850	TX Power control level	DCS1800	TX Power control level	PCS1900
8	27±3dBm	2	26±3dBm	2	26±3dBm
9	25±3dBm	3	24±3dBm	3	24±3dBm
10	23±3dBm	4	22±3dBm	4	22±3dBm
11	21±3dBm	5	20±3dBm	5	20±3dBm
12	19±3dBm	6	18±3dBm	6	18±3dBm
13	17±3dBm	7	16±3dBm	7	16±3dBm
14	15±3dBm	8	14±3dBm	8	14±3dBm
15	13±3dBm	9	12±4dBm	9	12±4dBm
16	11±5dBm	10	10±4dBm	10	10±4dBm
17	9±5dBm	11	8±4dBm	11	8±4dBm
18	7±5dBm	12	6±4dBm	12	6±4dBm
19	5±5dBm	13	4±4dBm	13	4±4dBm
		14	2±5dBm	14	2±5dBm
		15	0±5dBm	15	0±5dBm

2. SGH-E770 Flow Chart of Troubleshooting

2-1.Baseband

2-1-1. Power ON

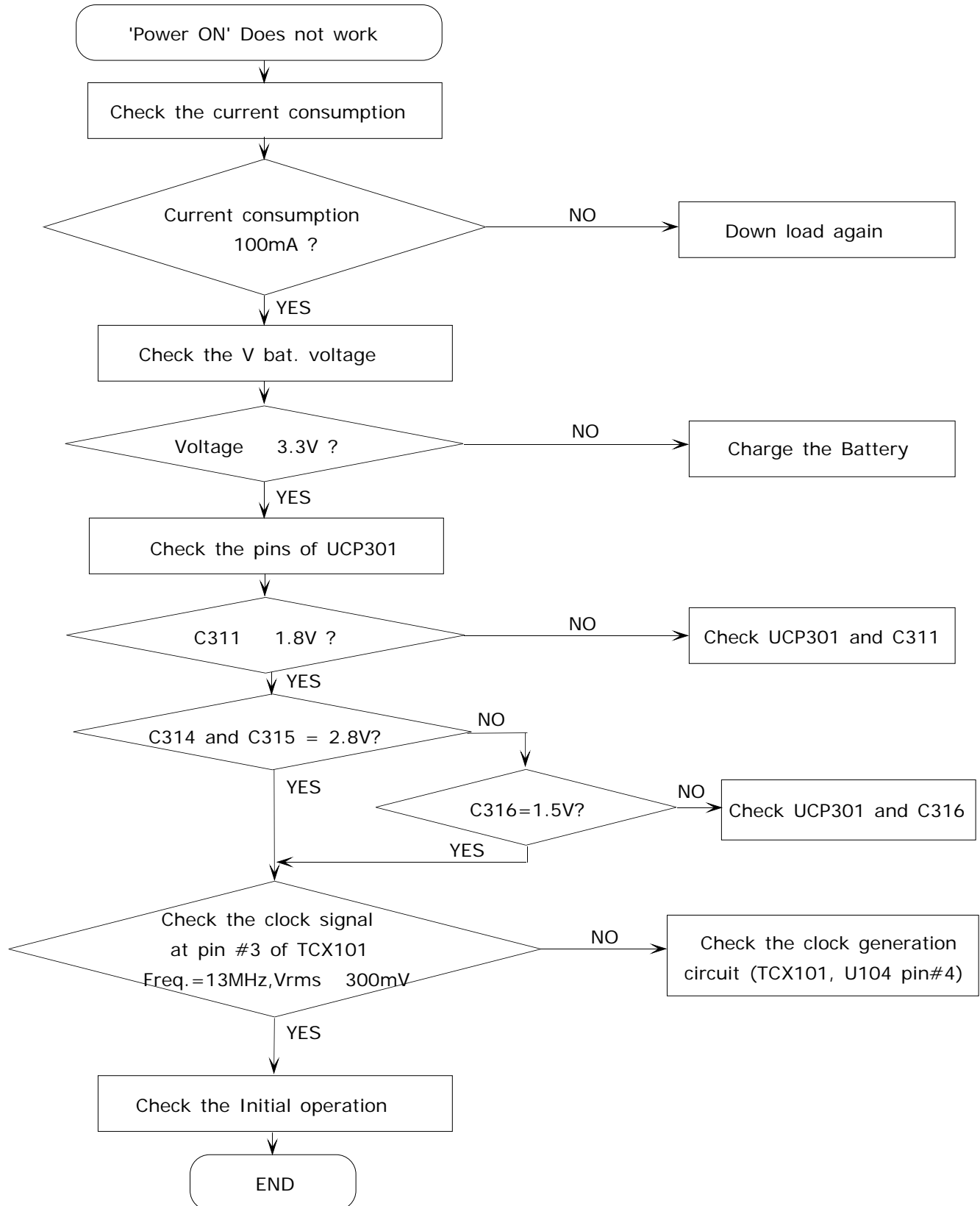

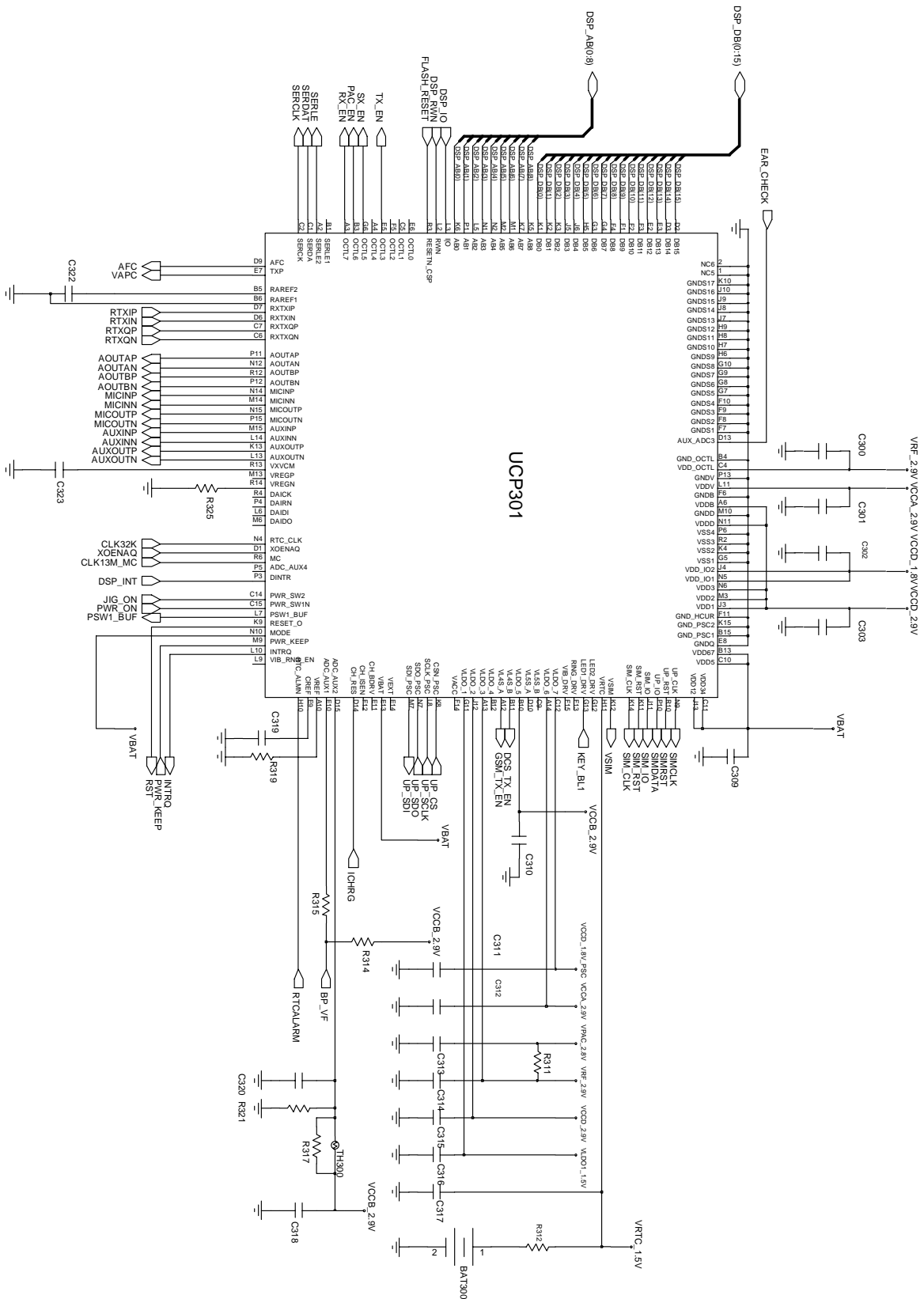

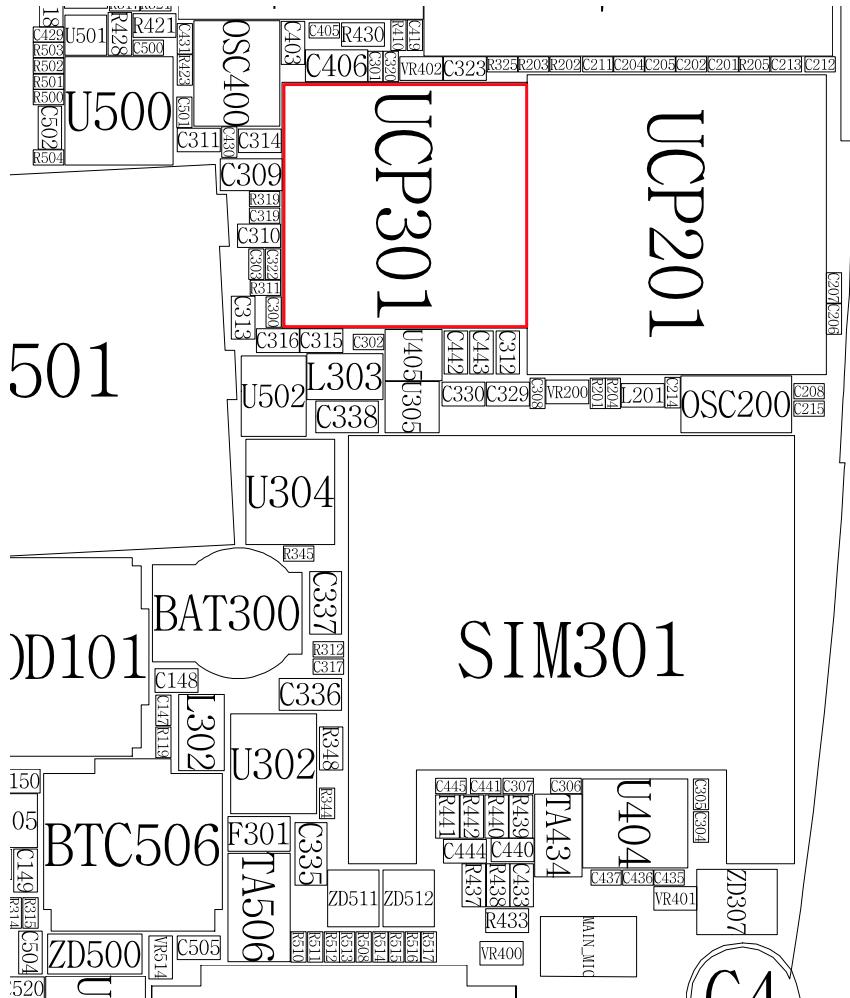

2-1-2. Initial

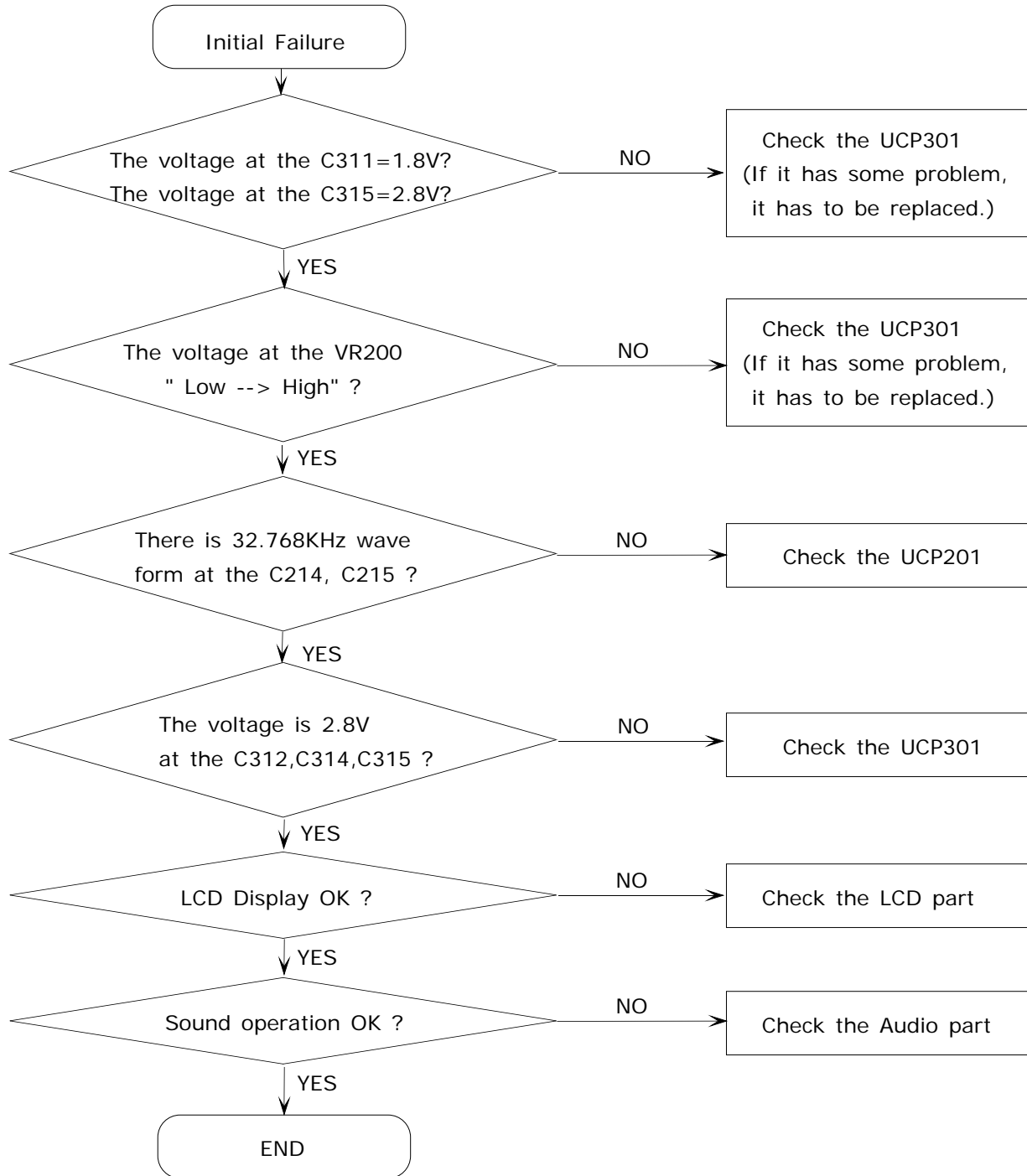

SGH-E770 Flow Chart of Troubleshooting

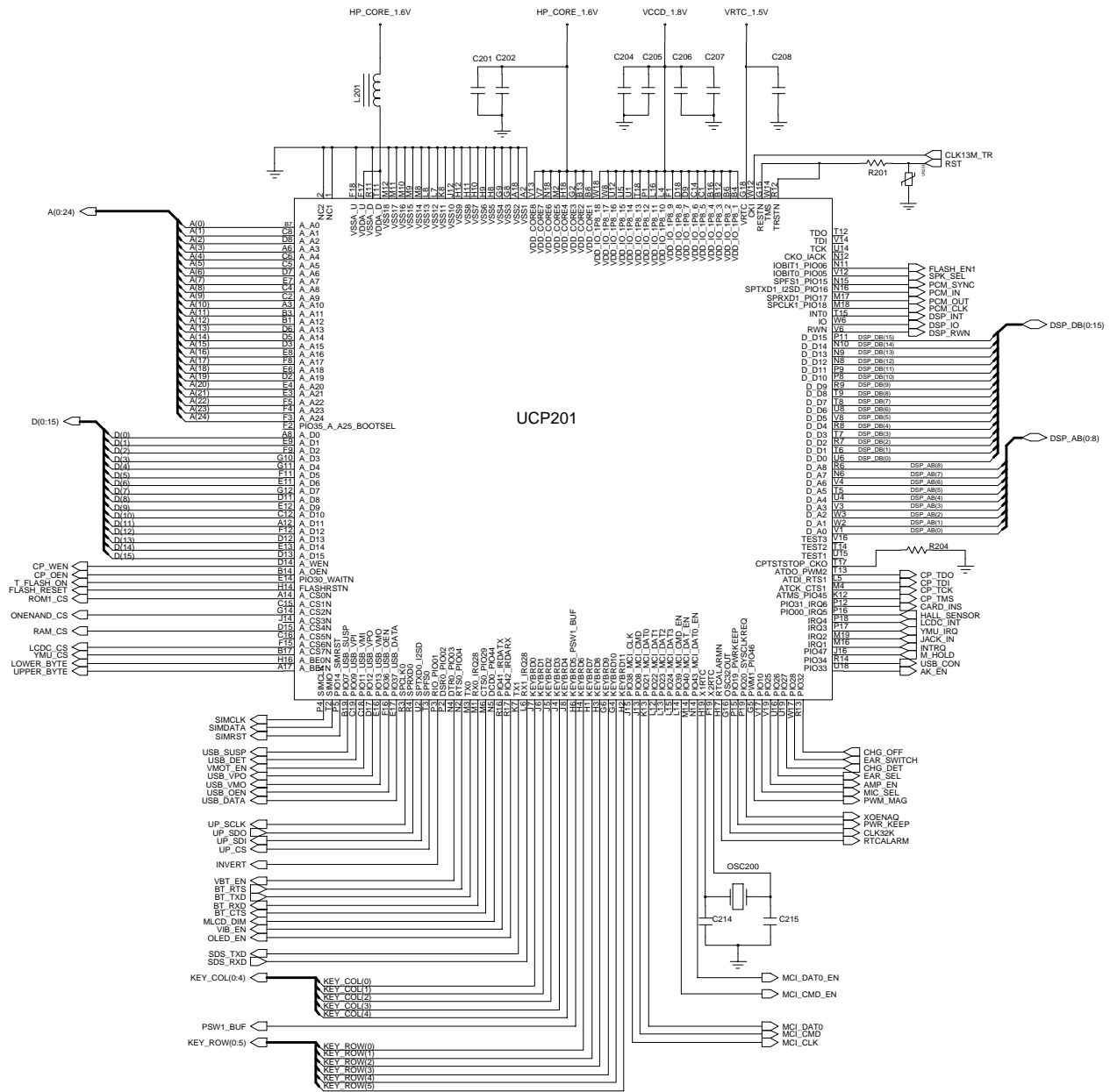

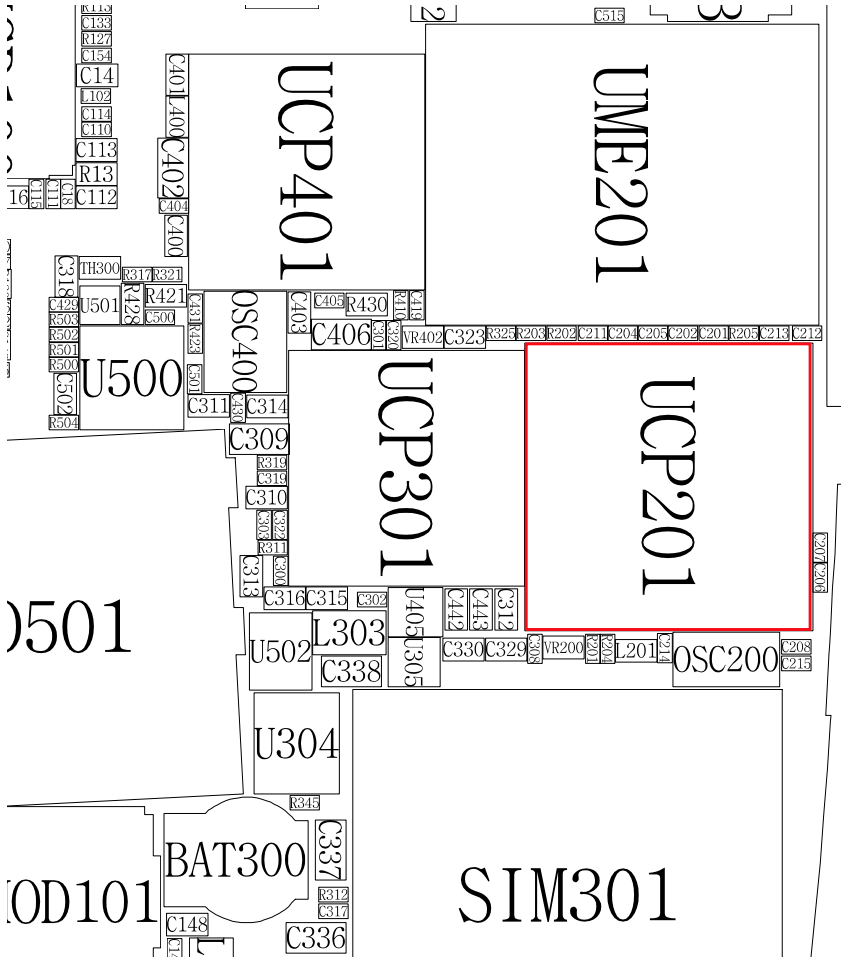

2-1-3. Sim Part

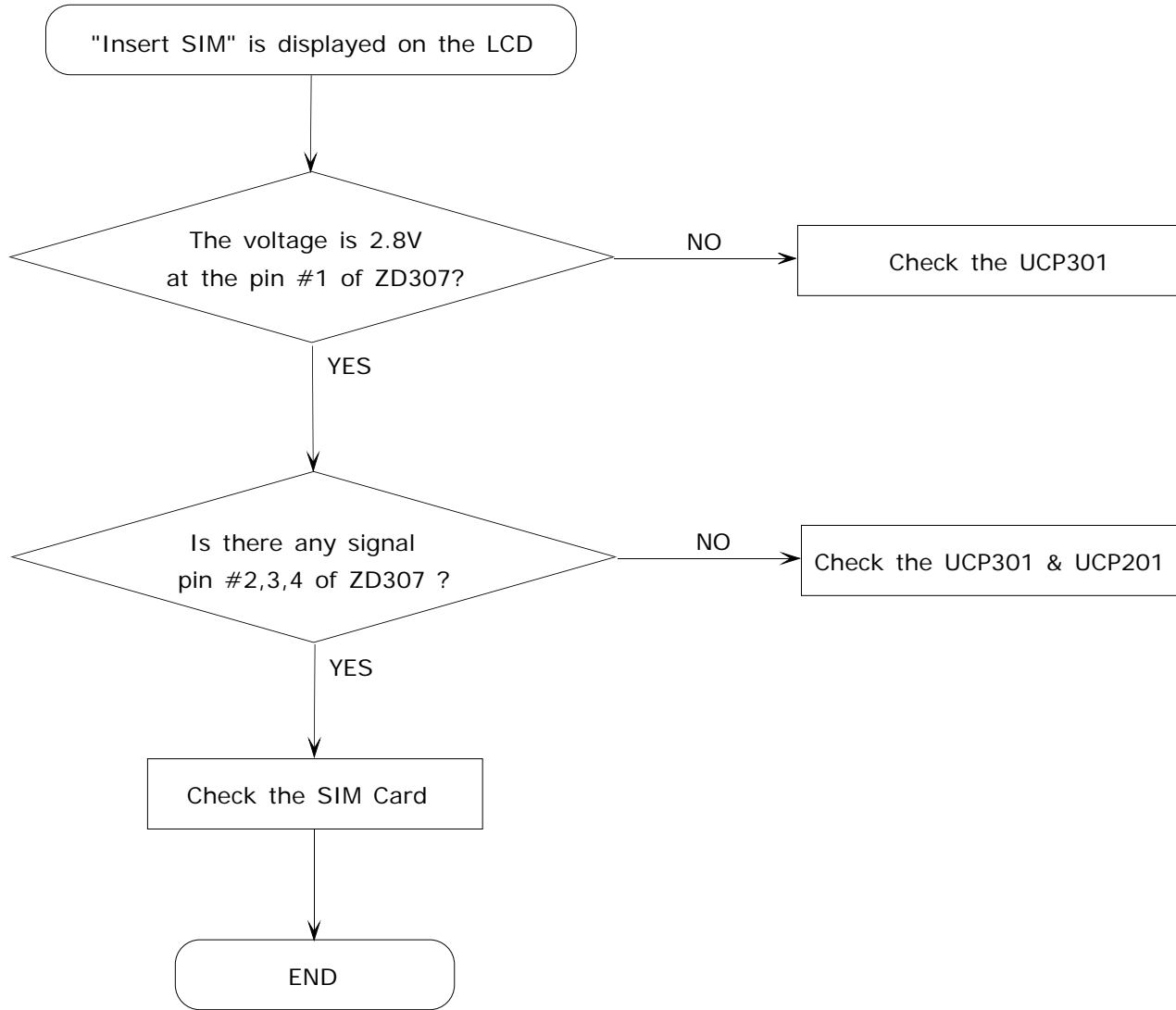

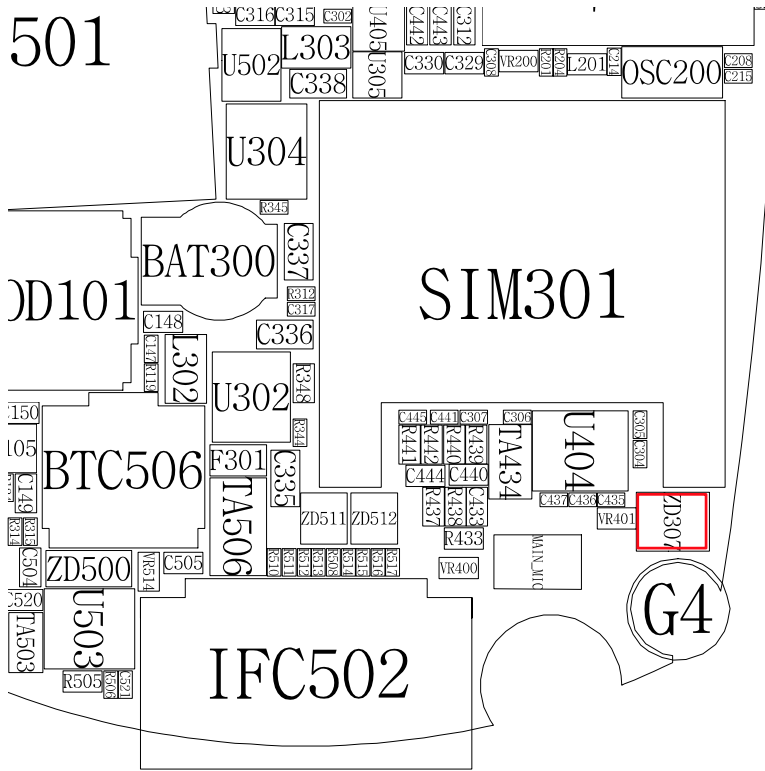
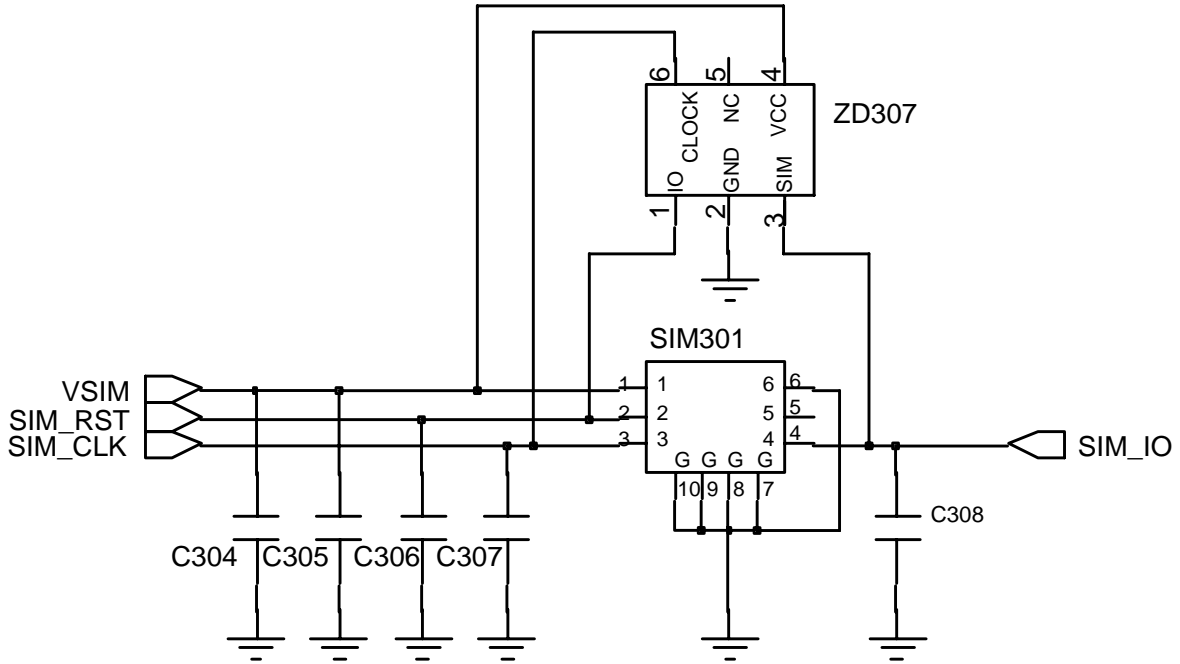

2-1-4. Microphone Part

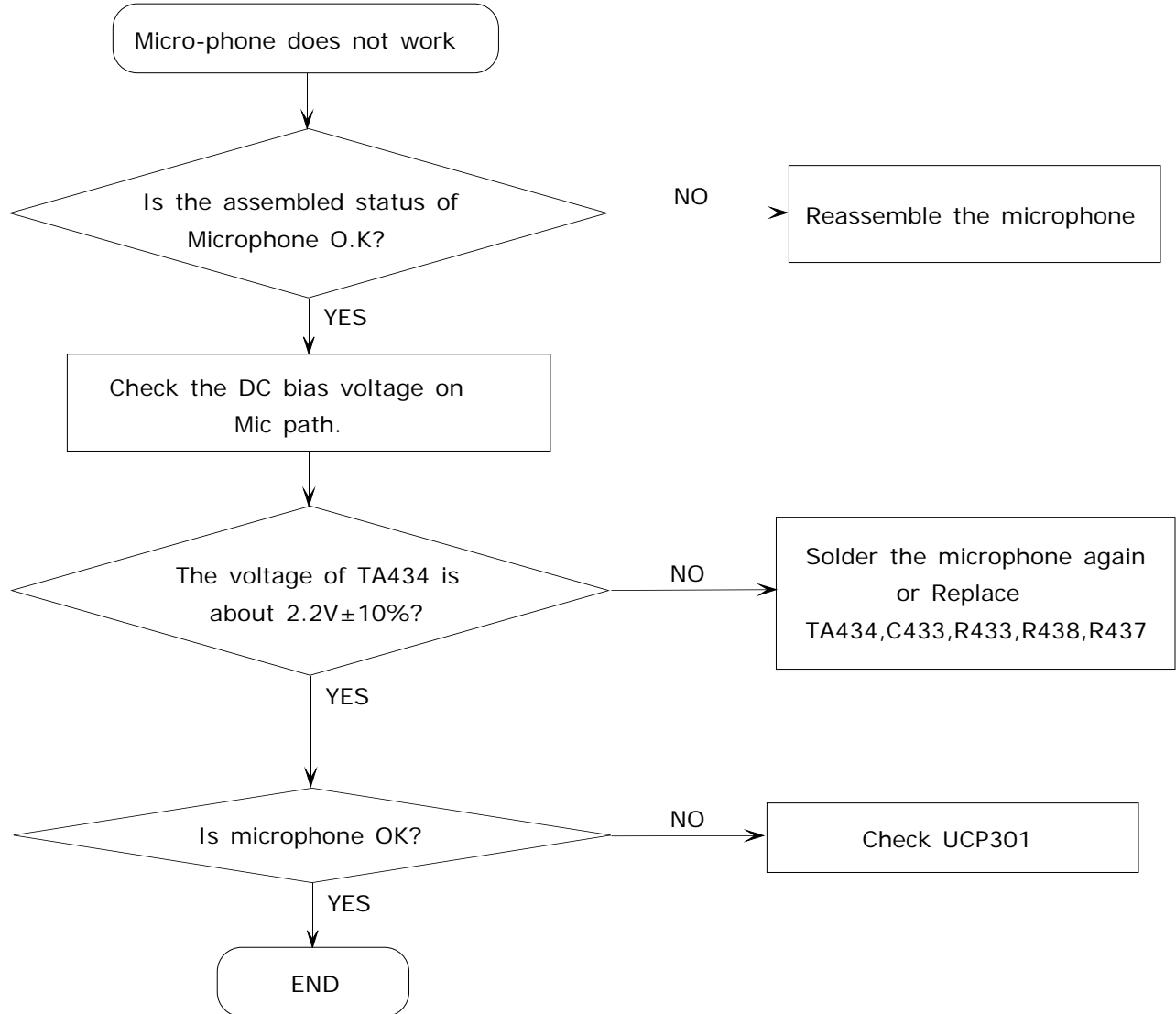

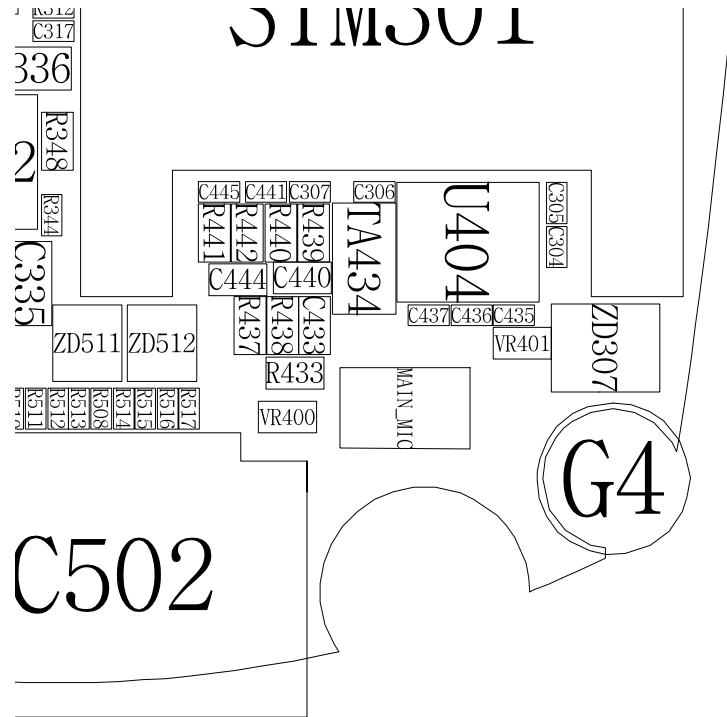
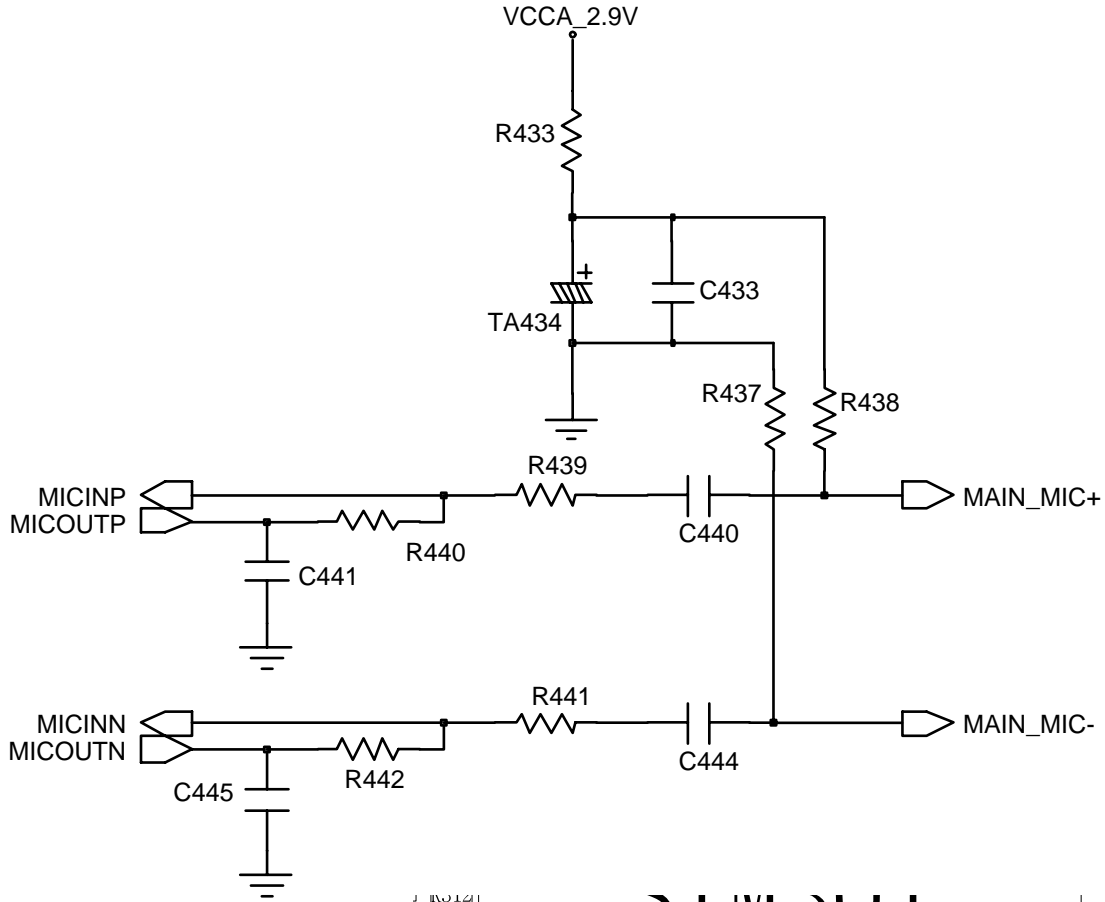

2-1-5. Speaker Part

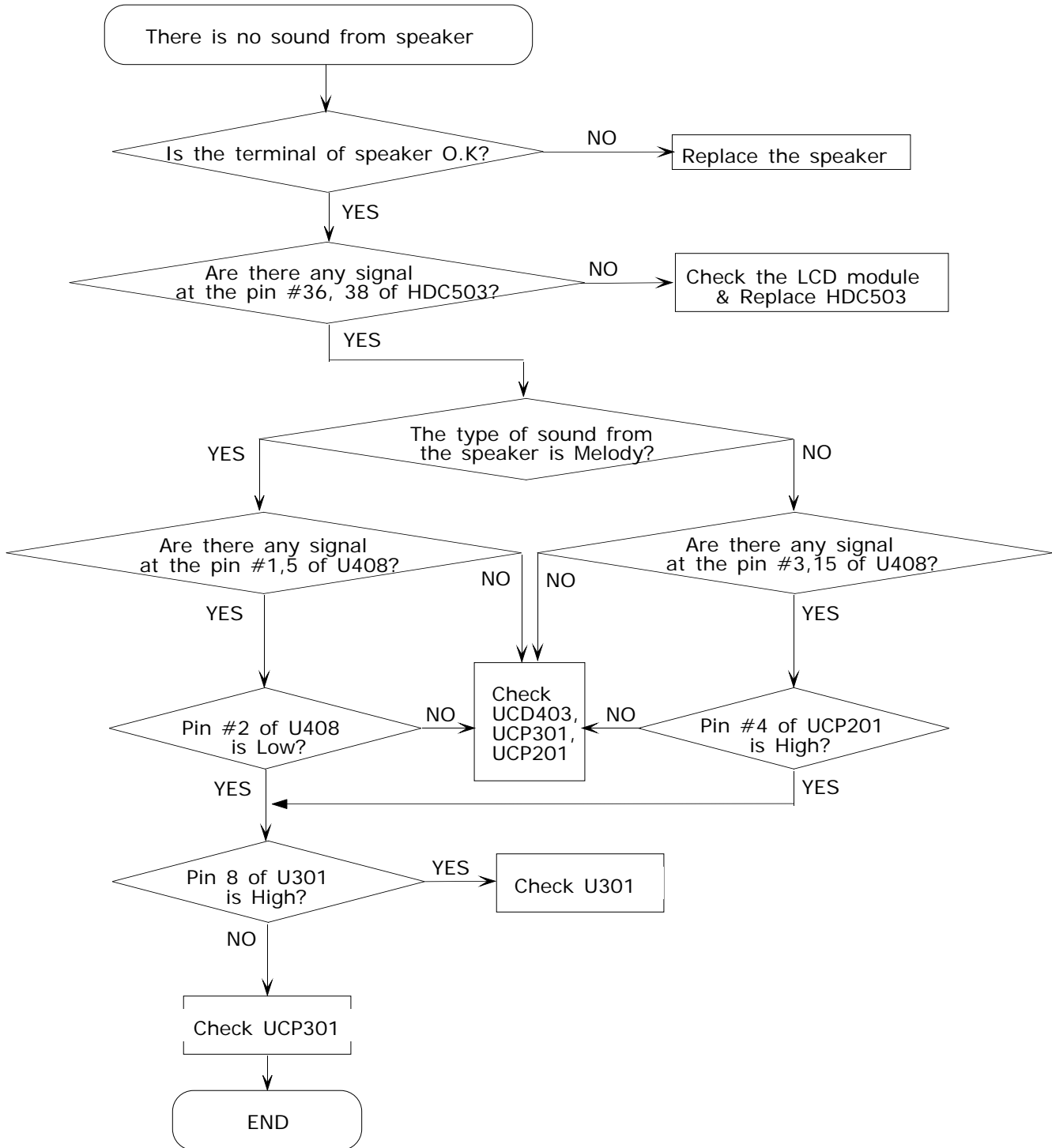

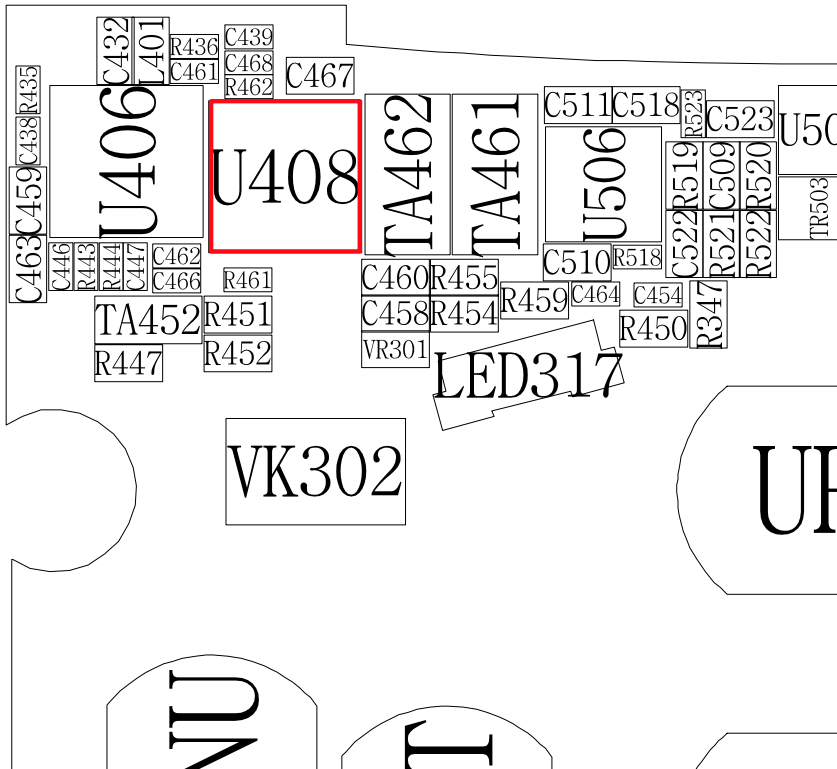
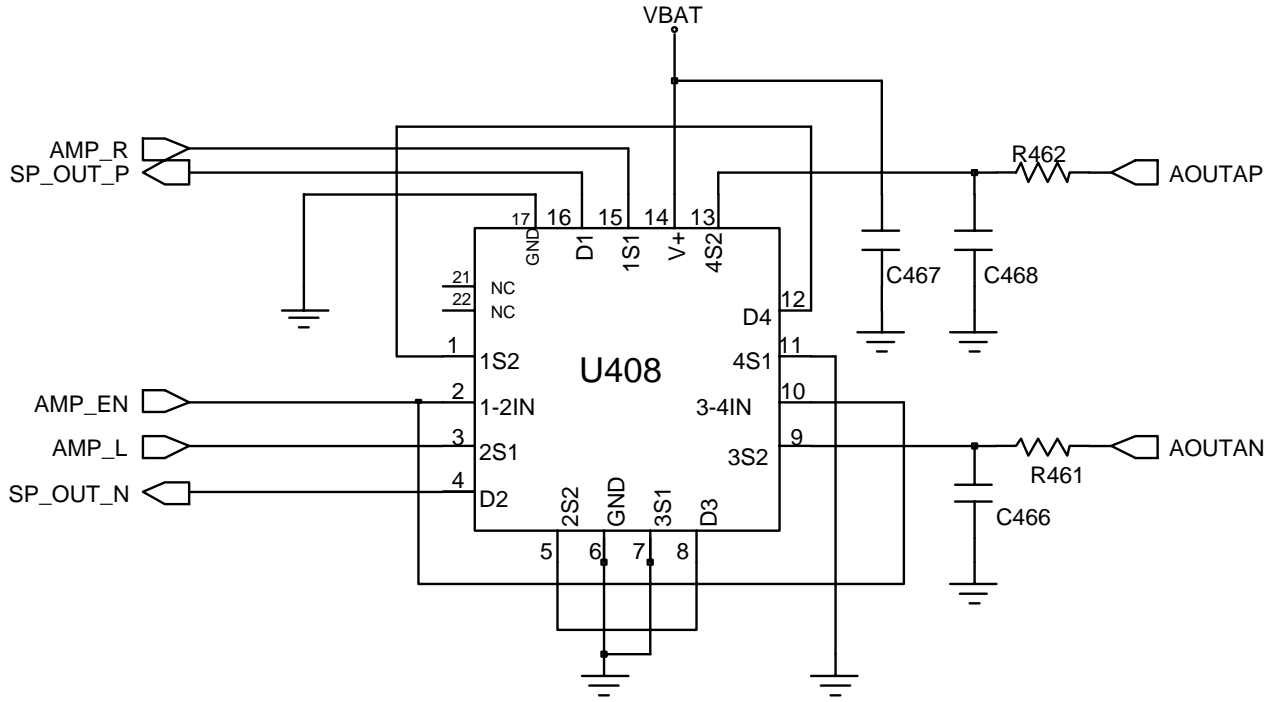

2-1-6. Camera Part

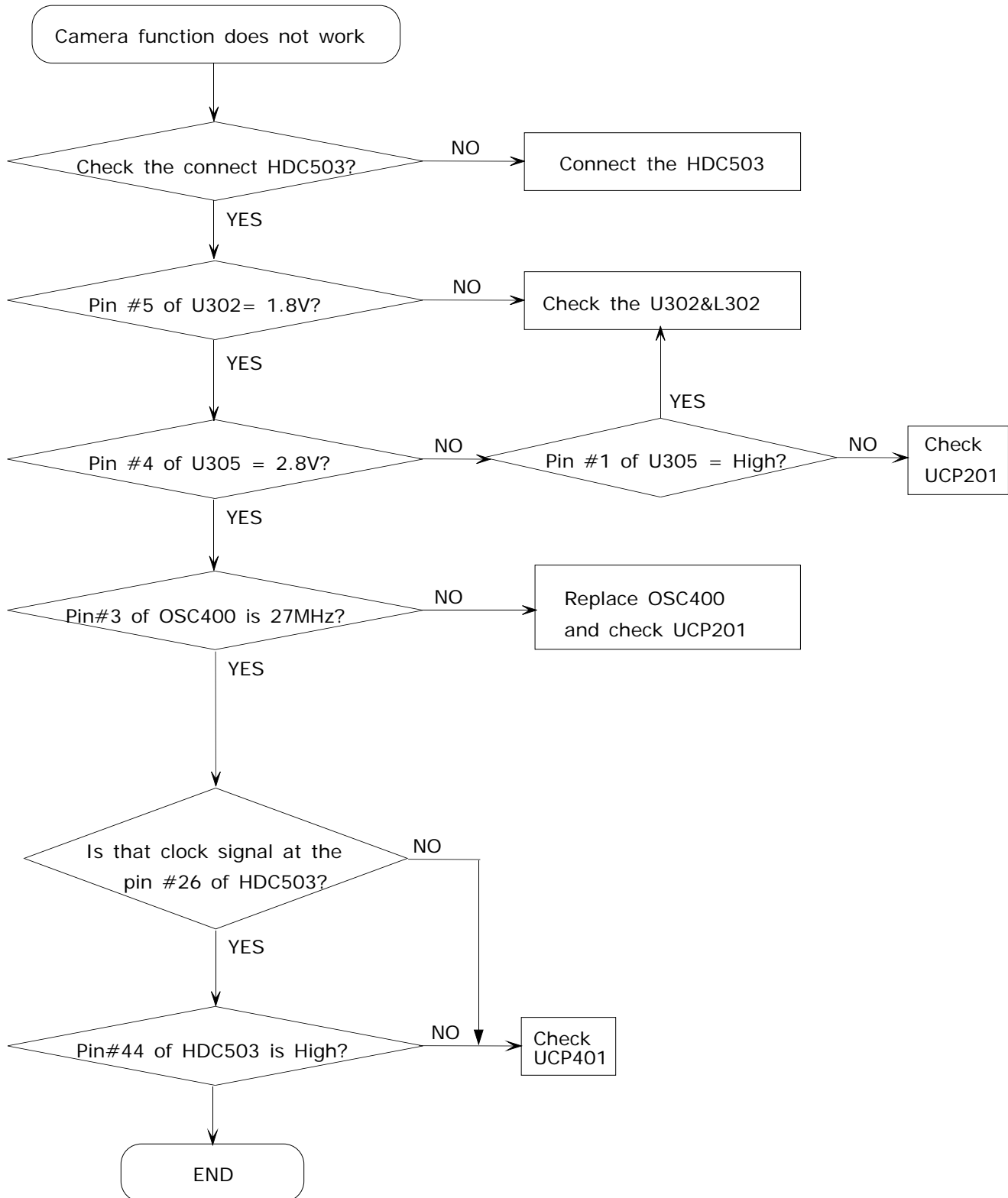

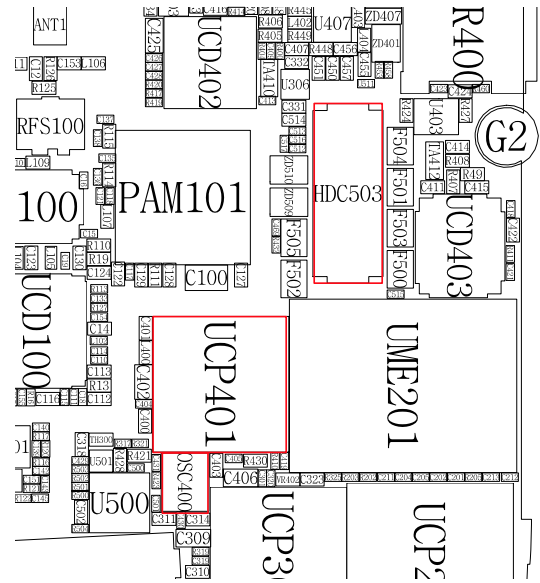
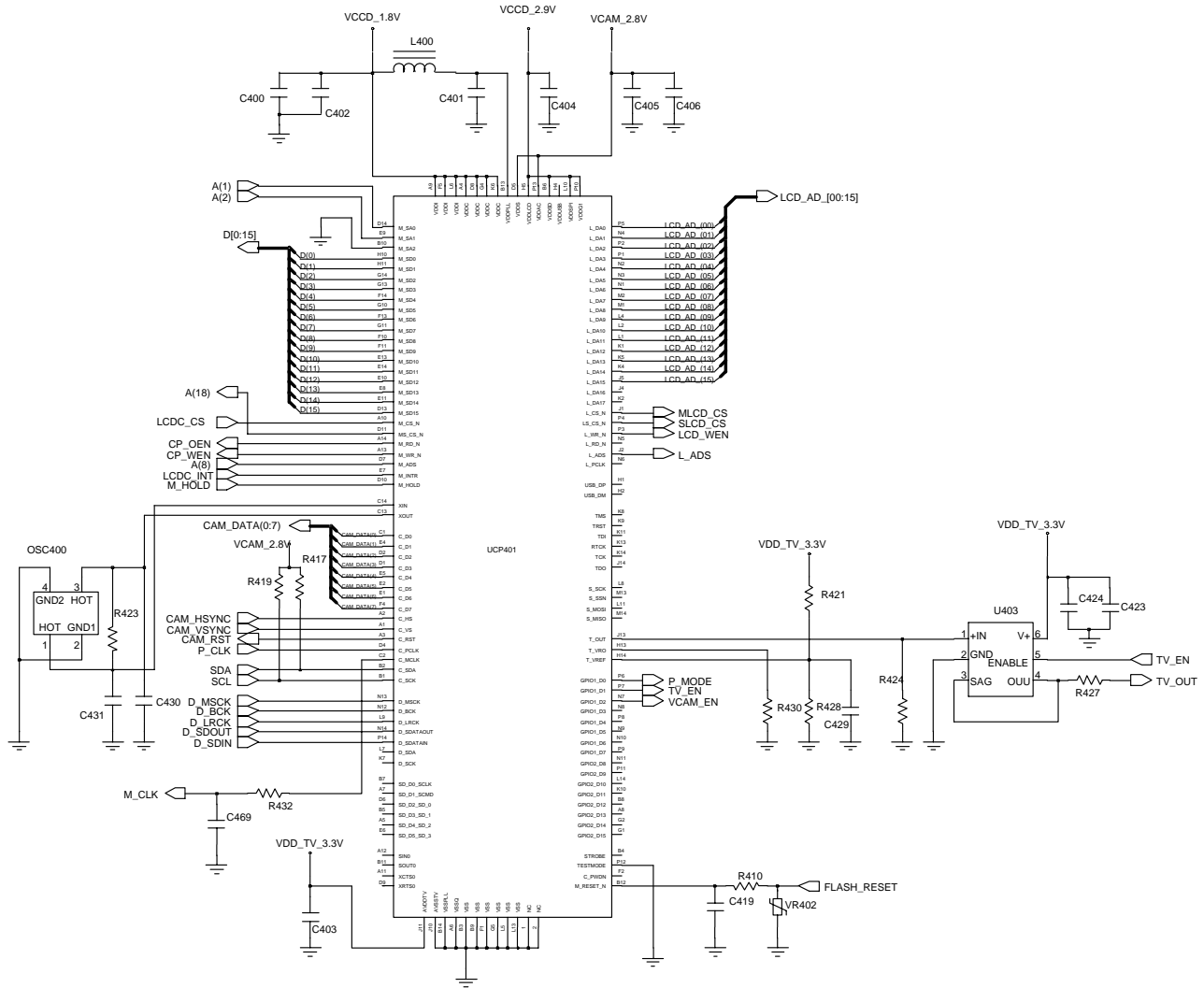

2-1-7. Mp3 Display Part

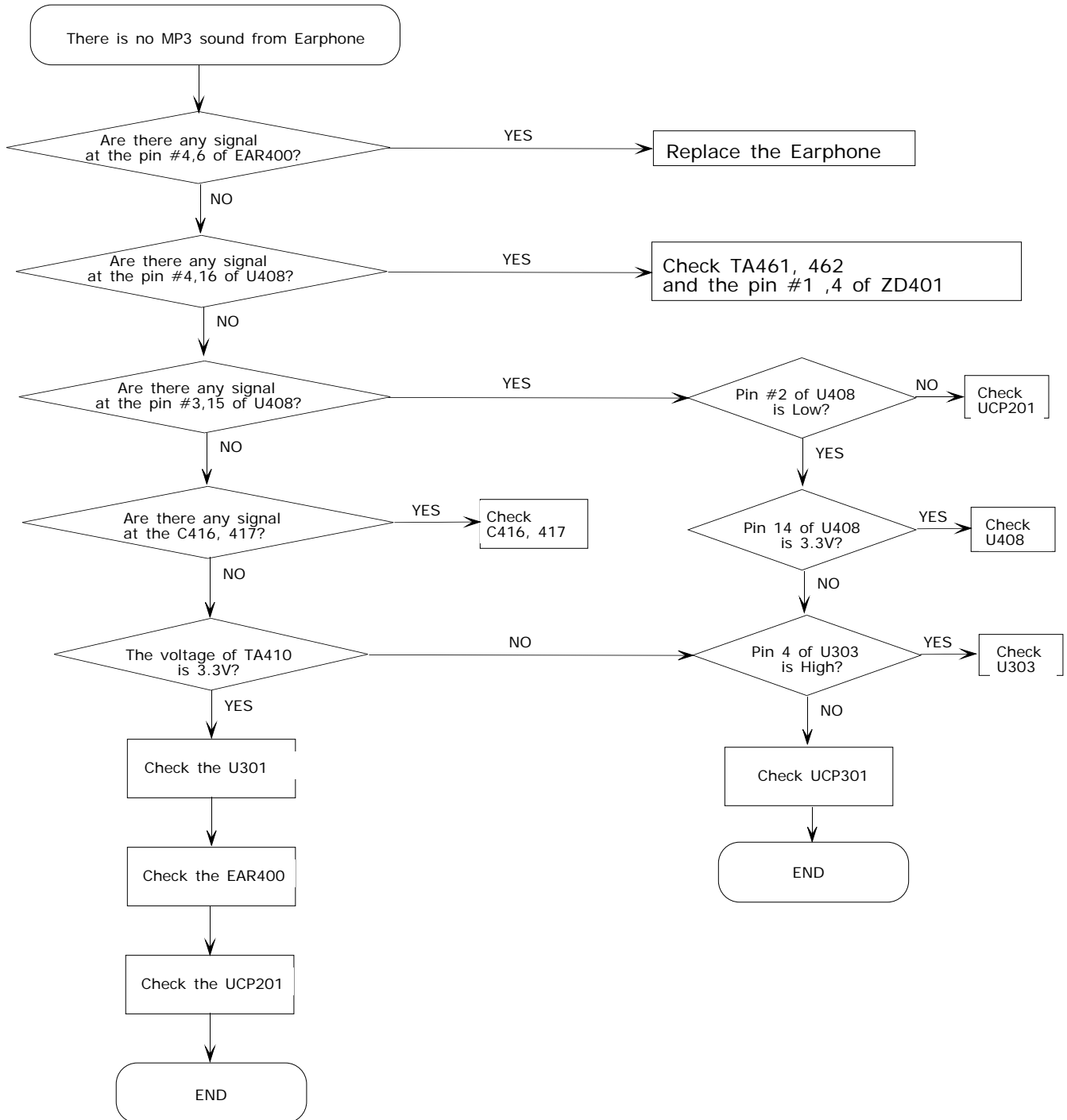

2-2.RF

2-2-1. EGSM RX

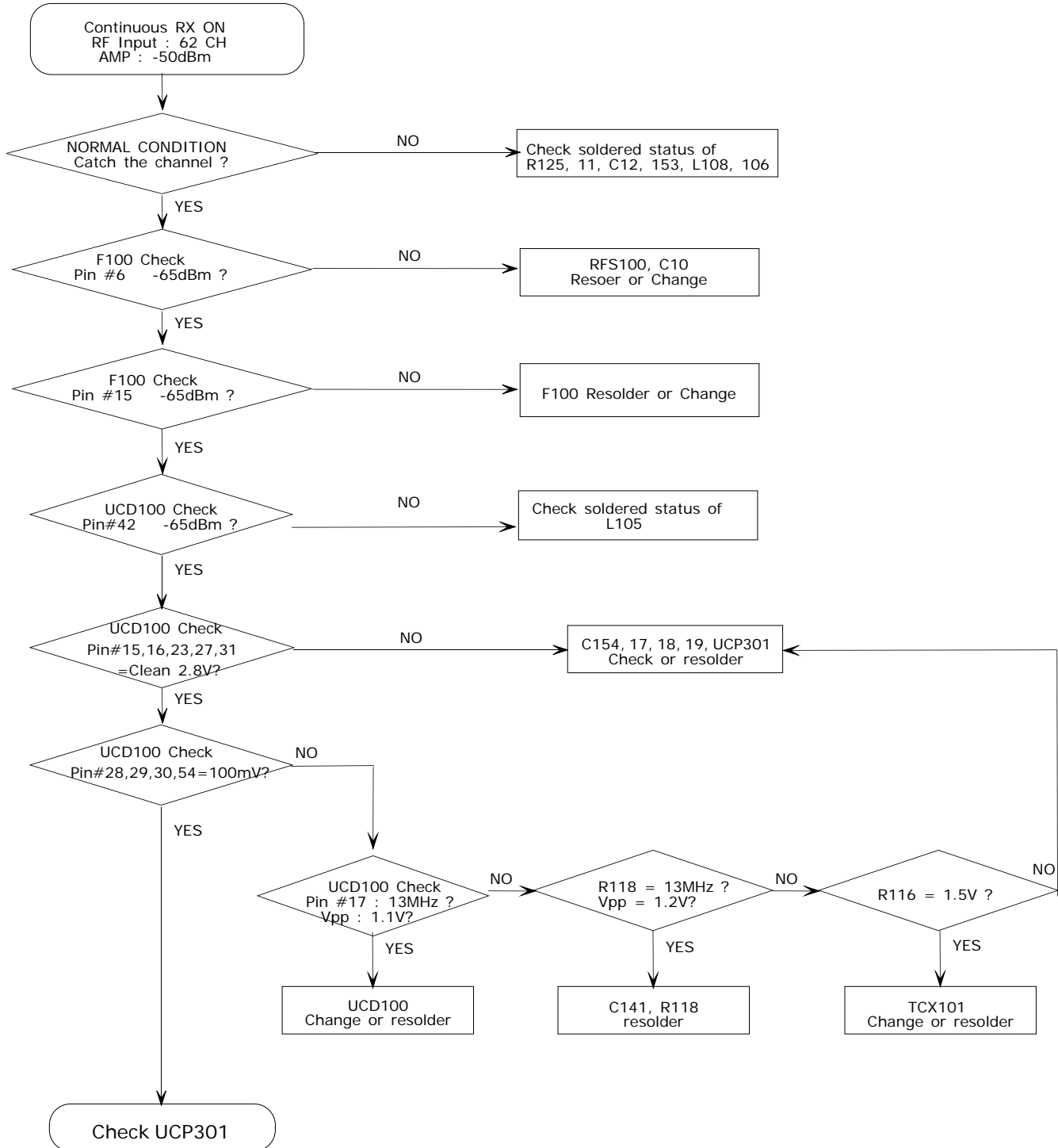

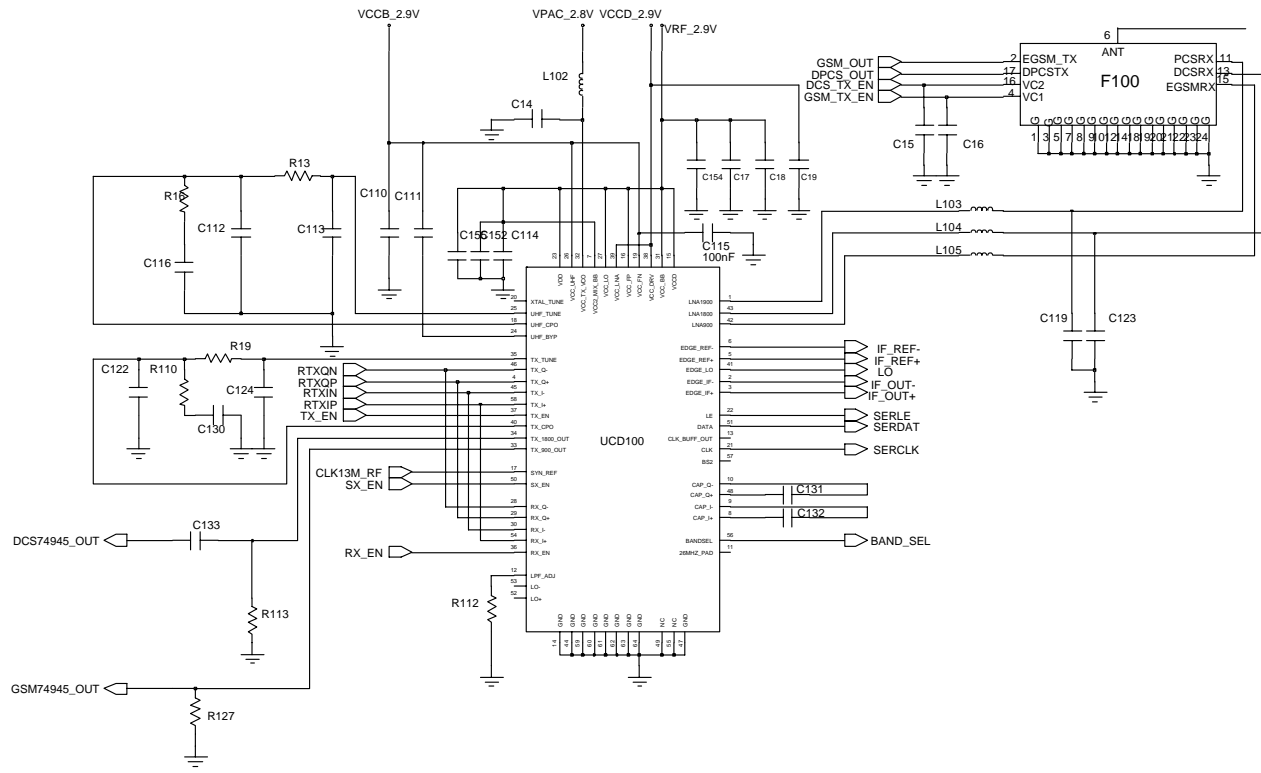

2-2-2. DCS RX

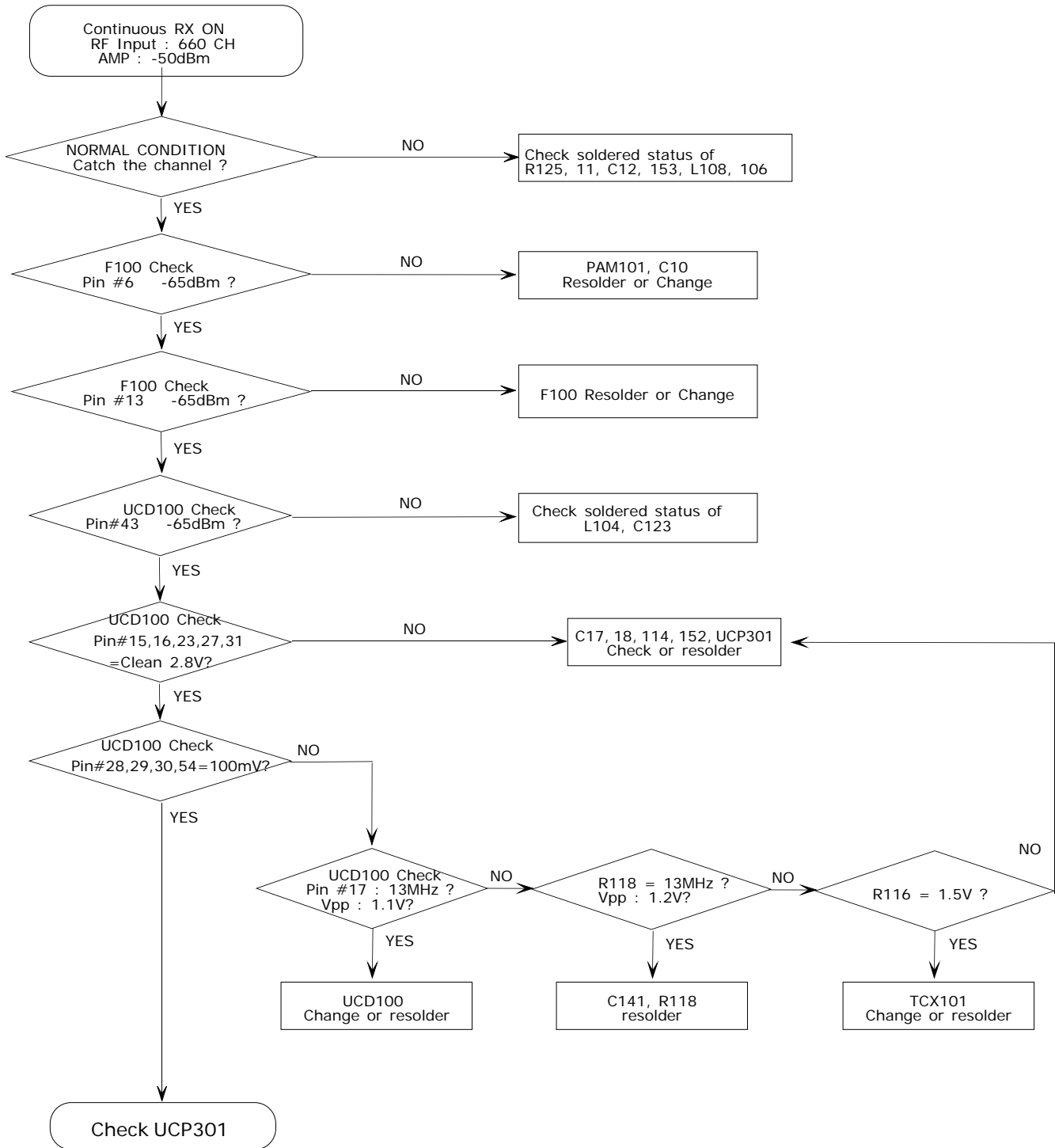

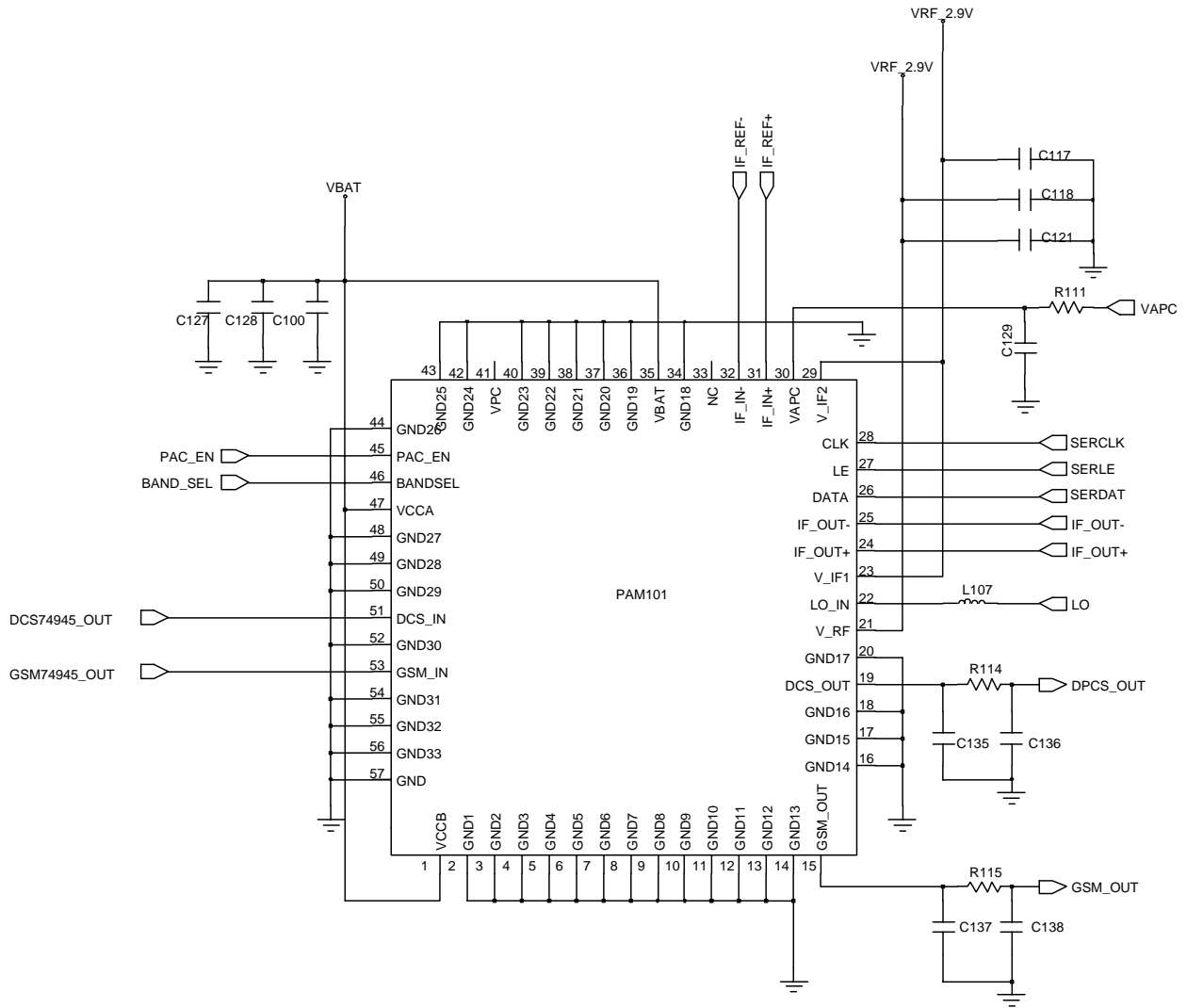

2-2-3. PCS RX

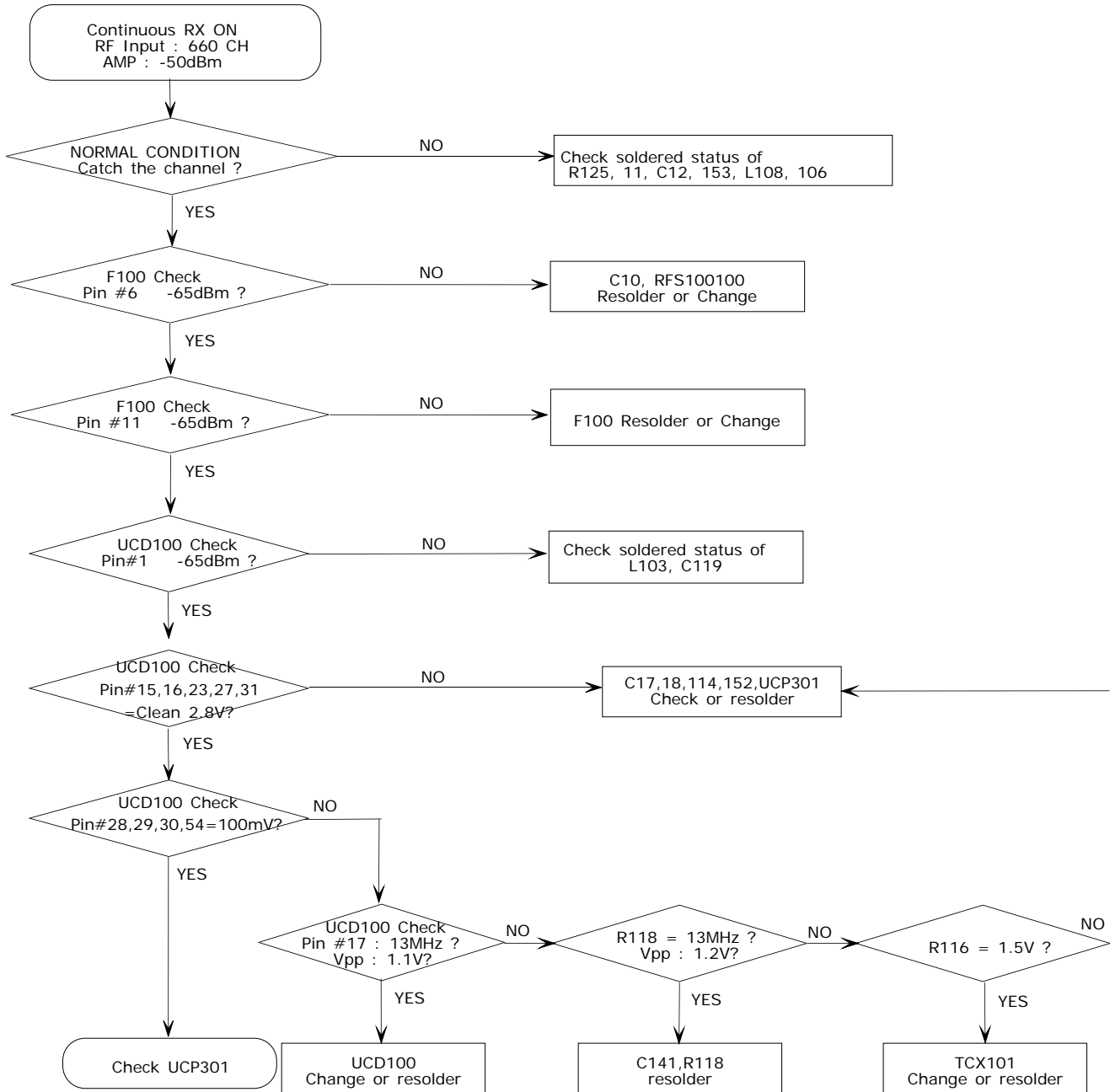

2-2-4. EGSM TX

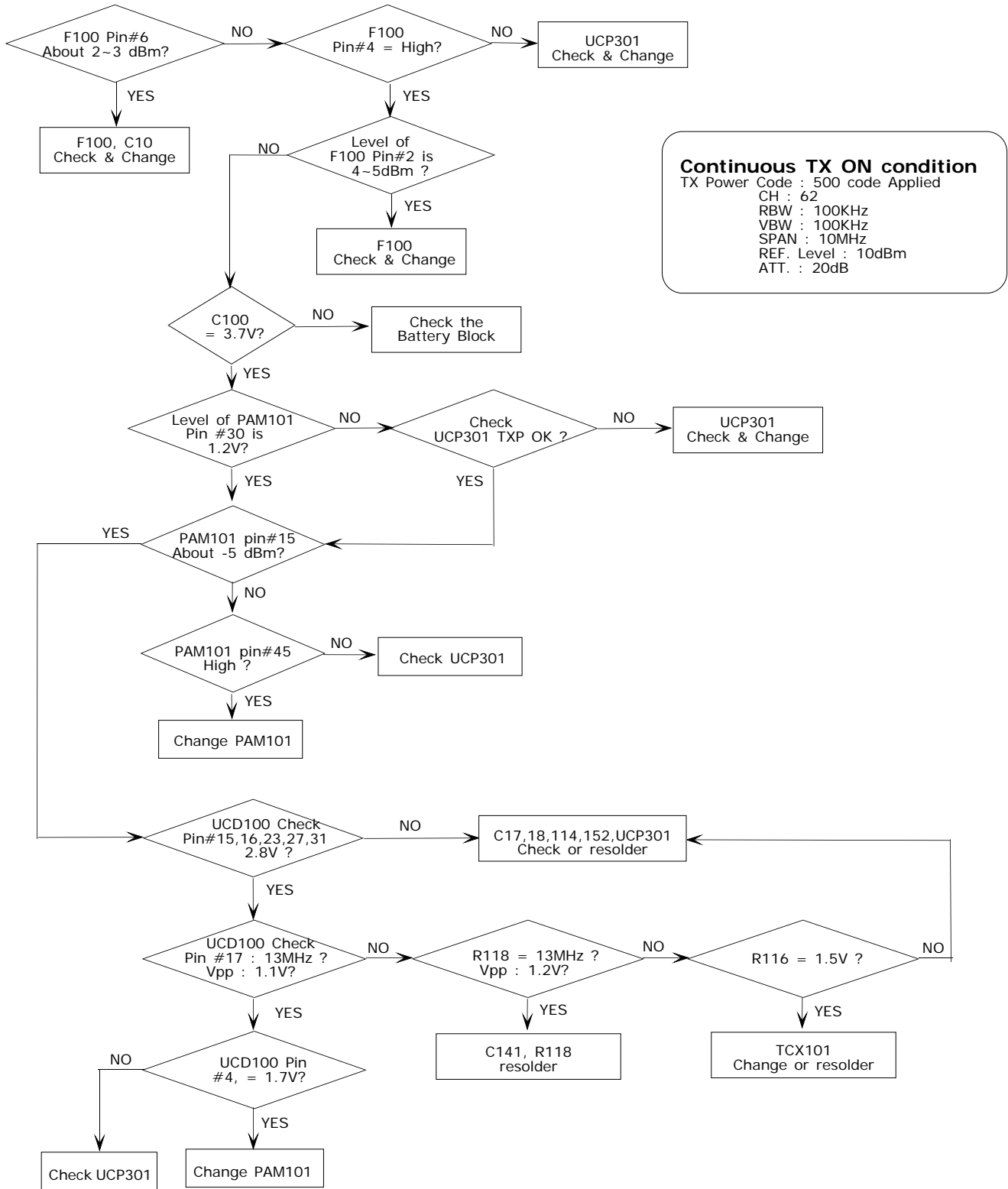

Continuous TX ON condition
 TX Power Code : 500 code Applied
 CH : 62
 RBW : 100KHz
 VBW : 100KHz
 SPAN : 10MHz
 REF. Level : 10dBm
 ATT. : 20dB

2-2-5. DCS & PCS TX

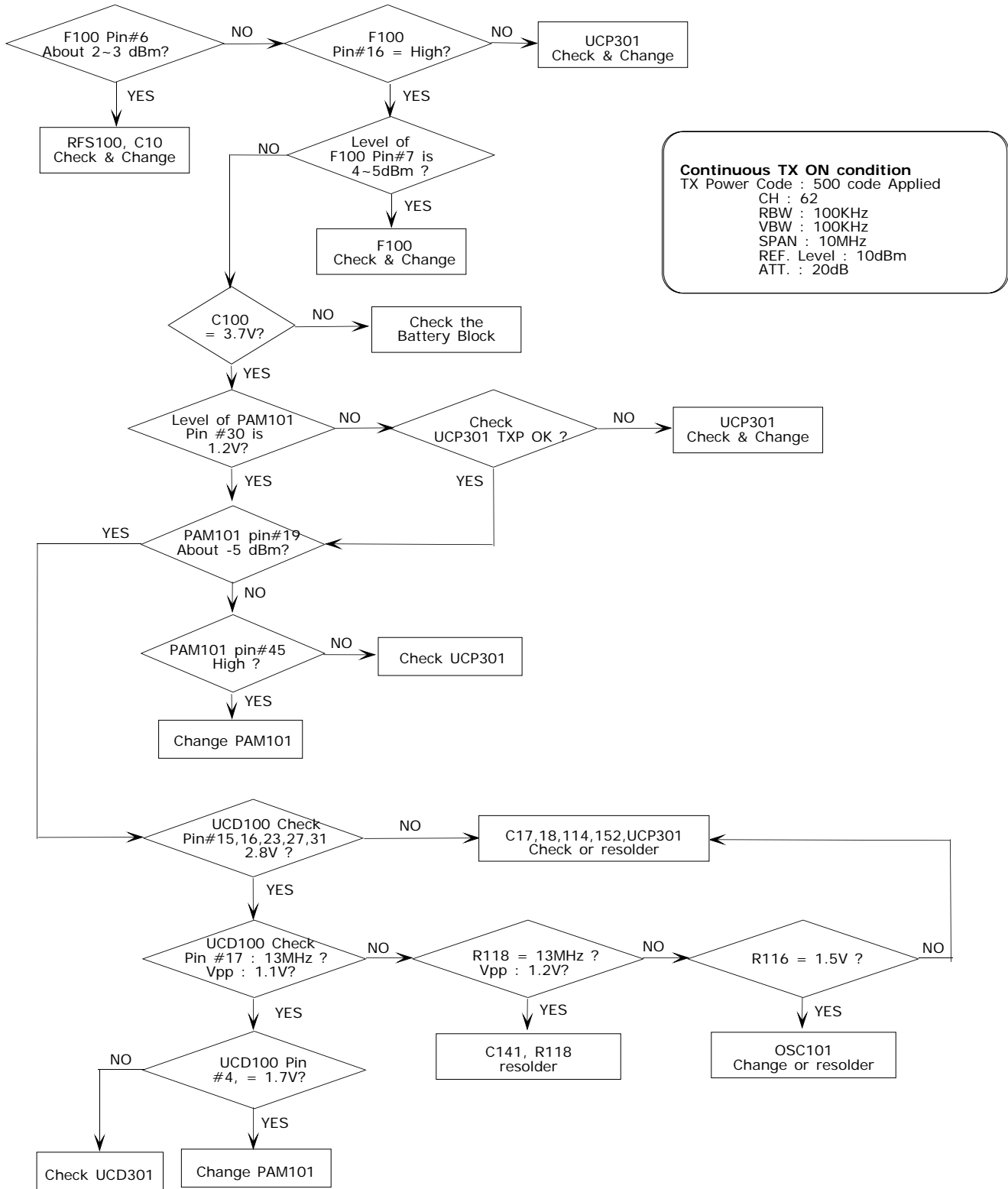

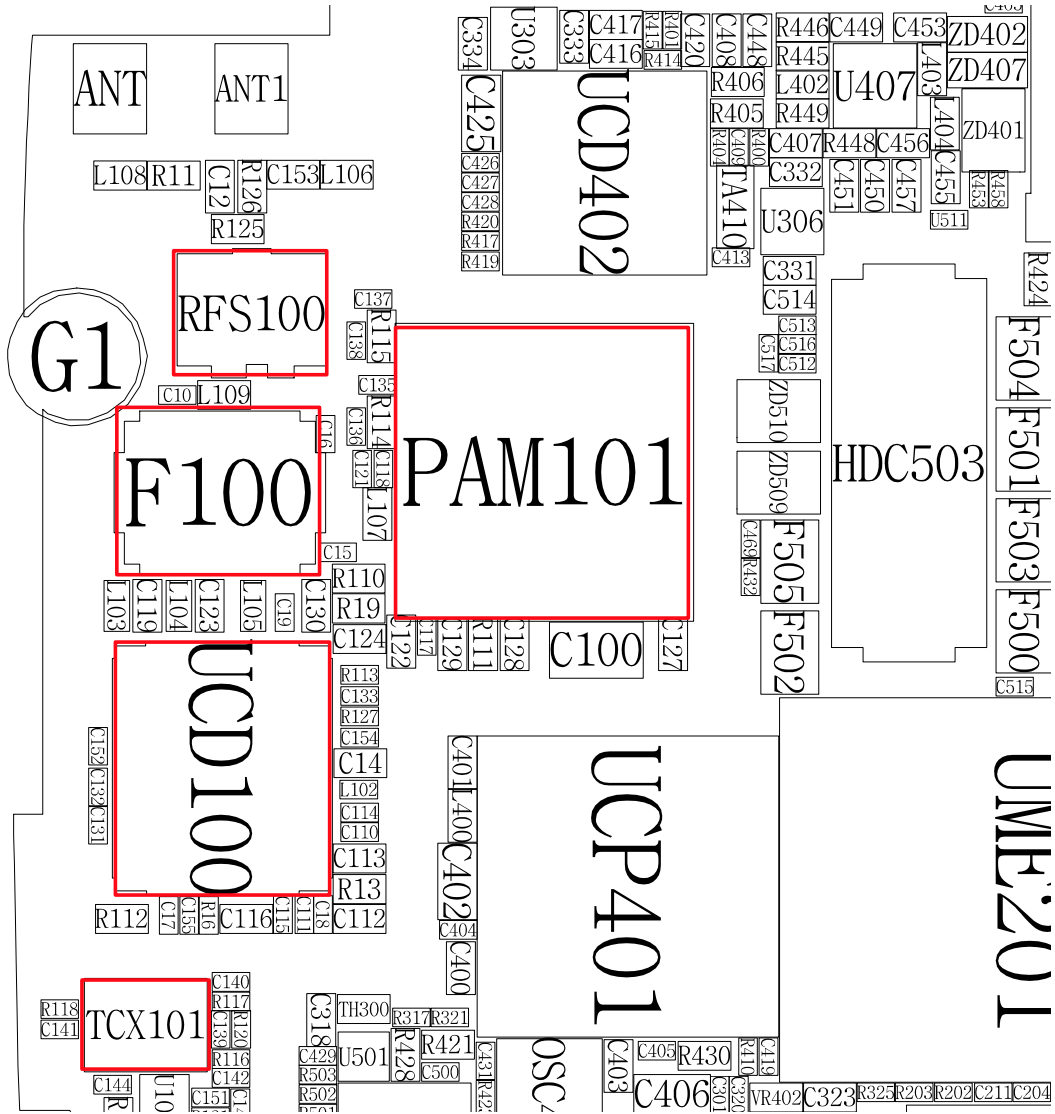

3. SGH-E770 Exploded View and Parts List

3-1. Cellular phone Exploded View

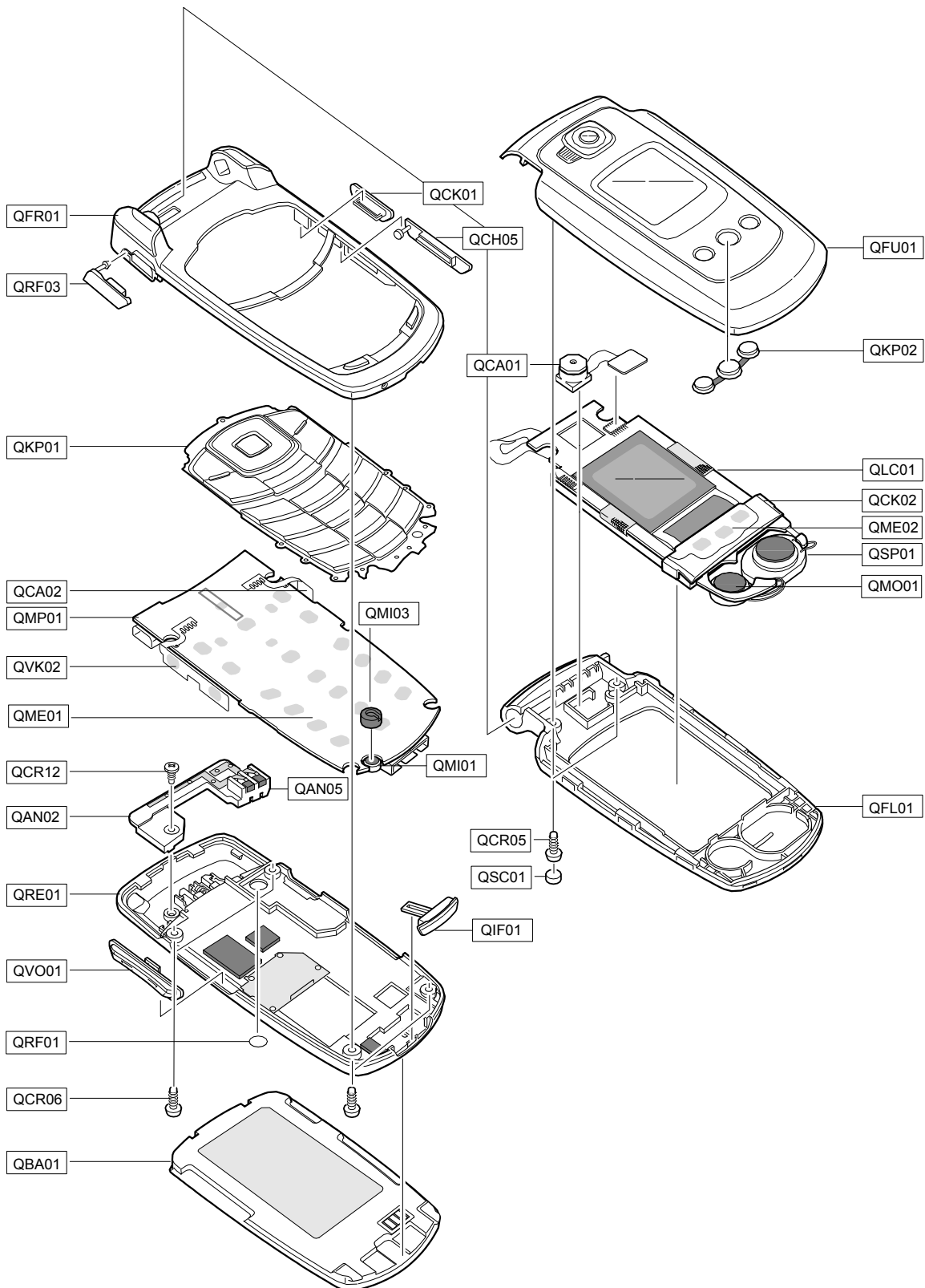

3-2. Cellular phone Parts list

Location NO.		Description	SEC CODE
QAN02		INTENNA-SGHE770	GH42-00660A
QAN05		MEC-INTENNA RUBBER	GH75-07850A
QBA01		BATTERY-780MAH,D/GRAY,EU,M	GH43-02048A
QCA01		UNIT-CAMERA	GH59-02306A
QCA02		UNIT-CAMERA KEY	GH59-02329A
QCK01		MEC-CAMERA KEY	GH75-07742A
QCK02		PMO-MP3 KEY BRACKET	GH72-24482A
QCR05		SCREW-MACHINE	6001-001478
QCR06		SCREW-MACHINE	6001-001155
QCR12		SCREW-MACHINE	6001-001530
QFL01		MEC-FOLDER LOWER	GH75-07598A
QFU01		MEC-FOLDER UPPER	GH75-07597A
QIF01		PMO-IF COVER	GH72-24100A
QKP01		MEC-KEYPAD	GH75-07740A
QKP02		MEC-KEY FOLD(MP3)	GH75-08029A
QLC01		LCD-SGHE770 MODULE	GH07-00758A
QME01		UNIT-METAL DOME	GH59-02327A
QME02		UNIT-MP3 KEY	GH59-02330A
QMI01		MICROPHONE-ASSY-5.25MM	GH30-00177C
QMI03		RMO-MIC HOLDER	GH73-05204A
QMO01		MOTOR DC-SGHE770	GH31-00192A
QMP01		PBA MAIN-SGHE770	GH92-02277A
QRE01		MEC-REAR COVER	GH75-07600A
QRF01		MPR-TAPE SHEET RF	GH74-17200A
QSC01		RMO-SCREW CAP	GH73-05203A
QSP01		SPEAKER	3001-001838
QVK02		UNIT-VOLUME KEY	GH59-02328A
QVO01		MEC-VOLUME KEY	GH75-07741A
QFR01		MEC-FRONT COVER	GH75-07599A
	QRF03	PMO-EAR JACK COVER	GH72-24092A
	QCH05	PMO-TRANS FLASH COVER	GH72-24095A

Description	SEC CODE
BAG PE	6902-000634
ADAPTOR-TAD	GH44-00482A
UNIT-EARPHONE	GH59-02320B
LABEL(P)-WATER SOAK	GH68-02026A
MANUAL-USER	GH68-07948A
LABEL(P)-MAIN	GH68-08026A
BOX(P)-UNIT MAIN	GH69-03239A
CUSHION-CASE TA2 MA2	GH69-03240A
RMO-RUBBER PCB V3	GH73-05392A
RMO-RUBBER PCB V4	GH73-05393A
MPR-BOHO VINYL SUB WIN	GH74-12175A
MPR-BACKUP INSULAT TAPE	GH74-12300A
MPR-BOHO VINYL LCD CONN	GH74-15350A
MPR-TAPE FRONT FPCB MASK	GH74-17203A
MPR-SHIELD LCD FPCB	GH74-17214A
MPR-SHIELD TAPE PCB V2	GH74-18117A
MPR-TAPE LED V4	GH74-18434A
MPR-BOHO VINYL F/UPPER	GH74-18672A
MPR-BOHO VINYL REARCOVER	GH74-18674A
MPR-TAPE MP3 FPCB	GH74-19475A
MPR-VINYL BOHO F/LOWER 2	GH74-19717A
MPR-VINYL BOHO MAIN WIN	GH74-20547A
MEC-HAND STRAP	GH75-03207Q

3-3. Test Jig (GH80-03307A)

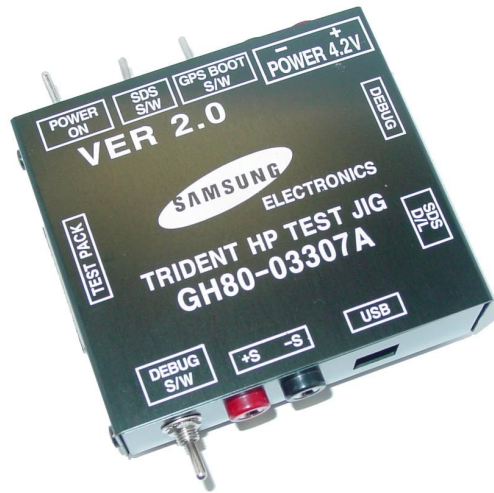

3-3-1. RF Test Cable
(GH39-00283A)



3-3-2. Test Cable
(GH39-00127A)



3-3-3. Serial Cable



3-3-4. Power Supply Cable



3-3-5. DATA CABLE
(GH39-00355A)



3-3-6. TA
(GH44-00482A)



4. SGH-E770 MAIN Electrical Parts List

SEC Code	Design LOC	Discription	STATUS
0403-001427	ZD501	DIODE-ZENER	SA
0403-001547	ZD301	DIODE-ZENER	SA
0403-001547	ZD500	DIODE-ZENER	SA
0406-001150	ZD402	DIODE-TVS	SA
0406-001150	ZD407	DIODE-TVS	SA
0406-001197	ZD511	DIODE-TVS	SA
0406-001197	ZD512	DIODE-TVS	SA
0406-001200	U502	DIODE-TVS	SA
0406-001200	ZD307	DIODE-TVS	SA
0406-001208	ZD401	DIODE-TVS	SA
0406-001208	ZD509	DIODE-TVS	SA
0406-001208	ZD510	DIODE-TVS	SA
0504-001211	TR502	TR-DIGITAL	SA
0504-001211	TR503	TR-DIGITAL	SA
0601-002119	LED316	LED	SA
0601-002119	LED317	LED	SA
0801-002529	U504	IC-CMOS LOGIC	SA
0801-002958	U104	IC-CMOS LOGIC	SA
0801-002958	U501	IC-CMOS LOGIC	SA
0801-003026	U505	IC-CMOS LOGIC	SA
0801-003037	U508	IC-CMOS LOGIC	SA
1001-001306	U406	IC-ANALOG MULTIPLEX	SA
1001-001306	U408	IC-ANALOG MULTIPLEX	SA
1001-001348	U404	IC-ANALOG SWITCH	SA
1009-001018	U203	IC-HALL EFFECT S/W	SA
1108-000024	UME201	IC-MCP	SA
1201-002147	U403	IC-VIDEO AMP	SA
1201-002233	U407	IC-AUDIO AMP	SA
1201-002284	U506	IC-AUDIO AMP	SA
1201-002294	PAM101	IC-POWER AMP	SA
1203-003109	U503	IC-BATTERY	SA
1203-003428	U302	IC-DC/DC CONVERTER	SA
1203-003432	U105	IC-POSI.FIXED REG.	SA
1203-003432	U306	IC-POSI.FIXED REG.	SA
1203-003523	U303	IC-POSI.FIXED REG.	SA

SEC Code	Design LOC	Discription	STATUS
1203-003523	U305	IC-POSI.FIXED REG.	SA
1203-003523	U507	IC-POSI.FIXED REG.	SA
1203-003565	UCP301	IC-POWER SUPERVISOR	SA
1203-003612	U304	IC-DC/DC CONVERTER	SA
1203-003737	U405	IC-POSI.FIXED REG.	SA
1203-003789	U500	IC-POWER SUPERVISOR	SA
1204-002138	UCD403	IC-MELODY	SA
1205-002272	U301	IC-TRANSCEIVER	SA
1205-002681	UCD402	IC-CODEC	SA
1205-002821	UCD100	IC-TRANSCEIVER	SA
1205-002834	UCP401	IC-CODEC	SA
1404-001165	TH300	THERMISTOR-NTC	SA
1405-001082	VF311	VARISTOR	SA
1405-001082	VR200	VARISTOR	SA
1405-001082	VR301	VARISTOR	SA
1405-001082	VR302	VARISTOR	SA
1405-001082	VR303	VARISTOR	SA
1405-001082	VR304	VARISTOR	SA
1405-001082	VR305	VARISTOR	SA
1405-001082	VR306	VARISTOR	SA
1405-001082	VR307	VARISTOR	SA
1405-001082	VR308	VARISTOR	SA
1405-001082	VR309	VARISTOR	SA
1405-001082	VR310	VARISTOR	SA
1405-001082	VR400	VARISTOR	SA
1405-001082	VR401	VARISTOR	SA
1405-001082	VR514	VARISTOR	SA
2007-000138	R19	R-CHIP	SA
2007-000142	R505	R-CHIP	SA
2007-000162	R200	R-CHIP	SA
2007-000171	R114	R-CHIP	SA
2007-000171	R115	R-CHIP	SA
2007-000171	R463	R-CHIP	SA
2007-000758	R123	R-CHIP	SA
2007-000775	R408	R-CHIP	SA

SEC Code	Design LOC	Discription	STATUS
2007-000775	R49	R-CHIP	SA
2007-000982	R13	R-CHIP	SA
2007-001119	R433	R-CHIP	SA
2007-001119	R447	R-CHIP	SA
2007-001288	R346	R-CHIP	SA
2007-001288	R347	R-CHIP	SA
2007-001306	R424	R-CHIP	SA
2007-007009	R427	R-CHIP	SA
2007-007014	R519	R-CHIP	SA
2007-007014	R521	R-CHIP	SA
2007-007095	R110	R-CHIP	SA
2007-007134	R112	R-CHIP	SA
2007-007142	R111	R-CHIP	SA
2007-007142	R428	R-CHIP	SA
2007-007142	R439	R-CHIP	SA
2007-007142	R441	R-CHIP	SA
2007-007142	R454	R-CHIP	SA
2007-007142	R455	R-CHIP	SA
2007-007142	R520	R-CHIP	SA
2007-007142	R522	R-CHIP	SA
2007-007308	R445	R-CHIP	SA
2007-007308	R449	R-CHIP	SA
2007-007309	R446	R-CHIP	SA
2007-007309	R448	R-CHIP	SA
2007-007312	R421	R-CHIP	SA
2007-007334	R407	R-CHIP	SA
2007-007488	R440	R-CHIP	SA
2007-007488	R442	R-CHIP	SA
2007-007528	R437	R-CHIP	SA
2007-007528	R438	R-CHIP	SA
2007-007528	R451	R-CHIP	SA
2007-007528	R452	R-CHIP	SA
2007-007529	R450	R-CHIP	SA
2007-007529	R459	R-CHIP	SA
2007-007588	R430	R-CHIP	SA

SEC Code	Design LOC	Discription	STATUS
2007-007798	R405	R-CHIP	SA
2007-007798	R406	R-CHIP	SA
2007-008040	R436	R-CHIP	SA
2007-008040	R444	R-CHIP	SA
2007-008040	R461	R-CHIP	SA
2007-008040	R462	R-CHIP	SA
2007-008043	R435	R-CHIP	SA
2007-008043	R443	R-CHIP	SA
2007-008045	R118	R-CHIP	SA
2007-008045	R122	R-CHIP	SA
2007-008045	R315	R-CHIP	SA
2007-008049	R16	R-CHIP	SA
2007-008051	R411	R-CHIP	SA
2007-008052	R319	R-CHIP	SA
2007-008055	R203	R-CHIP	SA
2007-008055	R204	R-CHIP	SA
2007-008055	R205	R-CHIP	SA
2007-008055	R509	R-CHIP	SA
2007-008055	R525	R-CHIP	SA
2007-008210	R400	R-CHIP	SA
2007-008210	R401	R-CHIP	SA
2007-008419	R414	R-CHIP	SA
2007-008419	R415	R-CHIP	SA
2007-008419	R510	R-CHIP	SA
2007-008419	R511	R-CHIP	SA
2007-008419	R512	R-CHIP	SA
2007-008419	R513	R-CHIP	SA
2007-008419	R514	R-CHIP	SA
2007-008419	R515	R-CHIP	SA
2007-008419	R516	R-CHIP	SA
2007-008419	R524	R-CHIP	SA
2007-008420	R310	R-CHIP	SA
2007-008420	R336	R-CHIP	SA
2007-008420	R337	R-CHIP	SA
2007-008420	R432	R-CHIP	SA

SEC Code	Design LOC	Discription	STATUS
2007-008478	R333	R-CHIP	SA
2007-008483	R119	R-CHIP	SA
2007-008483	R202	R-CHIP	SA
2007-008483	R330	R-CHIP	SA
2007-008483	R416	R-CHIP	SA
2007-008483	R464	R-CHIP	SA
2007-008483	R500	R-CHIP	SA
2007-008483	R501	R-CHIP	SA
2007-008483	R502	R-CHIP	SA
2007-008483	R506	R-CHIP	SA
2007-008483	R508	R-CHIP	SA
2007-008486	R503	R-CHIP	SA
2007-008516	R117	R-CHIP	SA
2007-008516	R201	R-CHIP	SA
2007-008516	R314	R-CHIP	SA
2007-008516	R420	R-CHIP	SA
2007-008516	R517	R-CHIP	SA
2007-008516	R526	R-CHIP	SA
2007-008531	R116	R-CHIP	SA
2007-008531	R404	R-CHIP	SA
2007-008542	R311	R-CHIP	SA
2007-008542	R349	R-CHIP	SA
2007-008542	R458	R-CHIP	SA
2007-008542	R460	R-CHIP	SA
2007-008542	R504	R-CHIP	SA
2007-008587	R121	R-CHIP	SA
2007-008588	R312	R-CHIP	SA
2007-008588	R417	R-CHIP	SA
2007-008588	R419	R-CHIP	SA
2007-008800	R527	R-CHIP	SA
2007-009084	R423	R-CHIP	SA
2007-009111	R127	R-CHIP	SA
2007-009157	R518	R-CHIP	SA
2007-009157	R523	R-CHIP	SA
2007-009166	R317	R-CHIP	SA

SEC Code	Design LOC	Discription	STATUS
2007-009167	R321	R-CHIP	SA
2007-009170	R453	R-CHIP	SA
2007-009170	R529	R-CHIP	SA
2007-009199	R113	R-CHIP	SA
2203-000254	C127	C-CER,CHIP	SA
2203-000254	C128	C-CER,CHIP	SA
2203-000254	C509	C-CER,CHIP	SA
2203-000311	C129	C-CER,CHIP	SA
2203-000489	C522	C-CER,CHIP	SA
2203-000489	C523	C-CER,CHIP	SA
2203-000585	C113	C-CER,CHIP	SA
2203-000654	C414	C-CER,CHIP	SA
2203-000725	C130	C-CER,CHIP	SA
2203-000854	C124	C-CER,CHIP	SA
2203-000870	C101	C-CER,CHIP	SA
2203-000995	C209	C-CER,CHIP	SA
2203-001033	C415	C-CER,CHIP	SA
2203-001124	C112	C-CER,CHIP	SA
2203-001124	C453	C-CER,CHIP	SA
2203-001124	C455	C-CER,CHIP	SA
2203-001210	C116	C-CER,CHIP	SA
2203-001405	C318	C-CER,CHIP	SA
2203-001437	C122	C-CER,CHIP	SA
2203-002668	C12	C-CER,CHIP	SA
2203-005057	C153	C-CER,CHIP	SA
2203-005481	C400	C-CER,CHIP	SA
2203-005481	C401	C-CER,CHIP	SA
2203-005481	C411	C-CER,CHIP	SA
2203-005481	C440	C-CER,CHIP	SA
2203-005481	C444	C-CER,CHIP	SA
2203-005682	C145	C-CER,CHIP	SA
2203-005682	C16	C-CER,CHIP	SA
2203-005682	C306	C-CER,CHIP	SA
2203-005682	C307	C-CER,CHIP	SA
2203-005682	C308	C-CER,CHIP	SA

SEC Code	Design LOC	Discription	STATUS
2203-005682	C435	C-CER,CHIP	SA
2203-005682	C437	C-CER,CHIP	SA
2203-005682	C441	C-CER,CHIP	SA
2203-005682	C445	C-CER,CHIP	SA
2203-005682	C469	C-CER,CHIP	SA
2203-005682	C516	C-CER,CHIP	SA
2203-005682	C517	C-CER,CHIP	SA
2203-005683	C436	C-CER,CHIP	SA
2203-005719	C438	C-CER,CHIP	SA
2203-005719	C439	C-CER,CHIP	SA
2203-005719	C446	C-CER,CHIP	SA
2203-005719	C447	C-CER,CHIP	SA
2203-005719	C466	C-CER,CHIP	SA
2203-005719	C468	C-CER,CHIP	SA
2203-005729	C10	C-CER,CHIP	SA
2203-005729	C214	C-CER,CHIP	SA
2203-005729	C215	C-CER,CHIP	SA
2203-005736	C19	C-CER,CHIP	SA
2203-005736	C317	C-CER,CHIP	SA
2203-005736	C521	C-CER,CHIP	SA
2203-005806	C144	C-CER,CHIP	SA
2203-005806	C421	C-CER,CHIP	SA
2203-005806	C454	C-CER,CHIP	SA
2203-005806	C464	C-CER,CHIP	SA
2203-006048	C210	C-CER,CHIP	SA
2203-006048	C321	C-CER,CHIP	SA
2203-006048	C510	C-CER,CHIP	SA
2203-006048	C520	C-CER,CHIP	SA
2203-006091	C448	C-CER,CHIP	SA
2203-006091	C451	C-CER,CHIP	SA
2203-006121	C304	C-CER,CHIP	SA
2203-006123	C133	C-CER,CHIP	SA
2203-006190	C449	C-CER,CHIP	SA
2203-006190	C450	C-CER,CHIP	SA
2203-006194	C110	C-CER,CHIP	SA

SEC Code	Design LOC	Discription	STATUS
2203-006194	C111	C-CER,CHIP	SA
2203-006194	C117	C-CER,CHIP	SA
2203-006194	C118	C-CER,CHIP	SA
2203-006194	C121	C-CER,CHIP	SA
2203-006194	C139	C-CER,CHIP	SA
2203-006194	C140	C-CER,CHIP	SA
2203-006194	C141	C-CER,CHIP	SA
2203-006194	C151	C-CER,CHIP	SA
2203-006194	C152	C-CER,CHIP	SA
2203-006194	C154	C-CER,CHIP	SA
2203-006194	C155	C-CER,CHIP	SA
2203-006194	C201	C-CER,CHIP	SA
2203-006194	C205	C-CER,CHIP	SA
2203-006194	C207	C-CER,CHIP	SA
2203-006194	C213	C-CER,CHIP	SA
2203-006194	C300	C-CER,CHIP	SA
2203-006194	C301	C-CER,CHIP	SA
2203-006194	C320	C-CER,CHIP	SA
2203-006201	C309	C-CER,CHIP	SA
2203-006257	C416	C-CER,CHIP	SA
2203-006257	C417	C-CER,CHIP	SA
2203-006257	C433	C-CER,CHIP	SA
2203-006257	C504	C-CER,CHIP	SA
2203-006260	C407	C-CER,CHIP	SA
2203-006260	C408	C-CER,CHIP	SA
2203-006260	C458	C-CER,CHIP	SA
2203-006260	C460	C-CER,CHIP	SA
2203-006305	C143	C-CER,CHIP	SA
2203-006305	C15	C-CER,CHIP	SA
2203-006305	C430	C-CER,CHIP	SA
2203-006305	C431	C-CER,CHIP	SA
2203-006324	C425	C-CER,CHIP	SA
2203-006361	C100	C-CER,CHIP	SA
2203-006379	C428	C-CER,CHIP	SA
2203-006399	C148	C-CER,CHIP	SA

SEC Code	Design LOC	Discription	STATUS
2203-006399	C403	C-CER,CHIP	SA
2203-006423	C114	C-CER,CHIP	SA
2203-006423	C115	C-CER,CHIP	SA
2203-006423	C142	C-CER,CHIP	SA
2203-006423	C146	C-CER,CHIP	SA
2203-006423	C147	C-CER,CHIP	SA
2203-006423	C17	C-CER,CHIP	SA
2203-006423	C18	C-CER,CHIP	SA
2203-006423	C202	C-CER,CHIP	SA
2203-006423	C204	C-CER,CHIP	SA
2203-006423	C206	C-CER,CHIP	SA
2203-006423	C208	C-CER,CHIP	SA
2203-006423	C211	C-CER,CHIP	SA
2203-006423	C212	C-CER,CHIP	SA
2203-006423	C302	C-CER,CHIP	SA
2203-006423	C303	C-CER,CHIP	SA
2203-006423	C305	C-CER,CHIP	SA
2203-006423	C322	C-CER,CHIP	SA
2203-006423	C324	C-CER,CHIP	SA
2203-006423	C325	C-CER,CHIP	SA
2203-006423	C404	C-CER,CHIP	SA
2203-006423	C405	C-CER,CHIP	SA
2203-006423	C409	C-CER,CHIP	SA
2203-006423	C413	C-CER,CHIP	SA
2203-006423	C418	C-CER,CHIP	SA
2203-006423	C419	C-CER,CHIP	SA
2203-006423	C423	C-CER,CHIP	SA
2203-006423	C426	C-CER,CHIP	SA
2203-006423	C427	C-CER,CHIP	SA
2203-006423	C429	C-CER,CHIP	SA
2203-006423	C500	C-CER,CHIP	SA
2203-006423	C501	C-CER,CHIP	SA
2203-006423	C512	C-CER,CHIP	SA
2203-006423	C513	C-CER,CHIP	SA
2203-006423	C515	C-CER,CHIP	SA

SEC Code	Design LOC	Discription	STATUS
2203-006562	C14	C-CER,CHIP	SA
2203-006562	C149	C-CER,CHIP	SA
2203-006562	C150	C-CER,CHIP	SA
2203-006562	C310	C-CER,CHIP	SA
2203-006562	C311	C-CER,CHIP	SA
2203-006562	C312	C-CER,CHIP	SA
2203-006562	C313	C-CER,CHIP	SA
2203-006562	C314	C-CER,CHIP	SA
2203-006562	C315	C-CER,CHIP	SA
2203-006562	C316	C-CER,CHIP	SA
2203-006562	C323	C-CER,CHIP	SA
2203-006562	C329	C-CER,CHIP	SA
2203-006562	C330	C-CER,CHIP	SA
2203-006562	C331	C-CER,CHIP	SA
2203-006562	C332	C-CER,CHIP	SA
2203-006562	C333	C-CER,CHIP	SA
2203-006562	C334	C-CER,CHIP	SA
2203-006562	C335	C-CER,CHIP	SA
2203-006562	C420	C-CER,CHIP	SA
2203-006562	C422	C-CER,CHIP	SA
2203-006562	C424	C-CER,CHIP	SA
2203-006562	C432	C-CER,CHIP	SA
2203-006562	C442	C-CER,CHIP	SA
2203-006562	C443	C-CER,CHIP	SA
2203-006562	C456	C-CER,CHIP	SA
2203-006562	C457	C-CER,CHIP	SA
2203-006562	C459	C-CER,CHIP	SA
2203-006562	C463	C-CER,CHIP	SA
2203-006562	C467	C-CER,CHIP	SA
2203-006562	C502	C-CER,CHIP	SA
2203-006562	C505	C-CER,CHIP	SA
2203-006562	C511	C-CER,CHIP	SA
2203-006562	C518	C-CER,CHIP	SA
2203-006562	C519	C-CER,CHIP	SA
2203-006626	C514	C-CER,CHIP	SA

SEC Code	Design LOC	Discription	STATUS
2203-006648	C319	C-CER,CHIP	SA
2203-006648	C465	C-CER,CHIP	SA
2203-006824	C402	C-CER,CHIP	SA
2203-006824	C406	C-CER,CHIP	SA
2203-006825	C336	C-CER,CHIP	SA
2203-006825	C337	C-CER,CHIP	SA
2203-006825	C338	C-CER,CHIP	SA
2203-006825	C339	C-CER,CHIP	SA
2203-006840	C461	C-CER,CHIP	SA
2203-006840	C462	C-CER,CHIP	SA
2203-006847	C131	C-CER,CHIP	SA
2203-006847	C132	C-CER,CHIP	SA
2404-001339	TA412	C-TA,CHIP	SA
2404-001348	TA461	C-TA,CHIP	SA
2404-001348	TA462	C-TA,CHIP	SA
2404-001352	TA434	C-TA,CHIP	SA
2404-001377	TA452	C-TA,CHIP	SA
2404-001381	TA410	C-TA,CHIP	SA
2404-001394	TA503	C-TA,CHIP	SA
2404-001406	TA506	C-TA,CHIP	SA
2703-001722	L107	INDUCTOR-SMD	SA
2703-002206	L109	INDUCTOR-SMD	SA
2703-002208	L101	INDUCTOR-SMD	SA
2703-002267	L106	INDUCTOR-SMD	SA
2703-002597	L105	INDUCTOR-SMD	SA
2703-002710	L103	INDUCTOR-SMD	SA
2703-002710	L104	INDUCTOR-SMD	SA
2703-002734	L302	INDUCTOR-SMD	SA
2703-002734	L303	INDUCTOR-SMD	SA
2703-002870	L102	INDUCTOR-SMD	SA
2801-004340	OSC400	CRYSTAL-SMD	SA
2801-004373	OSC200	CRYSTAL-SMD	SA
2809-001295	TCX101	OSCILLATOR-VCTCXO	SA
2901-001256	F301	FILTER-EMI SMD	SA
2901-001324	F500	FILTER-EMI/ESD	SA

SEC Code	Design LOC	Discription	STATUS
2901-001324	F502	FILTER-EMI/ESD	SA
2901-001324	F503	FILTER-EMI/ESD	SA
2901-001324	F505	FILTER-EMI/ESD	SA
2901-001353	F501	FILTER-EMI/ESD	SA
2901-001353	F504	FILTER-EMI/ESD	SA
2911-000021	F100	DUPLEXER-FEM	SA
3301-001342	L200	BEAD-SMD	SA
3301-001342	L201	BEAD-SMD	SA
3301-001342	L400	BEAD-SMD	SA
3301-001342	L401	BEAD-SMD	SA
3301-001342	L402	BEAD-SMD	SA
3301-001342	L403	BEAD-SMD	SA
3301-001342	L404	BEAD-SMD	SA
3705-001358	RFS100	CONNECTOR-COAXIAL	SA
3709-001344	CD501	CONNECTOR-CARD EDGE	SA
3709-001355	SIM301	CONNECTOR-CARD EDGE	SA
3710-001611	IFC502	CONNECTOR-INTERFACE	SA
3711-005747	HDC503	HEADER-BOARD TO BOARD	SA
3711-005781	BTC506	CONNECTOR-BATTERY	SA
3722-002082	EAR400	JACK-PHONE	SA
4202-001072	ANT101	ANTENNA-CHIP	SA
4302-001201	BAT300	BATTERY-LI(2ND)	SA
4709-001374	MOD101	BLUETOOTH MODULE	SA
GH09-00038A	UCP201	IC MICOM	SA
GH73-05204A	QMI03	RMO-MIC HOLDER	SA

5. SGH-E770 PCB Diagrams

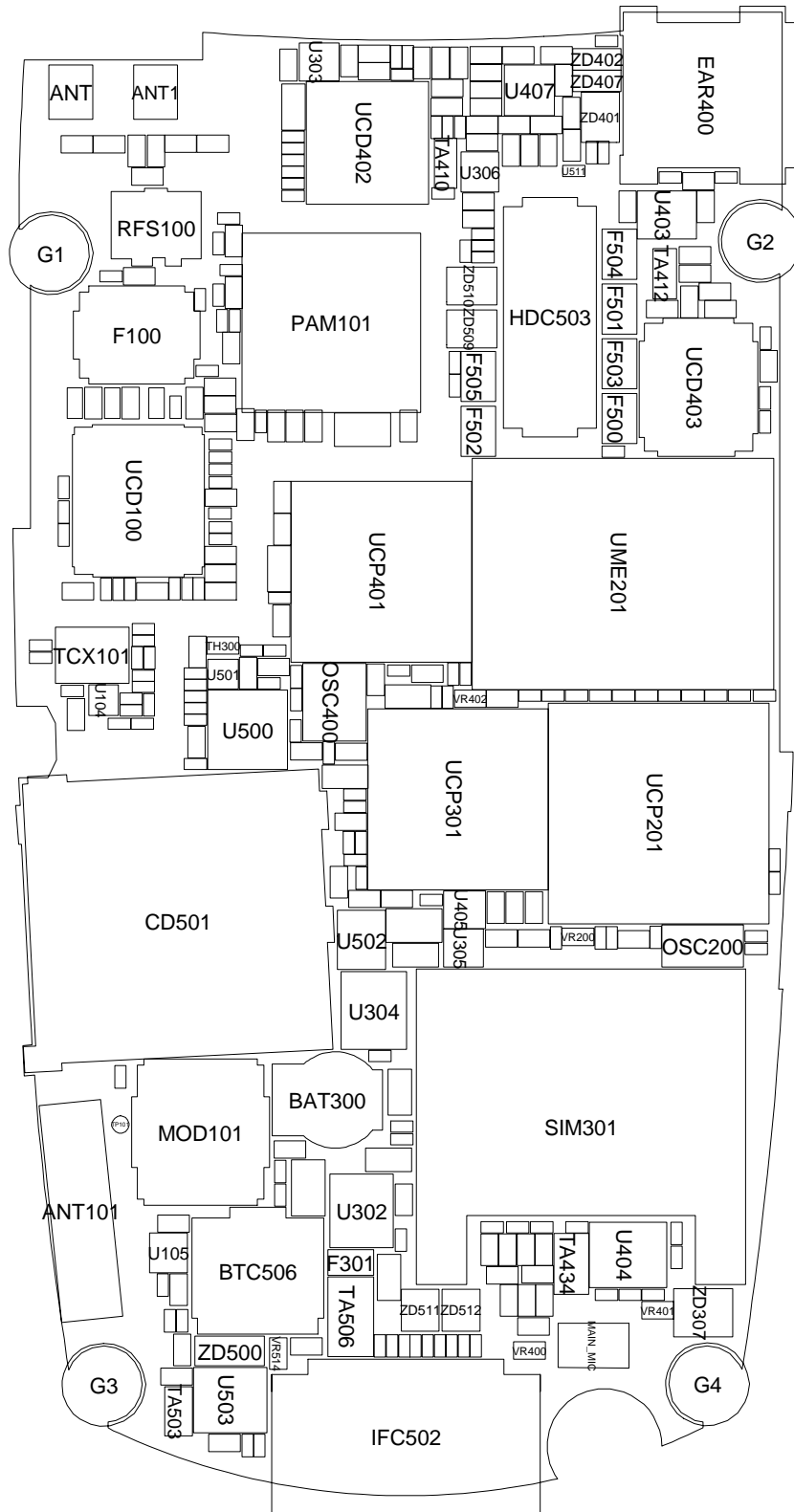

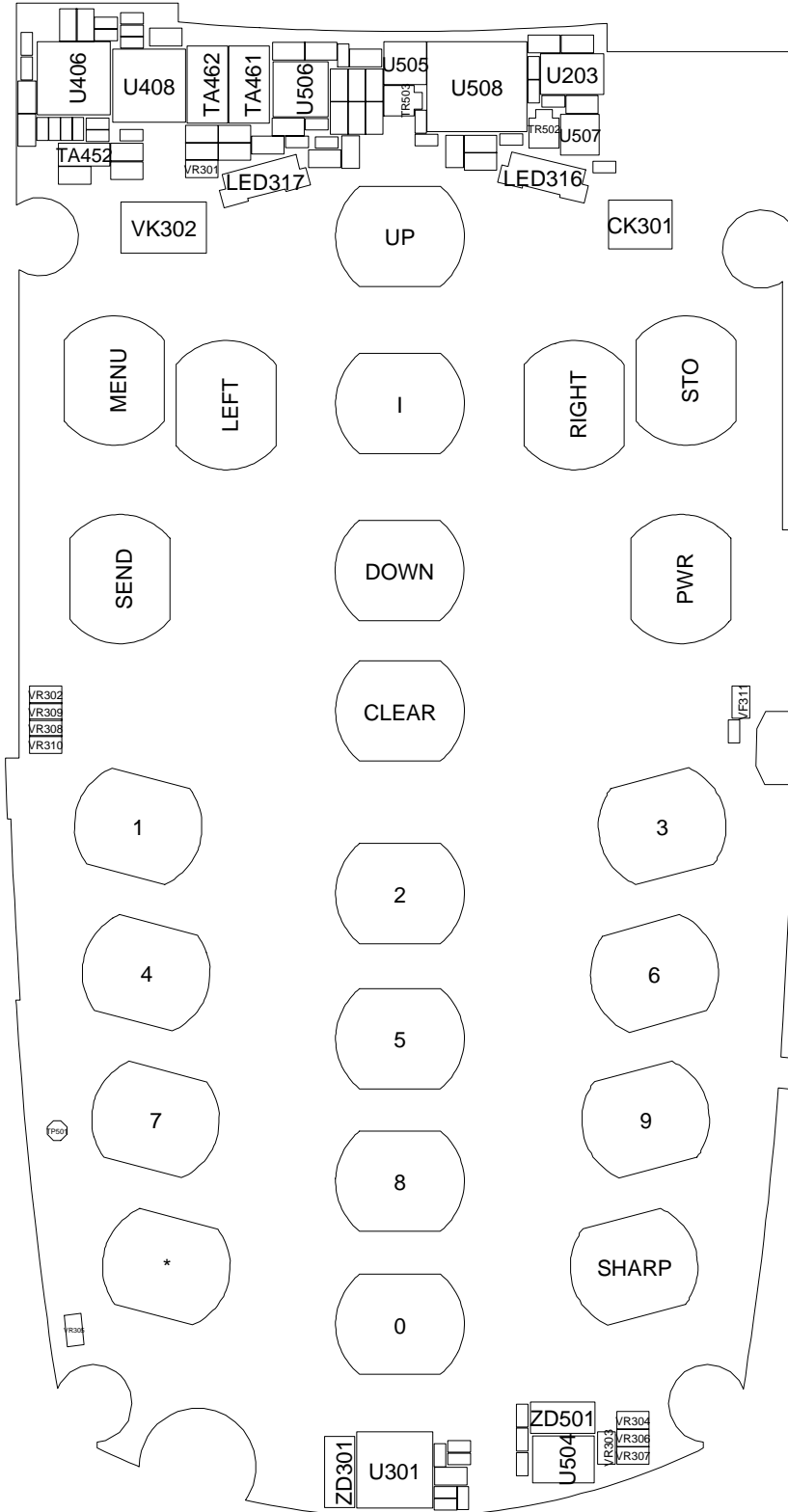

**SAMSUNG
ELECTRONICS**

