

**SAMSUNG**

# GSM TELEPHONE

## SGH-F700

# **SERVICE** *Manual*

**GSM TELEPHONE**



**CONTENTS**

1. Safety Precautions
2. Specification
3. Product Function
4. Array course control
5. Exploded View and Parts List
6. Main Electrical Parts List
7. Block Diagrams
8. PCB Diagrams
9. Flow Chart of Troubleshooting
10. Reference data
11. Disassembly and Assembly Instructions

---

# 1. Safety Precautions

---

## 1-1. Repair Precaution

- Repair in Shield Box, during detailed tuning.  
Take specially care of tuning or test,  
because specipcty of cellular phone is sensitive for surrounding interference(RF noise).
- Be careful to use a kind of magnetic object or tool,  
because performance of parts is damaged by the influence of magnetic force.
- Surely use a standard screwdriver when you disassemble this product,  
otherwise screw will be worn away.
- Use a thicken twisted wire when you measure level.  
A thicken twisted wire has low resistance, therefore error of measurement is few.
- Repair after separate Test Pack and Set because for short danger (for example an  
overcurrent and furious flames of parts etc) when you repair board in condition of  
connecting Test Pack and tuning on.
- Take specially care of soldering, because Land of PCB is small and weak in heat.
- Surely tune on/off while using AC power plug, because a repair of battery charger is  
dangerous when tuning ON/OFF PBA and Connector after disassembling charger.
- Don't use as you pleases after change other material than replacement registered on SEC System.  
Otherwise engineer in charge isn't charged with problem that you don't keep this rules.

## 1-2. ESD(Electrostatically Sensitive Devices) Precaution

Several semiconductor may be damaged easily by static electricity. Such parts are called by ESD (Electrostatically Sensitive Devices), for example IC,BGA chip etc. Read Precaution below.

You can prevent from ESD damage by static electricity.

- Remove static electricity remained your body before you touch semiconductor or parts with semiconductor. There are ways that you touch an earthed place or wear static electricity prevention string on wrist.
- Use earthed soldering steel when you connect or disconnect ESD.
- Use soldering removing tool to break static electricity. , otherwise ESD will be damaged by static electricity.
- Don't unpack until you set up ESD on product. Because most of ESD are packed by box and aluminum plate to have conductive power,they are prevented from static electricity.
- You must maintain electric contact between ESD and place due to be set up until ESD is connected completely to the proper place or a circuit board.

## 2. Specification

### 2-1. GSM General Specification

	<b>EGSM 900</b>	<b>DCS 1800</b>	<b>PCS 1900</b>	<b>WCDMA2100</b>
Freq. Band[MHz] Uplink/Downlink	880~915 925~960	1710~1785 1805~1880	1850~1910 1930~1990	1920~1980 2110~2170
ARFCN range	0~124 & 975~1023	512~885	512~810	UL:9612~9888 DL:10562~10838
Tx/Rx spacing	45MHz	95MHz	80MHz	190MHz
Mod. Bit rate/ Bit Period	270.833kbps 3.692us	270.833kbps 3.692us	270.833kbps 3.692us	3.84Mcps
Time Slot Period/Frame Period	576.9us 4.615ms	576.9us 4.615ms	576.9us 4.615ms	Frame length : 10ms Slot length: 0.667ms
Modulation	0.3GMSK	0.3GMSK	0.3GMSK	QPSK HQPSK
MS Power	33dBm~5dBm	30dBm~0dBm	30dBm~0dBm	24dBm~ -50dBm
Power Class	<sup>4</sup> (max +33dBm)	<sup>1</sup> (max +30dBm)	<sup>1</sup> (max +30dBm)	<sup>3</sup> (max +24dBm)
Sensitivity	-102dBm	-100dBm	-100dBm	-106.7dBm
TDMA Mux	8	8	8	NA
Cell Radius	35Km	2Km	2Km	2Km

## 2-2. GSM Tx Power Class

<b>TX Power control level</b>	<b>GSM900</b>	<b>TX Power control level</b>	<b>DCS1800</b>	<b>TX Power control level</b>	<b>PCS1800</b>
5	33±2 dBm	0	30±3 dBm	0	30±3 dBm
6	31±2 dBm	1	28±3 dBm	1	28±3 dBm
7	29±2 dBm	2	26±3 dBm	2	26±3 dBm
8	27±2 dBm	3	24±3 dBm	3	24±3 dBm
9	25±2 dBm	4	22±3 dBm	4	22±3 dBm
10	23±2 dBm	5	20±3 dBm	5	20±3 dBm
11	21±2 dBm	6	18±3 dBm	6	18±3 dBm
12	19±2 dBm	7	16±3 dBm	7	16±3 dBm
13	17±2 dBm	8	14±3 dBm	8	14±3 dBm
14	15±2 dBm	9	12±4 dBm	9	12±4 dBm
15	13±2 dBm	10	10±4 dBm	10	10±4 dBm
16	11±3 dBm	11	8±4dBm	11	8±4dBm
17	9±3dBm	12	6±4 dBm	12	6±4 dBm
18	7±3 dBm	13	4±4 dBm	13	4±4 dBm
19	5±3 dBm	14	2±5 dBm	14	2±5 dBm
		15	0±5 dBm	15	0±5 dBm

---

## 3. Product Function

---

### Main Function

- Full Touch Screen
- Bluetooth Class 2
- Extended GSM 900MHz & DCS1800MHz & PCS1900MHz  
&WCDMA/HSDPA2100MHz Quad Band
- Slide type
- Color LCD (262K TFD colors, 3.2", 240 x 432)
- Built-in 3Mega pixel and VGA Camera
- Built-in MP3 Player
- GPRS Multi-slot Class 12
- Downloadable Game via JAVA
- 64 Polyphonic Ring Tone
- Qwerty + 3\*4 Keypad
- Sending Photo & Video by MMS or E-Mail
- VideoTelephony
- External Memory Card Socket (T-flash)
- 1000mAh Battery



---

## 4. Array course control

---

### 4-1. Software Adjustments



1.JIG(GH80-03308A): Download, Trace, Calibration, etc

2.RF test cable(GH39-00397A): RF test

3.Test cable(SJ32-R00011): JIG to phone

1M:GH39-01010A / 1.5M:GH39-01011A / 0.6M:GH39-01012A / 0.4M:GH39-01013A

4.Travel Adaptor(GH44-01702A)

5.Data Link Cable(GH39-00922A): USB cable

6.Serial cable(LJ39-00013A) : PC to JIG

## 4-2. Software Downloading

### 4-2-1. Downloading Binary Files

- Four binary files for downloading F700V
  - amss\_compressed : Modem binary for communication function and user interface and various application
  - Rsrc\_F700\_Vodafone\_Lite.rc1: Files need for each application
  - Rsrc2\_F700V(Low).rc2 : Power on/off animation
  - FactoryFs\_F700\_Vodafone\_Lite.ffs : Default file system to be put into in initial production.

### 4-2-2. Pre-requisite for Downloading

- Downloader Program ([MultiLoader V5.30](#))
- SGH-F700V Mobile Phone
- USB Data Link Cable
- Binary files

### 4-2-3. S/W Downloader Program

1. Boot the F700V by pressing 'power ON key' + 'Fn key' at the same time.  
If you do properly, you can see the following message on Main LCD "Download"
2. Load the binary download program by executing the "**MultiLoader V5.30.exe**".  
And the Check the **MSM6245/MSM6260**

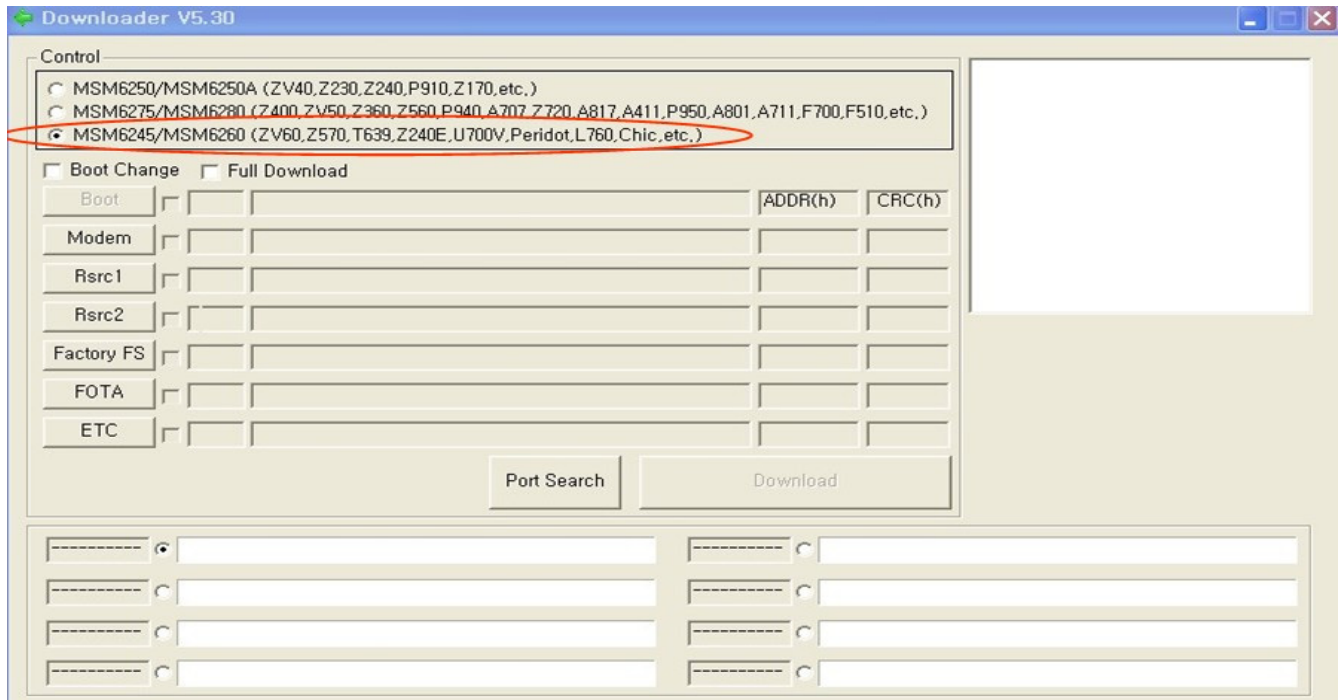

3. Select the check box what you want to download.

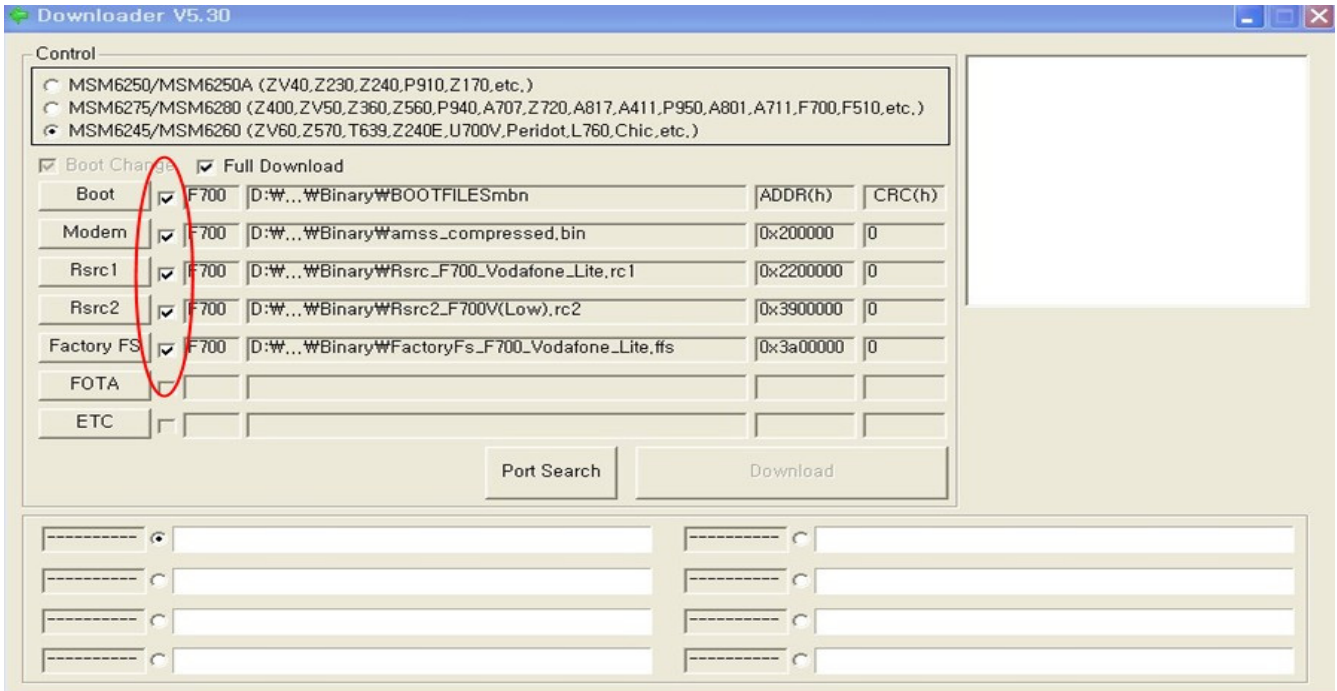

4. Select the binary file what you want to download

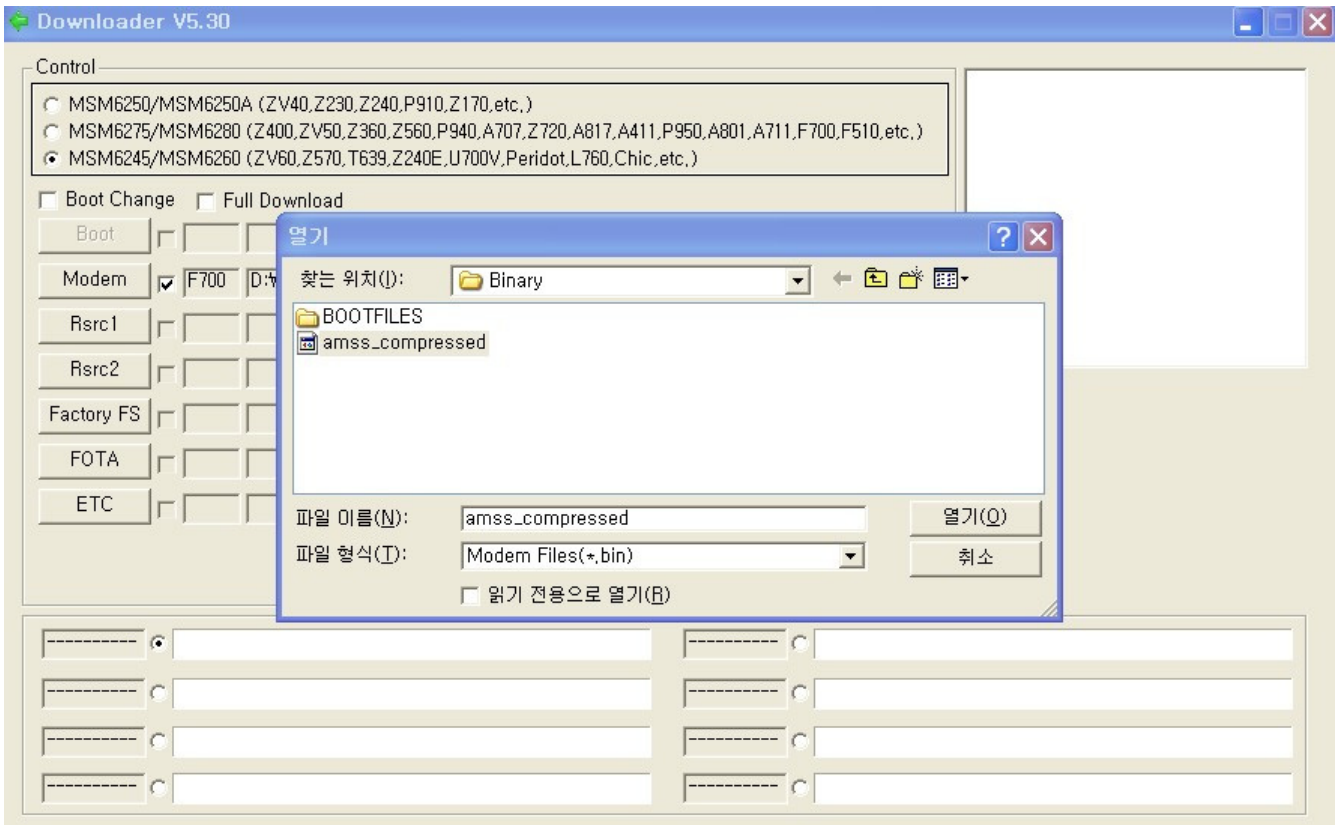

\* Up to eight ports are supported.

5. Now press the button 'DownLoad'.

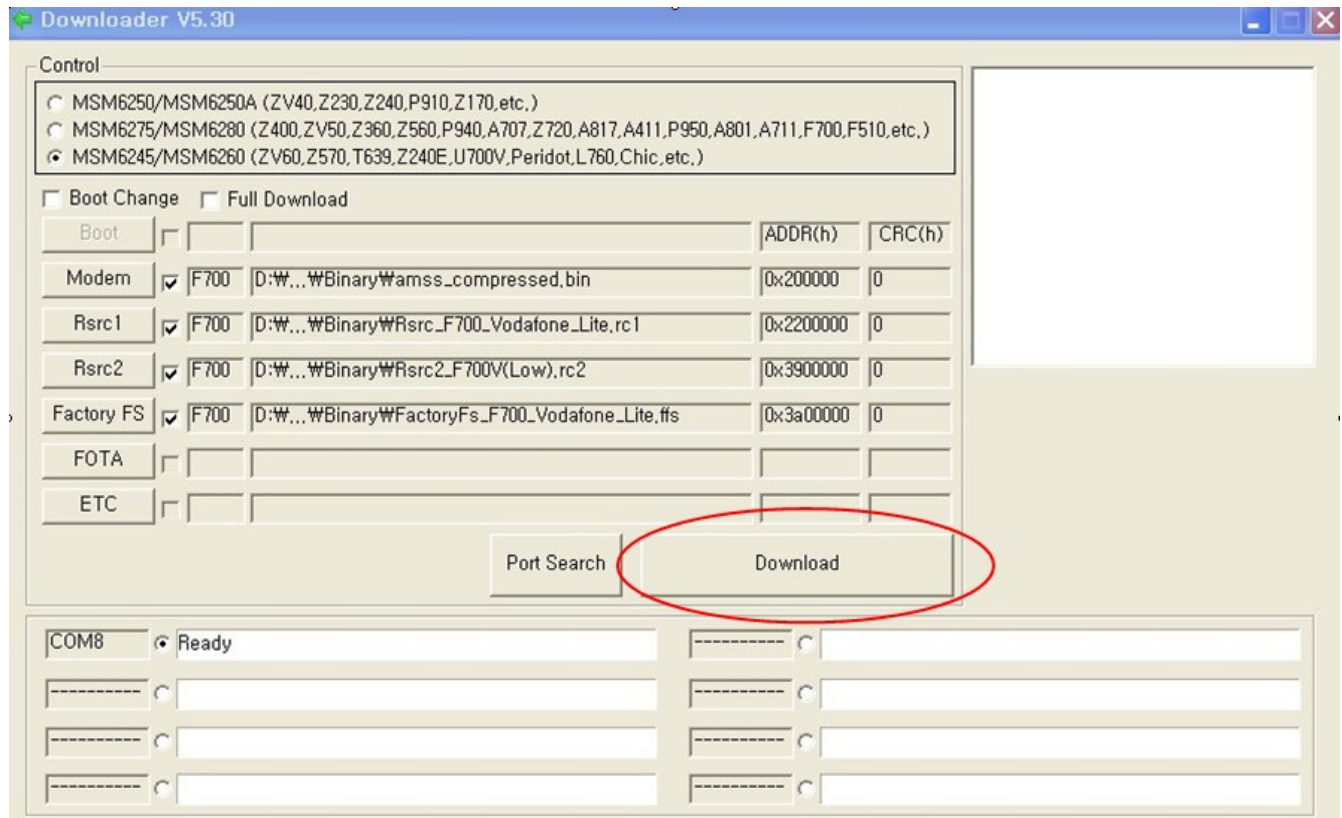

6. When downloading is complete, UE reboot automatically.

-If there is difference in FactoryFS.bin, UE will format file system automatically.





## 5-2. Cellular phone Parts List

Design LOC		Discription	SEC CODE
QAN02		INTENNA-SGHF700	GH42-01344A
QAN05		RMO RUBBER-INTENNA	GH73-11265A
QBA00		ASSY CASE-BATTERY	GH98-07075A
QBA01		INNER BATTERY PACK-1000MAH,BLK	GH43-02974A
QBA02		PMO COVER-BATTERY	GH72-45829A
QBR01		ASSY BRACKET-SHIELD	GH98-06469A
QCA01		CAMERA MODULE-3M 1/4"	GH59-04630A
QCA02		CAMERA MODULE-VGA 1/7.4"	GH59-04631A
QCA10		KEY FPCB-CAMERA KEY	GH59-04985A
QCR07		SCREW-MACHINE	6001-001691
QCR08		SCREW-MACHINE	6001-001456
QCR21		SCREW-MACHINE	6001-001507
QCR57		SCREW-MACHINE	6001-002001
QKP01		ASSY KEYPAD-(XSO/BLU)	GH98-07405A
QLC01		LCD-SGHF700	GH07-01195A
QME02		UNIT-TOUCH SCREEN (OPEN)	GH59-05299A
QMI02		MICROPHONE-ASSY-SGHF700	GH30-00426A
QMO01		MOTOR LINEAR VIBRATION-SGHF700	GH31-00380A
QMP01		PBA MAIN-SGHF700	GH92-03562A
QMP02		PBA SUB-SGHF700	GH92-03571A
QPC01		FPC-SLIDEFPCB	GH41-01884A
QRF01		TAPE-RF SHEET	GH74-35528A
QSC05		TAPE-LOWER SCREW CAP	GH74-35519A
QSH01		ICT SHIELD-A	GH70-02965A
QSH02		ICT SHIELD-B	GH70-02966A
QSP01		MICRO SPEAKER	3001-002277
QSP02		MICRO SPEAKER	3001-002278
QVK01		KEY FPCB-SIDE KEY FPCB(VK)	GH59-04983A
QVK02		KEY FPCB-SIDE KEY FPCB(PK)	GH59-04984A
QVK04		KEY FPCB-SIDE KEY FPCB(HK)	GH59-04982A

QVK08			ASSY ETC-SGH-F700 EARJACK FPCB	GH59-05012A
QVO03			PMO KEY-HOME	GH72-44223A
QME01			KEY FPCB-TF KEY	GH59-04988A
	QMI01		AS-SCHR200 MIC	GH81-06811A
QFU01			ASSY CASE-SLIDE UPPER	GH98-06213A
	QCK01		PMO KEY-CAMERA V3	GH72-43728A
	QCK02		PMO KEY-POWER V3	GH72-43726A
	QCK03		PMO KEY-HOLD V3	GH72-43725A
	QVO01		PMO KEY-VOLUME V3	GH72-43727A
QFL01			ASSY CASE-SLIDE LOWER	GH98-06217A
	QCR57		SCREW-MACHINE	6001-002001
	QCR61		SCREW-MACHINE	6001-002008
	QCR47		SCREW-MACHINE	6001-001695
	QFR01		ASSY CASE-FRONT	GH98-06214A
	QHI01		ASSY HINGE-SLIDE	GH98-06216A
		QHI18	ASSY HINGE-TORSION L	GH98-07358A
		QHI25	ASSY HINGE-TORSION R	GH98-07359A
QRE01			ASSY CASE-REAR	GH98-06215A
	QCW01		ASSY DECO-WINDOW CAMERA	GH98-06470A
	QIF01		PMO COVER-IF V4	GH72-44306A
	QRF03		PMO COVER-EAR	GH72-44269A

## 6. Main Electrical Parts List

SEC CODE	Design LOC	Discription	STATUS
0403-001547	D402	DIODE-ZENER	SA
0406-001215	D403	DIODE-TVS	SA
0406-001215	D407	DIODE-TVS	SA
0406-001231	D414	DIODE-TVS	SA
0406-001231	D415	DIODE-TVS	SA
0406-001231	D416	DIODE-TVS	SA
0406-001231	D600	DIODE-TVS	SA
0406-001231	D601	DIODE-TVS	SA
0406-001237	D400	DIODE-TVS	SNA
0406-001237	D401	DIODE-TVS	SNA
0406-001237	D406	DIODE-TVS	SNA
0406-001237	D408	DIODE-TVS	SNA
0406-001237	D412	DIODE-TVS	SNA
0406-001237	D413	DIODE-TVS	SNA
0406-001237	U102	DIODE-TVS	SNA
0406-001237	U104	DIODE-TVS	SNA
0406-001237	U201	DIODE-TVS	SNA
0406-001237	U205	DIODE-TVS	SNA
0406-001237	U206	DIODE-TVS	SNA
0406-001267	D409	DIODE-TVS	SA
0406-001267	D410	DIODE-TVS	SA
0406-001267	D411	DIODE-TVS	SA
0406-001267	D417	DIODE-TVS	SA
0406-001267	D418	DIODE-TVS	SA
0407-001002	D300	DIODE-ARRAY	SA
0504-001113	TR300	TR-DIGITAL	SA
0601-002443	L304	LED	SA
0801-002896	U106	IC-CMOS LOGIC	SA
0801-003016	U500	IC-CMOS LOGIC	SA
1001-001336	U407	IC-ANALOG SWITCH	SA
1001-001428	U200	IC-ANALOG MULTIPLEX	SA
1001-001428	U406	IC-ANALOG MULTIPLEX	SA
1001-001428	U100	IC-ANALOG MULTIPLEX	SA
1001-001436	U402	IC-ANALOG SWITCH	SA
1001-001481	U304	IC-ANALOG SWITCH	SA
1001-001481	U410	IC-ANALOG SWITCH	SA
1003-002047	U200	IC-MOTOR DRIVER	SA

Main Electrical Parts List

SEC CODE	Design LOC	Discription	STATUS
1108-000151	UME200	IC-MCP	SA
1201-002304	U101	IC-AUDIO AMP	SA
1201-002304	U105	IC-AUDIO AMP	SA
1201-002534	PAM100	IC-POWER AMP	SA
1201-002548	PAM101	IC-POWER AMP	SA
1201-002610	U608	IC-AUDIO AMP	SA
1202-001068	U409	IC-VOLTAGE COMP.	SA
1203-004339	U405	IC-MULTI REG.	SA
1203-004340	U404	IC-MULTI REG.	SA
1203-004340	U603	IC-MULTI REG.	SA
1203-004340	U202	IC-MULTI REG.	SA
1203-004358	U300	IC-DC/DC CONVERTER	SA
1203-004548	U501	IC-DC/DC CONVERTER	SA
1203-004727	U305	IC-DC/DC CONVERTER	SA
1203-004728	U606	IC-POSI.FIXED REG.	SA
1203-004728	U610	IC-POSI.FIXED REG.	SA
1203-004778	U302	IC-POWER SUPERVISOR	SA
1203-004792	U505	IC-POSI.FIXED REG.	SA
1203-004792	U203	IC-POSI.FIXED REG.	SA
1203-004793	U302	IC-POSI.FIXED REG.	SA
1203-004793	U304	IC-POSI.FIXED REG.	SA
1203-004806	U303	IC-POSI.FIXED REG.	SA
1203-004838	U303	IC-BATTERY	SA
1205-003215	UCP200	IC-MODEM	SA
1205-003228	U604	IC-CODEC	SA
1205-003297	RFT100	IC-TRANSCEIVER	SA
1205-003345	U408	IC-SWITCH	SA
1205-003349	U300	IC-SWITCH	SA
1209-001763	U301	IC-SENSOR	SA
1209-001768	C522	IC-PLL	SA
1209-001768	U204	IC-PLL	SA
1404-001224	V200	THERMISTOR-NTC	SA
2007-000138	R474	R-CHIP	SA
2007-000138	R100	R-CHIP	SA
2007-000140	R616	R-CHIP	SA
2007-000140	R619	R-CHIP	SA
2007-000144	R313	R-CHIP	SA

SEC CODE	Design LOC	Discription	STATUS
2007-000146	R309	R-CHIP	SA
2007-000148	R106	R-CHIP	SA
2007-000148	R110	R-CHIP	SA
2007-000148	R118	R-CHIP	SA
2007-000148	R121	R-CHIP	SA
2007-000148	R305	R-CHIP	SA
2007-000148	R306	R-CHIP	SA
2007-000148	R307	R-CHIP	SA
2007-000153	R319	R-CHIP	SA
2007-000153	R107	R-CHIP	SA
2007-000153	R108	R-CHIP	SA
2007-000153	R119	R-CHIP	SA
2007-000153	R120	R-CHIP	SA
2007-000157	R317	R-CHIP	SA
2007-000162	R220	R-CHIP	SA
2007-000162	R221	R-CHIP	SA
2007-000164	R214	R-CHIP	SA
2007-000165	R413	R-CHIP	SA
2007-000165	R112	R-CHIP	SA
2007-000170	R521	R-CHIP	SA
2007-000171	R100	R-CHIP	SA
2007-000171	R102	R-CHIP	SA
2007-000171	R108	R-CHIP	SA
2007-000171	R200	R-CHIP	SA
2007-000171	R204	R-CHIP	SA
2007-000171	R302	R-CHIP	SA
2007-000171	R303	R-CHIP	SA
2007-000171	R427	R-CHIP	SA
2007-000171	R428	R-CHIP	SA
2007-000171	R429	R-CHIP	SA
2007-000171	R478	R-CHIP	SA
2007-000171	R504	R-CHIP	SA
2007-000171	R508	R-CHIP	SA
2007-000171	R513	R-CHIP	SA
2007-000171	R530	R-CHIP	SA
2007-000171	R534	R-CHIP	SA
2007-000171	R540	R-CHIP	SA

Main Electrical Parts List

SEC CODE	Design LOC	Discription	STATUS
2007-000171	R636	R-CHIP	SA
2007-000171	R109	R-CHIP	SA
2007-000171	R113	R-CHIP	SA
2007-000171	R117	R-CHIP	SA
2007-000171	R200	R-CHIP	SA
2007-000171	R201	R-CHIP	SA
2007-000171	R202	R-CHIP	SA
2007-000171	R203	R-CHIP	SA
2007-000171	R204	R-CHIP	SA
2007-000171	R205	R-CHIP	SA
2007-000171	R206	R-CHIP	SA
2007-000171	R207	R-CHIP	SA
2007-000171	R208	R-CHIP	SA
2007-000171	R209	R-CHIP	SA
2007-000171	R210	R-CHIP	SA
2007-000171	R211	R-CHIP	SA
2007-000171	R212	R-CHIP	SA
2007-000171	R213	R-CHIP	SA
2007-000171	R215	R-CHIP	SA
2007-000171	R216	R-CHIP	SA
2007-000171	R217	R-CHIP	SA
2007-000171	R218	R-CHIP	SA
2007-000171	R219	R-CHIP	SA
2007-000171	R223	R-CHIP	SA
2007-000171	R224	R-CHIP	SA
2007-000171	R225	R-CHIP	SA
2007-000171	R230	R-CHIP	SA
2007-000171	R232	R-CHIP	SA
2007-000171	R300	R-CHIP	SA
2007-000171	R310	R-CHIP	SA
2007-000171	R316	R-CHIP	SA
2007-000172	R102	R-CHIP	SA
2007-000172	R103	R-CHIP	SA
2007-001119	R321	R-CHIP	SA
2007-001285	R105	R-CHIP	SA
2007-001285	R106	R-CHIP	SA
2007-001290	R209	R-CHIP	SA

SEC CODE	Design LOC	Discription	STATUS
2007-001298	R308	R-CHIP	SA
2007-001319	R617	R-CHIP	SA
2007-001319	R618	R-CHIP	SA
2007-002970	R475	R-CHIP	SA
2007-002970	R476	R-CHIP	SA
2007-002970	R644	R-CHIP	SA
2007-002970	R655	R-CHIP	SA
2007-007092	R414	R-CHIP	SA
2007-007092	R415	R-CHIP	SA
2007-007101	R304	R-CHIP	SA
2007-007135	R211	R-CHIP	SA
2007-007310	R320	R-CHIP	SA
2007-007314	R213	R-CHIP	SA
2007-007316	R322	R-CHIP	SA
2007-007318	R301	R-CHIP	SA
2007-007318	R302	R-CHIP	SA
2007-007318	R303	R-CHIP	SA
2007-007318	R311	R-CHIP	SA
2007-007318	R312	R-CHIP	SA
2007-007318	R313	R-CHIP	SA
2007-007318	R314	R-CHIP	SA
2007-007468	R305	R-CHIP	SA
2007-007741	R440	R-CHIP	SA
2007-007766	R323	R-CHIP	SA
2007-008043	R114	R-CHIP	SA
2007-008043	R115	R-CHIP	SA
2007-008044	R113	R-CHIP	SA
2007-008045	R116	R-CHIP	SA
2007-008045	R117	R-CHIP	SA
2007-008045	R118	R-CHIP	SA
2007-008045	R219	R-CHIP	SA
2007-008045	R330	R-CHIP	SA
2007-008045	R469	R-CHIP	SA
2007-008045	R470	R-CHIP	SA
2007-008046	R112	R-CHIP	SA
2007-008049	R205	R-CHIP	SA
2007-008052	R212	R-CHIP	SA

Main Electrical Parts List

SEC CODE	Design LOC	Discription	STATUS
2007-008055	R121	R-CHIP	SA
2007-008055	R324	R-CHIP	SA
2007-008055	R325	R-CHIP	SA
2007-008055	R326	R-CHIP	SA
2007-008055	R442	R-CHIP	SA
2007-008055	R453	R-CHIP	SA
2007-008055	R511	R-CHIP	SA
2007-008055	R515	R-CHIP	SA
2007-008057	R109	R-CHIP	SA
2007-008057	R110	R-CHIP	SA
2007-008419	R104	R-CHIP	SA
2007-008419	R462	R-CHIP	SA
2007-008419	R463	R-CHIP	SA
2007-008419	R464	R-CHIP	SA
2007-008419	R465	R-CHIP	SA
2007-008419	R623	R-CHIP	SA
2007-008419	R624	R-CHIP	SA
2007-008419	R629	R-CHIP	SA
2007-008419	R630	R-CHIP	SA
2007-008483	R314	R-CHIP	SA
2007-008483	R443	R-CHIP	SA
2007-008483	R444	R-CHIP	SA
2007-008483	R445	R-CHIP	SA
2007-008483	R446	R-CHIP	SA
2007-008483	R447	R-CHIP	SA
2007-008483	R451	R-CHIP	SA
2007-008486	R315	R-CHIP	SA
2007-008486	R316	R-CHIP	SA
2007-008486	R641	R-CHIP	SA
2007-008516	R201	R-CHIP	SA
2007-008516	R202	R-CHIP	SA
2007-008516	R208	R-CHIP	SA
2007-008516	R312	R-CHIP	SA
2007-008516	R448	R-CHIP	SA
2007-008516	R471	R-CHIP	SA
2007-008542	R203	R-CHIP	SA
2007-008542	R216	R-CHIP	SA

SEC CODE	Design LOC	Discription	STATUS
2007-008542	R300	R-CHIP	SA
2007-008542	R301	R-CHIP	SA
2007-008542	R310	R-CHIP	SA
2007-008542	R311	R-CHIP	SA
2007-008542	R317	R-CHIP	SA
2007-008542	R318	R-CHIP	SA
2007-008542	R331	R-CHIP	SA
2007-008542	R332	R-CHIP	SA
2007-008542	R333	R-CHIP	SA
2007-008542	R405	R-CHIP	SA
2007-008542	R406	R-CHIP	SA
2007-008542	R408	R-CHIP	SA
2007-008542	R410	R-CHIP	SA
2007-008542	R418	R-CHIP	SA
2007-008542	R419	R-CHIP	SA
2007-008542	R433	R-CHIP	SA
2007-008542	R434	R-CHIP	SA
2007-008542	R435	R-CHIP	SA
2007-008542	R437	R-CHIP	SA
2007-008542	R438	R-CHIP	SA
2007-008542	R461	R-CHIP	SA
2007-008542	R466	R-CHIP	SA
2007-008542	R472	R-CHIP	SA
2007-008542	R473	R-CHIP	SA
2007-008542	R512	R-CHIP	SA
2007-008542	R519	R-CHIP	SA
2007-008542	R520	R-CHIP	SA
2007-008542	R526	R-CHIP	SA
2007-008542	R528	R-CHIP	SA
2007-008542	R529	R-CHIP	SA
2007-008542	R533	R-CHIP	SA
2007-008542	R535	R-CHIP	SA
2007-008542	R537	R-CHIP	SA
2007-008542	R538	R-CHIP	SA
2007-008542	R606	R-CHIP	SA
2007-008542	R631	R-CHIP	SA
2007-008542	R632	R-CHIP	SA

Main Electrical Parts List

SEC CODE	Design LOC	Discription	STATUS
2007-008542	R633	R-CHIP	SA
2007-008542	R634	R-CHIP	SA
2007-008542	R642	R-CHIP	SA
2007-008542	R643	R-CHIP	SA
2007-008548	R412	R-CHIP	SA
2007-008548	R625	R-CHIP	SA
2007-008548	R626	R-CHIP	SA
2007-008548	R627	R-CHIP	SA
2007-008548	R628	R-CHIP	SA
2007-008588	R111	R-CHIP	SA
2007-008588	R217	R-CHIP	SA
2007-008588	R218	R-CHIP	SA
2007-008588	R450	R-CHIP	SA
2007-008588	R452	R-CHIP	SA
2007-008588	R604	R-CHIP	SA
2007-008588	R605	R-CHIP	SA
2007-008806	R119	R-CHIP	SA
2007-008806	R120	R-CHIP	SA
2007-008806	R215	R-CHIP	SA
2007-008806	R308	R-CHIP	SA
2007-009084	R214	R-CHIP	SA
2007-009084	R402	R-CHIP	SA
2007-009084	R409	R-CHIP	SA
2007-009111	R416	R-CHIP	SA
2007-009157	R503	R-CHIP	SA
2007-009170	R220	R-CHIP	SA
2007-009170	R223	R-CHIP	SA
2007-009170	R400	R-CHIP	SA
2007-009170	R404	R-CHIP	SA
2007-009170	R411	R-CHIP	SA
2007-009171	R307	R-CHIP	SA
2007-009171	R309	R-CHIP	SA
2007-009171	R458	R-CHIP	SA
2007-009171	R459	R-CHIP	SA
2007-009171	R460	R-CHIP	SA
2007-009199	R107	R-CHIP	SA
2007-009212	R210	R-CHIP	SA

SEC CODE	Design LOC	Discription	STATUS
2007-009233	R401	R-CHIP	SA
2007-009233	R403	R-CHIP	SA
2007-009402	R439	R-CHIP	SA
2007-009402	R441	R-CHIP	SA
2007-009420	R103	R-CHIP	SA
2007-009801	R506	R-CHIP	SA
2007-009810	R517	R-CHIP	SA
2203-000233	C163	C-CER,CHIP	SA
2203-000233	C172	C-CER,CHIP	SA
2203-000233	C328	C-CER,CHIP	SA
2203-000233	C332	C-CER,CHIP	SA
2203-000233	C677	C-CER,CHIP	SA
2203-000254	C230	C-CER,CHIP	SA
2203-000254	C306	C-CER,CHIP	SA
2203-000278	C214	C-CER,CHIP	SA
2203-000278	C217	C-CER,CHIP	SA
2203-000278	C524	C-CER,CHIP	SA
2203-000278	C525	C-CER,CHIP	SA
2203-000278	C217	C-CER,CHIP	SA
2203-000330	C187	C-CER,CHIP	SA
2203-000330	C326	C-CER,CHIP	SA
2203-000386	C313	C-CER,CHIP	SA
2203-000386	C220	C-CER,CHIP	SA
2203-000386	C222	C-CER,CHIP	SA
2203-000438	C102	C-CER,CHIP	SA
2203-000438	C109	C-CER,CHIP	SA
2203-000438	C116	C-CER,CHIP	SA
2203-000438	C119	C-CER,CHIP	SA
2203-000725	C201	C-CER,CHIP	SA
2203-000812	C194	C-CER,CHIP	SA
2203-000812	C195	C-CER,CHIP	SA
2203-000812	C197	C-CER,CHIP	SA
2203-000812	C400	C-CER,CHIP	SA
2203-000812	C405	C-CER,CHIP	SA
2203-000812	C425	C-CER,CHIP	SA
2203-000812	C426	C-CER,CHIP	SA
2203-000812	C204	C-CER,CHIP	SA

Main Electrical Parts List

SEC CODE	Design LOC	Discription	STATUS
2203-000812	C205	C-CER,CHIP	SA
2203-000812	C208	C-CER,CHIP	SA
2203-000812	C218	C-CER,CHIP	SA
2203-000812	C233	C-CER,CHIP	SA
2203-000812	C314	C-CER,CHIP	SA
2203-000812	C315	C-CER,CHIP	SA
2203-000854	C627	C-CER,CHIP	SA
2203-000854	C100	C-CER,CHIP	SA
2203-000854	C101	C-CER,CHIP	SA
2203-000854	C106	C-CER,CHIP	SA
2203-000854	C108	C-CER,CHIP	SA
2203-000854	C110	C-CER,CHIP	SA
2203-000854	C112	C-CER,CHIP	SA
2203-000854	C114	C-CER,CHIP	SA
2203-000854	C115	C-CER,CHIP	SA
2203-000854	C211	C-CER,CHIP	SA
2203-000854	C214	C-CER,CHIP	SA
2203-000854	C215	C-CER,CHIP	SA
2203-000854	C216	C-CER,CHIP	SA
2203-000854	C223	C-CER,CHIP	SA
2203-000854	C224	C-CER,CHIP	SA
2203-002668	C117	C-CER,CHIP	SA
2203-002668	C124	C-CER,CHIP	SA
2203-002677	C713	C-CER,CHIP	SA
2203-003054	C667	C-CER,CHIP	SA
2203-003054	C105	C-CER,CHIP	SA
2203-003054	C113	C-CER,CHIP	SA
2203-003054	C210	C-CER,CHIP	SA
2203-003054	C213	C-CER,CHIP	SA
2203-003054	C219	C-CER,CHIP	SA
2203-003054	C221	C-CER,CHIP	SA
2203-005249	C311	C-CER,CHIP	SA
2203-005383	C196	C-CER,CHIP	SA
2203-005446	C182	C-CER,CHIP	SA
2203-005482	C218	C-CER,CHIP	SA
2203-005482	C629	C-CER,CHIP	SA
2203-005482	C635	C-CER,CHIP	SA

SEC CODE	Design LOC	Discription	STATUS
2203-005482	C206	C-CER,CHIP	SA
2203-005482	C207	C-CER,CHIP	SA
2203-005482	C209	C-CER,CHIP	SA
2203-005482	C212	C-CER,CHIP	SA
2203-005482	C231	C-CER,CHIP	SA
2203-005482	C232	C-CER,CHIP	SA
2203-005482	C313	C-CER,CHIP	SA
2203-005482	C316	C-CER,CHIP	SA
2203-005496	C184	C-CER,CHIP	SA
2203-005682	C104	C-CER,CHIP	SA
2203-005682	C106	C-CER,CHIP	SA
2203-005682	C121	C-CER,CHIP	SA
2203-005682	C122	C-CER,CHIP	SA
2203-005682	C123	C-CER,CHIP	SA
2203-005682	C135	C-CER,CHIP	SA
2203-005682	C139	C-CER,CHIP	SA
2203-005682	C140	C-CER,CHIP	SA
2203-005682	C152	C-CER,CHIP	SA
2203-005682	C161	C-CER,CHIP	SA
2203-005682	C162	C-CER,CHIP	SA
2203-005682	C203	C-CER,CHIP	SA
2203-005682	C208	C-CER,CHIP	SA
2203-005682	C222	C-CER,CHIP	SA
2203-005682	C231	C-CER,CHIP	SA
2203-005682	C236	C-CER,CHIP	SA
2203-005682	C242	C-CER,CHIP	SA
2203-005682	C247	C-CER,CHIP	SA
2203-005682	C259	C-CER,CHIP	SA
2203-005682	C330	C-CER,CHIP	SA
2203-005682	C403	C-CER,CHIP	SA
2203-005682	C409	C-CER,CHIP	SA
2203-005682	C411	C-CER,CHIP	SA
2203-005682	C413	C-CER,CHIP	SA
2203-005682	C415	C-CER,CHIP	SA
2203-005682	C416	C-CER,CHIP	SA
2203-005682	C417	C-CER,CHIP	SA
2203-005682	C418	C-CER,CHIP	SA

Main Electrical Parts List

SEC CODE	Design LOC	Discription	STATUS
2203-005682	C419	C-CER,CHIP	SA
2203-005682	C422	C-CER,CHIP	SA
2203-005682	C428	C-CER,CHIP	SA
2203-005682	C429	C-CER,CHIP	SA
2203-005682	C434	C-CER,CHIP	SA
2203-005682	C436	C-CER,CHIP	SA
2203-005682	C437	C-CER,CHIP	SA
2203-005682	C438	C-CER,CHIP	SA
2203-005682	C445	C-CER,CHIP	SA
2203-005682	C446	C-CER,CHIP	SA
2203-005682	C447	C-CER,CHIP	SA
2203-005682	C448	C-CER,CHIP	SA
2203-005682	C449	C-CER,CHIP	SA
2203-005682	C450	C-CER,CHIP	SA
2203-005682	C451	C-CER,CHIP	SA
2203-005682	C453	C-CER,CHIP	SA
2203-005682	C454	C-CER,CHIP	SA
2203-005682	C455	C-CER,CHIP	SA
2203-005682	C469	C-CER,CHIP	SA
2203-005682	C470	C-CER,CHIP	SA
2203-005682	C471	C-CER,CHIP	SA
2203-005682	C472	C-CER,CHIP	SA
2203-005682	C473	C-CER,CHIP	SA
2203-005682	C476	C-CER,CHIP	SA
2203-005682	C477	C-CER,CHIP	SA
2203-005682	C478	C-CER,CHIP	SA
2203-005682	C479	C-CER,CHIP	SA
2203-005682	C480	C-CER,CHIP	SA
2203-005682	C481	C-CER,CHIP	SA
2203-005682	C482	C-CER,CHIP	SA
2203-005682	C483	C-CER,CHIP	SA
2203-005682	C484	C-CER,CHIP	SA
2203-005682	C485	C-CER,CHIP	SA
2203-005682	C486	C-CER,CHIP	SA
2203-005682	C488	C-CER,CHIP	SA
2203-005682	C490	C-CER,CHIP	SA
2203-005682	C495	C-CER,CHIP	SA

SEC CODE	Design LOC	Discription	STATUS
2203-005682	C496	C-CER,CHIP	SA
2203-005682	C497	C-CER,CHIP	SA
2203-005682	C498	C-CER,CHIP	SA
2203-005682	C499	C-CER,CHIP	SA
2203-005682	C707	C-CER,CHIP	SA
2203-005682	C711	C-CER,CHIP	SA
2203-005682	C712	C-CER,CHIP	SA
2203-005682	U612	C-CER,CHIP	SA
2203-005719	C186	C-CER,CHIP	SA
2203-005719	C213	C-CER,CHIP	SA
2203-005719	C215	C-CER,CHIP	SA
2203-005719	C216	C-CER,CHIP	SA
2203-005719	C219	C-CER,CHIP	SA
2203-005719	C401	C-CER,CHIP	SA
2203-005719	C402	C-CER,CHIP	SA
2203-005719	C611	C-CER,CHIP	SA
2203-005719	C616	C-CER,CHIP	SA
2203-005719	C656	C-CER,CHIP	SA
2203-005719	C657	C-CER,CHIP	SA
2203-005719	C658	C-CER,CHIP	SA
2203-005719	C659	C-CER,CHIP	SA
2203-005719	C674	C-CER,CHIP	SA
2203-005719	C675	C-CER,CHIP	SA
2203-005725	C118	C-CER,CHIP	SA
2203-005725	C125	C-CER,CHIP	SA
2203-005725	C132	C-CER,CHIP	SA
2203-005725	C136	C-CER,CHIP	SA
2203-005725	C142	C-CER,CHIP	SA
2203-005725	C144	C-CER,CHIP	SA
2203-005725	C151	C-CER,CHIP	SA
2203-005725	C153	C-CER,CHIP	SA
2203-005725	C154	C-CER,CHIP	SA
2203-005725	C155	C-CER,CHIP	SA
2203-005725	C158	C-CER,CHIP	SA
2203-005725	C159	C-CER,CHIP	SA
2203-005725	C166	C-CER,CHIP	SA
2203-005725	C173	C-CER,CHIP	SA

Main Electrical Parts List

SEC CODE	Design LOC	Discription	STATUS
2203-005725	C174	C-CER,CHIP	SA
2203-005725	C175	C-CER,CHIP	SA
2203-005725	C179	C-CER,CHIP	SA
2203-005727	C183	C-CER,CHIP	SA
2203-005727	C193	C-CER,CHIP	SA
2203-005729	C666	C-CER,CHIP	SA
2203-005732	C100	C-CER,CHIP	SA
2203-005732	C101	C-CER,CHIP	SA
2203-005736	C109	C-CER,CHIP	SA
2203-005736	C110	C-CER,CHIP	SA
2203-005736	C111	C-CER,CHIP	SA
2203-005736	C120	C-CER,CHIP	SA
2203-005736	C129	C-CER,CHIP	SA
2203-005736	C143	C-CER,CHIP	SA
2203-005736	C157	C-CER,CHIP	SA
2203-005736	C167	C-CER,CHIP	SA
2203-005736	C169	C-CER,CHIP	SA
2203-005736	C180	C-CER,CHIP	SA
2203-005736	C191	C-CER,CHIP	SA
2203-005736	C221	C-CER,CHIP	SA
2203-005736	C327	C-CER,CHIP	SA
2203-005736	C329	C-CER,CHIP	SA
2203-005736	C337	C-CER,CHIP	SA
2203-005736	C683	C-CER,CHIP	SA
2203-005736	C708	C-CER,CHIP	SA
2203-005736	C709	C-CER,CHIP	SA
2203-005736	C710	C-CER,CHIP	SA
2203-005779	C605	C-CER,CHIP	SA
2203-005779	C609	C-CER,CHIP	SA
2203-005792	C108	C-CER,CHIP	SA
2203-005806	C148	C-CER,CHIP	SNA
2203-005806	C150	C-CER,CHIP	SNA
2203-005806	C198	C-CER,CHIP	SNA
2203-005806	C204	C-CER,CHIP	SNA
2203-005806	C223	C-CER,CHIP	SNA
2203-005806	C224	C-CER,CHIP	SNA
2203-005806	C232	C-CER,CHIP	SNA

SEC CODE	Design LOC	Discription	STATUS
2203-005806	C233	C-CER,CHIP	SNA
2203-005806	C238	C-CER,CHIP	SNA
2203-005806	C239	C-CER,CHIP	SNA
2203-005806	C706	C-CER,CHIP	SNA
2203-006047	C210	C-CER,CHIP	SA
2203-006048	C406	C-CER,CHIP	SA
2203-006048	C423	C-CER,CHIP	SA
2203-006048	C302	C-CER,CHIP	SA
2203-006048	C303	C-CER,CHIP	SA
2203-006048	C304	C-CER,CHIP	SA
2203-006048	C308	C-CER,CHIP	SA
2203-006048	C309	C-CER,CHIP	SA
2203-006048	C310	C-CER,CHIP	SA
2203-006048	C312	C-CER,CHIP	SA
2203-006120	C192	C-CER,CHIP	SA
2203-006123	C119	C-CER,CHIP	SA
2203-006123	C128	C-CER,CHIP	SA
2203-006194	C202	C-CER,CHIP	SA
2203-006194	C205	C-CER,CHIP	SA
2203-006194	C225	C-CER,CHIP	SA
2203-006194	C226	C-CER,CHIP	SA
2203-006194	C227	C-CER,CHIP	SA
2203-006194	C228	C-CER,CHIP	SA
2203-006194	C235	C-CER,CHIP	SA
2203-006194	C240	C-CER,CHIP	SA
2203-006194	C241	C-CER,CHIP	SA
2203-006194	C243	C-CER,CHIP	SA
2203-006194	C244	C-CER,CHIP	SA
2203-006194	C245	C-CER,CHIP	SA
2203-006194	C246	C-CER,CHIP	SA
2203-006194	C252	C-CER,CHIP	SA
2203-006194	C253	C-CER,CHIP	SA
2203-006194	C254	C-CER,CHIP	SA
2203-006194	C702	C-CER,CHIP	SA
2203-006194	C703	C-CER,CHIP	SA
2203-006194	C705	C-CER,CHIP	SA
2203-006208	C515	C-CER,CHIP	SA

Main Electrical Parts List

SEC CODE	Design LOC	Discription	STATUS
2203-006257	C610	C-CER,CHIP	SA
2203-006257	C613	C-CER,CHIP	SA
2203-006257	C621	C-CER,CHIP	SA
2203-006257	C622	C-CER,CHIP	SA
2203-006257	C687	C-CER,CHIP	SA
2203-006257	C689	C-CER,CHIP	SA
2203-006305	C404	C-CER,CHIP	SA
2203-006305	C440	C-CER,CHIP	SA
2203-006305	C615	C-CER,CHIP	SA
2203-006307	C342	C-CER,CHIP	SA
2203-006324	C188	C-CER,CHIP	SA
2203-006324	C190	C-CER,CHIP	SA
2203-006324	C305	C-CER,CHIP	SA
2203-006324	C336	C-CER,CHIP	SA
2203-006324	C516	C-CER,CHIP	SA
2203-006348	C335	C-CER,CHIP	SA
2203-006361	C333	C-CER,CHIP	SA
2203-006361	C334	C-CER,CHIP	SA
2203-006361	C305	C-CER,CHIP	SA
2203-006361	C307	C-CER,CHIP	SA
2203-006399	C323	C-CER,CHIP	SA
2203-006399	C325	C-CER,CHIP	SA
2203-006423	C105	C-CER,CHIP	SA
2203-006423	C112	C-CER,CHIP	SA
2203-006423	C113	C-CER,CHIP	SA
2203-006423	C114	C-CER,CHIP	SA
2203-006423	C115	C-CER,CHIP	SA
2203-006423	C126	C-CER,CHIP	SA
2203-006423	C130	C-CER,CHIP	SA
2203-006423	C133	C-CER,CHIP	SA
2203-006423	C145	C-CER,CHIP	SA
2203-006423	C146	C-CER,CHIP	SA
2203-006423	C147	C-CER,CHIP	SA
2203-006423	C149	C-CER,CHIP	SA
2203-006423	C156	C-CER,CHIP	SA
2203-006423	C160	C-CER,CHIP	SA
2203-006423	C164	C-CER,CHIP	SA

SEC CODE	Design LOC	Discription	STATUS
2203-006423	C165	C-CER,CHIP	SA
2203-006423	C168	C-CER,CHIP	SA
2203-006423	C176	C-CER,CHIP	SA
2203-006423	C178	C-CER,CHIP	SA
2203-006423	C201	C-CER,CHIP	SA
2203-006423	C206	C-CER,CHIP	SA
2203-006423	C207	C-CER,CHIP	SA
2203-006423	C211	C-CER,CHIP	SA
2203-006423	C212	C-CER,CHIP	SA
2203-006423	C220	C-CER,CHIP	SA
2203-006423	C237	C-CER,CHIP	SA
2203-006423	C248	C-CER,CHIP	SA
2203-006423	C249	C-CER,CHIP	SA
2203-006423	C250	C-CER,CHIP	SA
2203-006423	C251	C-CER,CHIP	SA
2203-006423	C255	C-CER,CHIP	SA
2203-006423	C256	C-CER,CHIP	SA
2203-006423	C257	C-CER,CHIP	SA
2203-006423	C260	C-CER,CHIP	SA
2203-006423	C261	C-CER,CHIP	SA
2203-006423	C262	C-CER,CHIP	SA
2203-006423	C263	C-CER,CHIP	SA
2203-006423	C264	C-CER,CHIP	SA
2203-006423	C267	C-CER,CHIP	SA
2203-006423	C312	C-CER,CHIP	SA
2203-006423	C345	C-CER,CHIP	SA
2203-006423	C431	C-CER,CHIP	SA
2203-006423	C432	C-CER,CHIP	SA
2203-006423	C433	C-CER,CHIP	SA
2203-006423	C439	C-CER,CHIP	SA
2203-006423	C444	C-CER,CHIP	SA
2203-006423	C452	C-CER,CHIP	SA
2203-006423	C466	C-CER,CHIP	SA
2203-006423	C500	C-CER,CHIP	SA
2203-006423	C501	C-CER,CHIP	SA
2203-006423	C502	C-CER,CHIP	SA
2203-006423	C503	C-CER,CHIP	SA

Main Electrical Parts List

SEC CODE	Design LOC	Discription	STATUS
2203-006423	C504	C-CER,CHIP	SA
2203-006423	C505	C-CER,CHIP	SA
2203-006423	C506	C-CER,CHIP	SA
2203-006423	C507	C-CER,CHIP	SA
2203-006423	C508	C-CER,CHIP	SA
2203-006423	C510	C-CER,CHIP	SA
2203-006423	C511	C-CER,CHIP	SA
2203-006423	C512	C-CER,CHIP	SA
2203-006423	C513	C-CER,CHIP	SA
2203-006423	C514	C-CER,CHIP	SA
2203-006423	C517	C-CER,CHIP	SA
2203-006423	C521	C-CER,CHIP	SA
2203-006423	C531	C-CER,CHIP	SA
2203-006423	C532	C-CER,CHIP	SA
2203-006423	C600	C-CER,CHIP	SA
2203-006423	C601	C-CER,CHIP	SA
2203-006423	C639	C-CER,CHIP	SA
2203-006423	C655	C-CER,CHIP	SA
2203-006423	C663	C-CER,CHIP	SA
2203-006423	C664	C-CER,CHIP	SA
2203-006423	C669	C-CER,CHIP	SA
2203-006423	C670	C-CER,CHIP	SA
2203-006423	C672	C-CER,CHIP	SA
2203-006423	C680	C-CER,CHIP	SA
2203-006423	C684	C-CER,CHIP	SA
2203-006423	C685	C-CER,CHIP	SA
2203-006423	C704	C-CER,CHIP	SA
2203-006556	C266	C-CER,CHIP	SA
2203-006562	C265	C-CER,CHIP	SA
2203-006562	C421	C-CER,CHIP	SA
2203-006562	C441	C-CER,CHIP	SA
2203-006562	C442	C-CER,CHIP	SA
2203-006562	C443	C-CER,CHIP	SA
2203-006562	C456	C-CER,CHIP	SA
2203-006562	C457	C-CER,CHIP	SA
2203-006562	C458	C-CER,CHIP	SA
2203-006562	C518	C-CER,CHIP	SA

SEC CODE	Design LOC	Discription	STATUS
2203-006562	C519	C-CER,CHIP	SA
2203-006562	C604	C-CER,CHIP	SA
2203-006562	C623	C-CER,CHIP	SA
2203-006562	C624	C-CER,CHIP	SA
2203-006562	C625	C-CER,CHIP	SA
2203-006562	C638	C-CER,CHIP	SA
2203-006562	C640	C-CER,CHIP	SA
2203-006562	C671	C-CER,CHIP	SA
2203-006562	C673	C-CER,CHIP	SA
2203-006562	C678	C-CER,CHIP	SA
2203-006562	C679	C-CER,CHIP	SA
2203-006562	C682	C-CER,CHIP	SA
2203-006562	C686	C-CER,CHIP	SA
2203-006562	C688	C-CER,CHIP	SA
2203-006562	C103	C-CER,CHIP	SA
2203-006562	C200	C-CER,CHIP	SA
2203-006562	C225	C-CER,CHIP	SA
2203-006562	C226	C-CER,CHIP	SA
2203-006562	C227	C-CER,CHIP	SA
2203-006562	C228	C-CER,CHIP	SA
2203-006562	C229	C-CER,CHIP	SA
2203-006562	C300	C-CER,CHIP	SA
2203-006562	C301	C-CER,CHIP	SA
2203-006562	C317	C-CER,CHIP	SA
2203-006562	C318	C-CER,CHIP	SA
2203-006562	C319	C-CER,CHIP	SA
2203-006562	C320	C-CER,CHIP	SA
2203-006562	C321	C-CER,CHIP	SA
2203-006562	C322	C-CER,CHIP	SA
2203-006585	C104	C-CER,CHIP	SA
2203-006585	C107	C-CER,CHIP	SA
2203-006585	C117	C-CER,CHIP	SA
2203-006585	C118	C-CER,CHIP	SA
2203-006648	C181	C-CER,CHIP	SA
2203-006665	C134	C-CER,CHIP	SA
2203-006665	C137	C-CER,CHIP	SA
2203-006668	C200	C-CER,CHIP	SA

Main Electrical Parts List

SEC CODE	Design LOC	Discription	STATUS
2203-006824	C170	C-CER,CHIP	SA
2203-006824	C171	C-CER,CHIP	SA
2203-006824	C300	C-CER,CHIP	SA
2203-006824	C301	C-CER,CHIP	SA
2203-006824	C302	C-CER,CHIP	SA
2203-006824	C303	C-CER,CHIP	SA
2203-006824	C318	C-CER,CHIP	SA
2203-006824	C319	C-CER,CHIP	SA
2203-006824	C331	C-CER,CHIP	SA
2203-006824	C349	C-CER,CHIP	SA
2203-006825	C230	C-CER,CHIP	SA
2203-006825	C258	C-CER,CHIP	SA
2203-006825	C529	C-CER,CHIP	SA
2203-006825	C668	C-CER,CHIP	SA
2203-006838	C209	C-CER,CHIP	SA
2203-006838	C459	C-CER,CHIP	SA
2203-006838	C530	C-CER,CHIP	SA
2203-006838	C602	C-CER,CHIP	SA
2203-006838	C603	C-CER,CHIP	SA
2203-006839	C304	C-CER,CHIP	SA
2203-006839	C306	C-CER,CHIP	SA
2203-006839	C307	C-CER,CHIP	SA
2203-006839	C308	C-CER,CHIP	SA
2203-006839	C309	C-CER,CHIP	SA
2203-006839	C311	C-CER,CHIP	SA
2203-006839	C343	C-CER,CHIP	SA
2203-006839	C412	C-CER,CHIP	SA
2203-006839	C414	C-CER,CHIP	SA
2203-006839	C460	C-CER,CHIP	SA
2203-006839	C467	C-CER,CHIP	SA
2203-006839	C468	C-CER,CHIP	SA
2203-006841	C315	C-CER,CHIP	SA
2203-006841	C338	C-CER,CHIP	SA
2203-006841	C341	C-CER,CHIP	SA
2203-006841	C344	C-CER,CHIP	SA
2203-006872	C131	C-CER,CHIP	SA
2203-006872	C141	C-CER,CHIP	SA

SEC CODE	Design LOC	Discription	STATUS
2203-006872	C316	C-CER,CHIP	SA
2203-006872	C320	C-CER,CHIP	SA
2203-006872	C321	C-CER,CHIP	SA
2203-006872	C322	C-CER,CHIP	SA
2203-006872	C324	C-CER,CHIP	SA
2203-006872	C348	C-CER,CHIP	SA
2203-006872	C435	C-CER,CHIP	SA
2203-006872	C626	C-CER,CHIP	SA
2203-006872	C654	C-CER,CHIP	SA
2203-006872	C681	C-CER,CHIP	SA
2203-006885	C410	C-CER,CHIP	SA
2203-006890	C127	C-CER,CHIP	SA
2203-006979	C138	C-CER,CHIP	SA
2203-006979	C177	C-CER,CHIP	SA
2203-006979	C189	C-CER,CHIP	SA
2203-006979	C408	C-CER,CHIP	SA
2203-006979	C520	C-CER,CHIP	SA
2404-001268	C339	C-TA,CHIP	SA
2404-001268	C340	C-TA,CHIP	SA
2404-001381	C314	C-TA,CHIP	SA
2404-001381	C407	C-TA,CHIP	SA
2404-001381	C509	C-TA,CHIP	SA
2404-001381	TA100	C-TA,CHIP	SA
2404-001381	TA101	C-TA,CHIP	SA
2404-001381	TA201	C-TA,CHIP	SA
2404-001381	TA202	C-TA,CHIP	SA
2404-001381	TA300	C-TA,CHIP	SA
2404-001465	C632	C-TA,CHIP	SA
2404-001465	C665	C-TA,CHIP	SA
2404-001474	C185	C-TA,CHIP	SA
2404-001496	C424	C-TA,CHIP	SA
2703-001722	L112	INDUCTOR-SMD	SA
2703-001734	L125	INDUCTOR-SMD	SA
2703-001750	L122	INDUCTOR-SMD	SA
2703-001750	L126	INDUCTOR-SMD	SA
2703-002176	L104	INDUCTOR-SMD	SA
2703-002207	L114	INDUCTOR-SMD	SA

Main Electrical Parts List

SEC CODE	Design LOC	Discription	STATUS
2703-002313	L611	INDUCTOR-SMD	SA
2703-002369	L118	INDUCTOR-SMD	SA
2703-002544	L117	INDUCTOR-SMD	SA
2703-002597	L115	INDUCTOR-SMD	SA
2703-002619	L303	INDUCTOR-SMD	SA
2703-002795	L103	INDUCTOR-SMD	SNA
2703-002858	L106	INDUCTOR-SMD	SA
2703-002858	L108	INDUCTOR-SMD	SA
2703-002870	L100	INDUCTOR-SMD	SA
2703-002872	L300	INDUCTOR-SMD	SA
2703-002872	L301	INDUCTOR-SMD	SA
2703-002872	L302	INDUCTOR-SMD	SA
2703-002901	L101	INDUCTOR-SMD	SNA
2703-002906	L102	INDUCTOR-SMD	SA
2703-002917	L111	INDUCTOR-SMD	SA
2703-003260	L500	INDUCTOR-SMD	SA
2801-004339	OSC300	CRYSTAL-SMD	SA
2801-004573	OSC500	CRYSTAL-SMD	SA
2809-001280	TCX100	OSCILLATOR-VCTCXO	SA
2901-001470	F401	FILTER-EMI SMD	SA
2901-001470	F402	FILTER-EMI SMD	SA
2901-001470	F403	FILTER-EMI SMD	SA
2904-001658	F101	FILTER-SAW	SA
2904-001702	F100	FILTER-SAW	SA
2910-000039	DUF100	DUPLEXER-FBAR	SA
2911-000096	FEM100	DUPLEXER-FEM	SA
3301-001438	L400	BEAD-SMD	SA
3301-001438	L401	BEAD-SMD	SA
3301-001438	L402	BEAD-SMD	SA
3301-001438	L404	BEAD-SMD	SA
3301-001534	L407	BEAD-SMD	SA
3301-001534	L408	BEAD-SMD	SA
3301-001534	L409	BEAD-SMD	SA
3301-001534	L501	BEAD-SMD	SA
3301-001534	L200	BEAD-SMD	SA
3301-001534	L201	BEAD-SMD	SA
3301-001534	L202	BEAD-SMD	SA

SEC CODE	Design LOC	Discription	STATUS
3301-001534	L300	BEAD-SMD	SA
3301-001534	L301	BEAD-SMD	SA
3301-001756	L608	BEAD-SMD	SA
3301-001756	L610	BEAD-SMD	SA
3301-001879	L100	BEAD-SMD	SA
3301-001879	L101	BEAD-SMD	SA
3301-001879	L102	BEAD-SMD	SA
3301-001879	L103	BEAD-SMD	SA
3408-001132	SW200	SWITCH-SLIDE	SA
3705-001358	RFS100	CONNECTOR-COAXIAL	SA
3708-001912	SLC301	CONNECTOR-FPC/FFC/PIC	SA
3708-001966	SLC300	CONNECTOR-FPC/FFC/PIC	SA
3708-002170	SLC201	CONNECTOR-FPC/FFC/PIC	SA
3708-002222	SLC200	CONNECTOR-FPC/FFC/PIC	SA
3709-001465	SIM400	CONNECTOR-CARD EDGE	SA
3710-002523	IFC400	SOCKET-INTERFACE	SA
3711-005367	HDC400	HEADER-BOARD TO BOARD	SA
3711-006256	BTC400	HEADER-BATTERY	SA
3711-006630	HDC401	HEADER-BOARD TO BOARD	SA
3711-006630	HDC402	HEADER-BOARD TO BOARD	SA
4202-001396	ANT602	ANTENNA-CHIP	SA
4302-001180	BAT300	BATTERY-LI(2ND)	SA
4709-001399	U104	COUPLER-DIRECTION	SA
4709-001525	U611	BLUETOOTH MODULE	SA
GH13-00061A	U503	IC ASIC-SGHF490	SA
GH42-01344A	QAN02	INTENNA-SGHF700	SA
GH59-05012A	QVK08	ASSY ETC-SGH-F700 EARJACK FP CB	SA
GH70-02367A	SC100	ICT-ON-BOARD CLIP	SA
GH70-02367A	SC101	ICT-ON-BOARD CLIP	SA
GH70-02367A	SC102	ICT-ON-BOARD CLIP	SA
GH70-02367A	SC103	ICT-ON-BOARD CLIP	SA
GH70-02367A	SC104	ICT-ON-BOARD CLIP	SA
GH70-02367A	SC105	ICT-ON-BOARD CLIP	SA
GH70-02367A	SC106	ICT-ON-BOARD CLIP	SA
GH70-02367A	SC107	ICT-ON-BOARD CLIP	SA
GH70-02367A	SC109	ICT-ON-BOARD CLIP	SA

SEC CODE	Design LOC	Discription	STATUS
GH70-02367A	SC110	ICT-ON-BOARD CLIP	SA
GH70-02965A	QSH01	ICT SHIELD-A	SA
GH70-02966A	QSH02	ICT SHIELD-B	SA
GH73-11265A	QAN05	RMO RUBBER-INTENNA	SA

Please consult the GSPN website (Samsung Portal) for the most recent version of the product's part list.

# 7. Block Diagrams

## 7-1. Base Band Solution Block Diagram

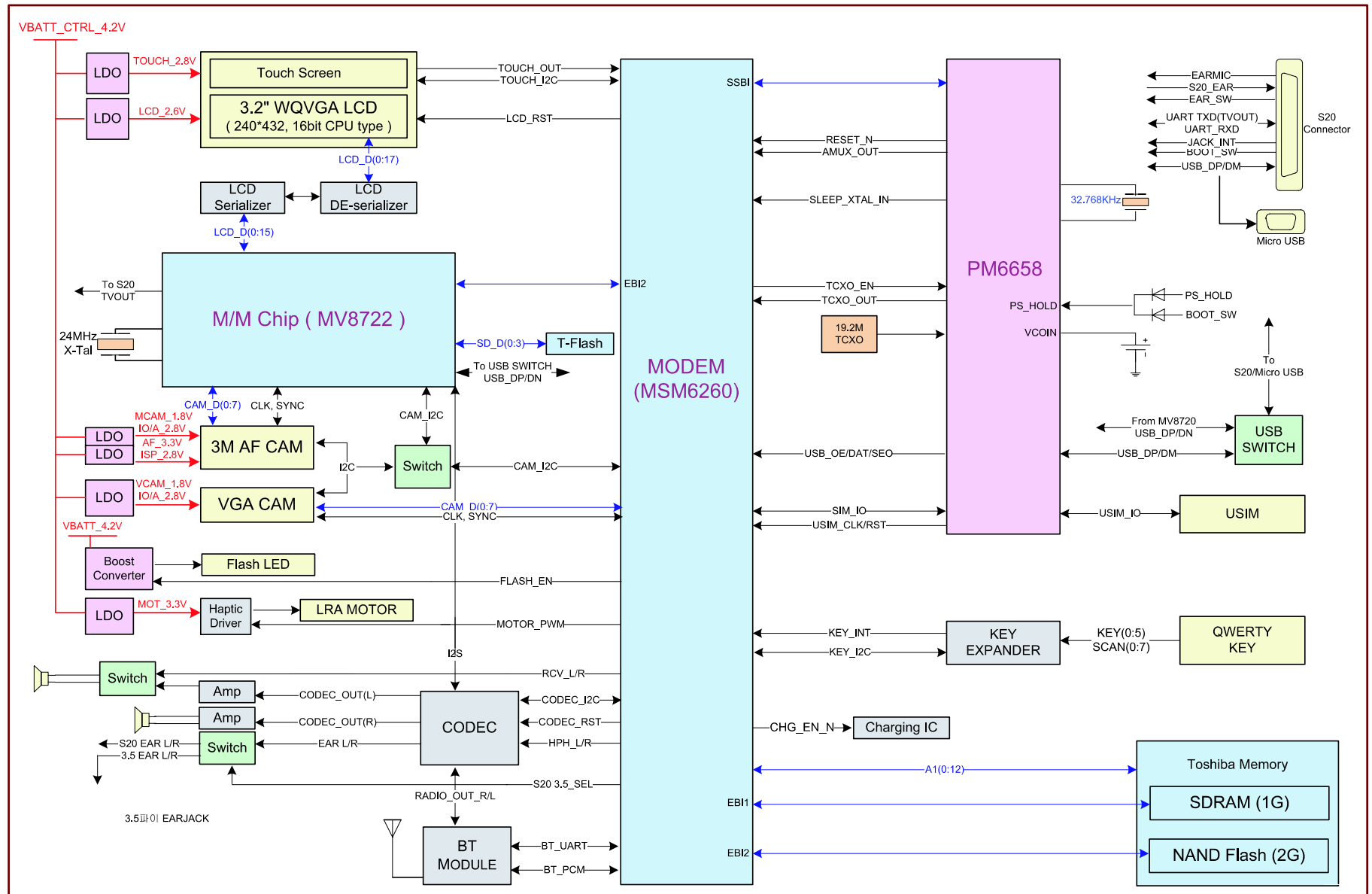

## 7-2. RF Solution Block Diagram

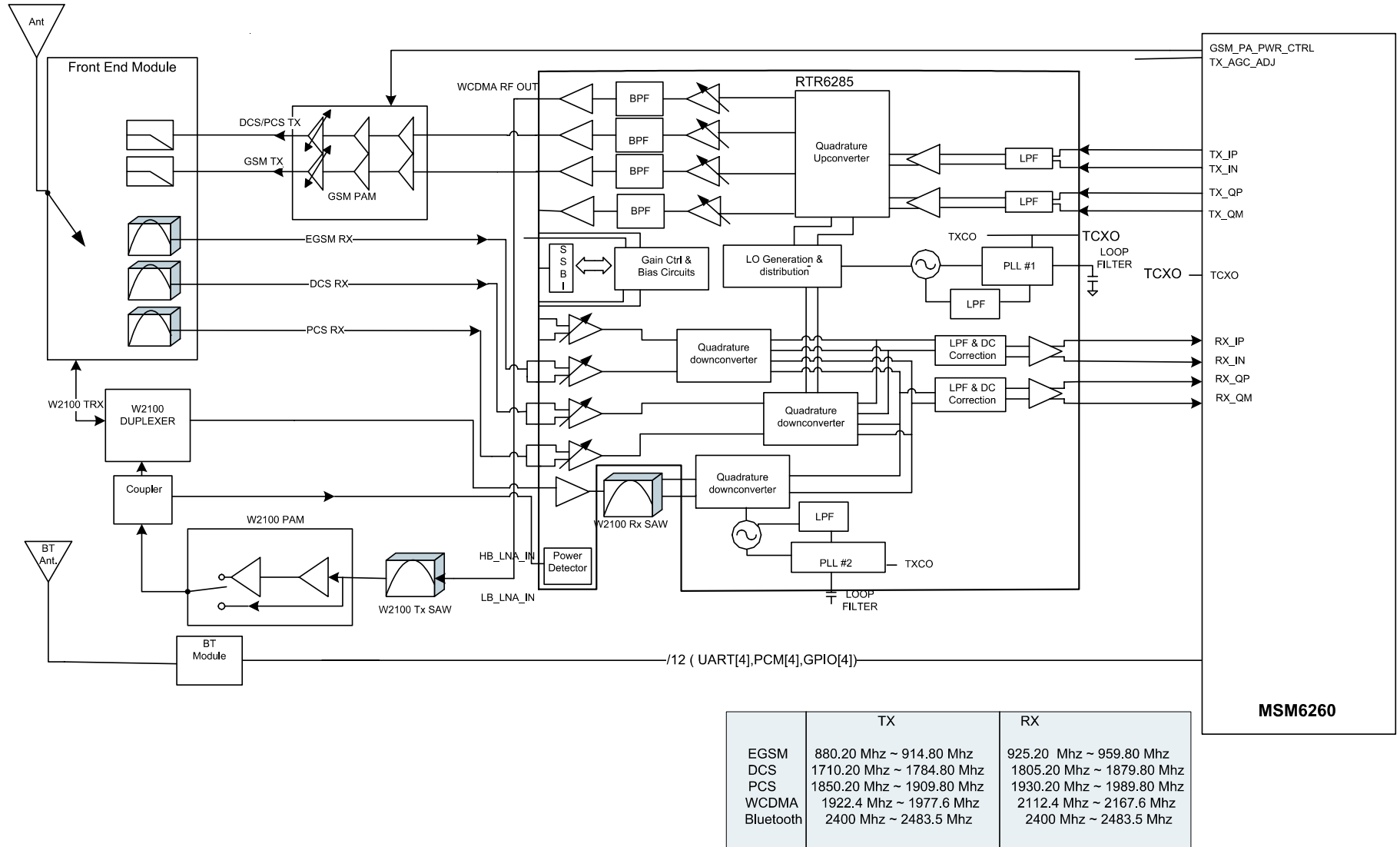

# 8. PCB Diagrams

## - Main top view

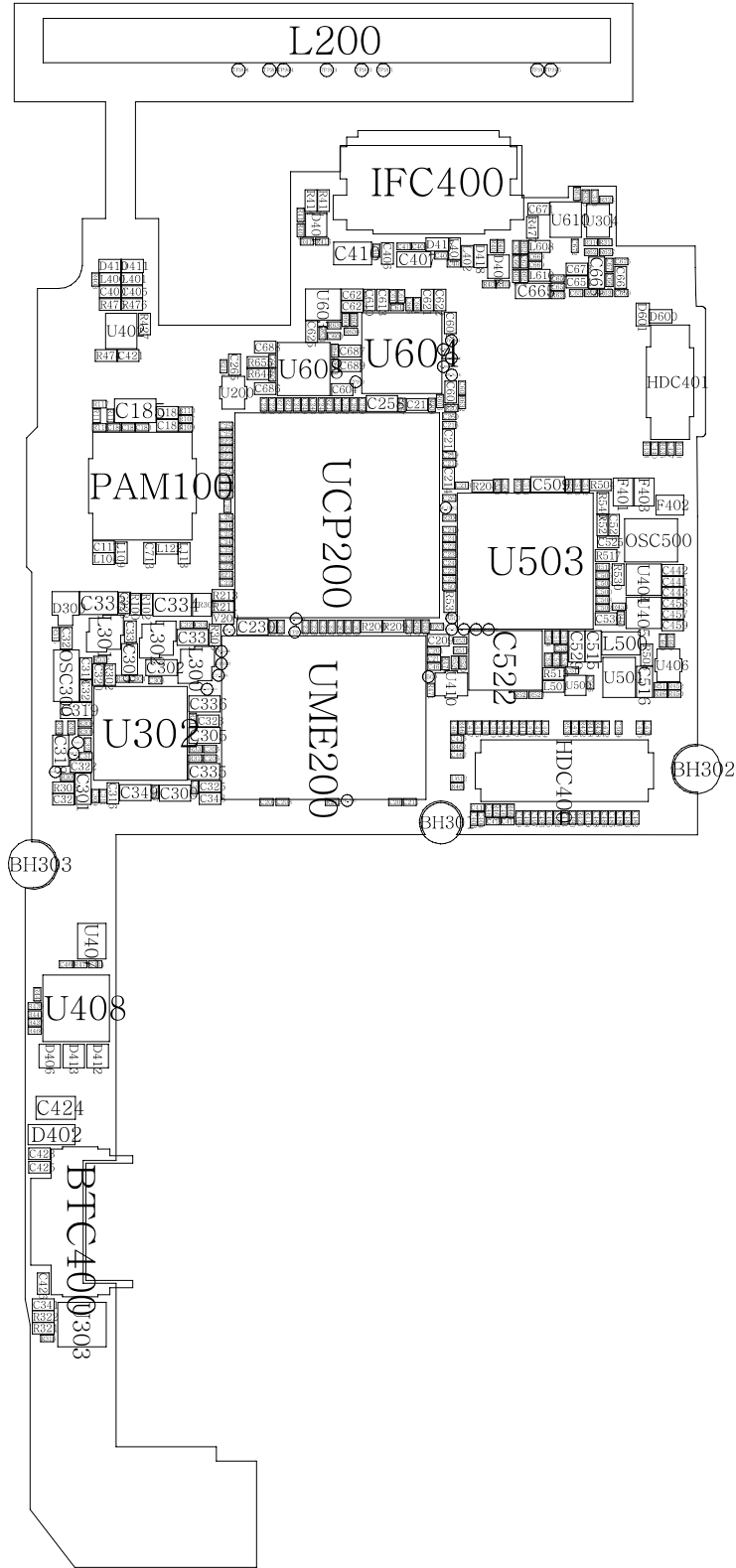

- Main bottom view

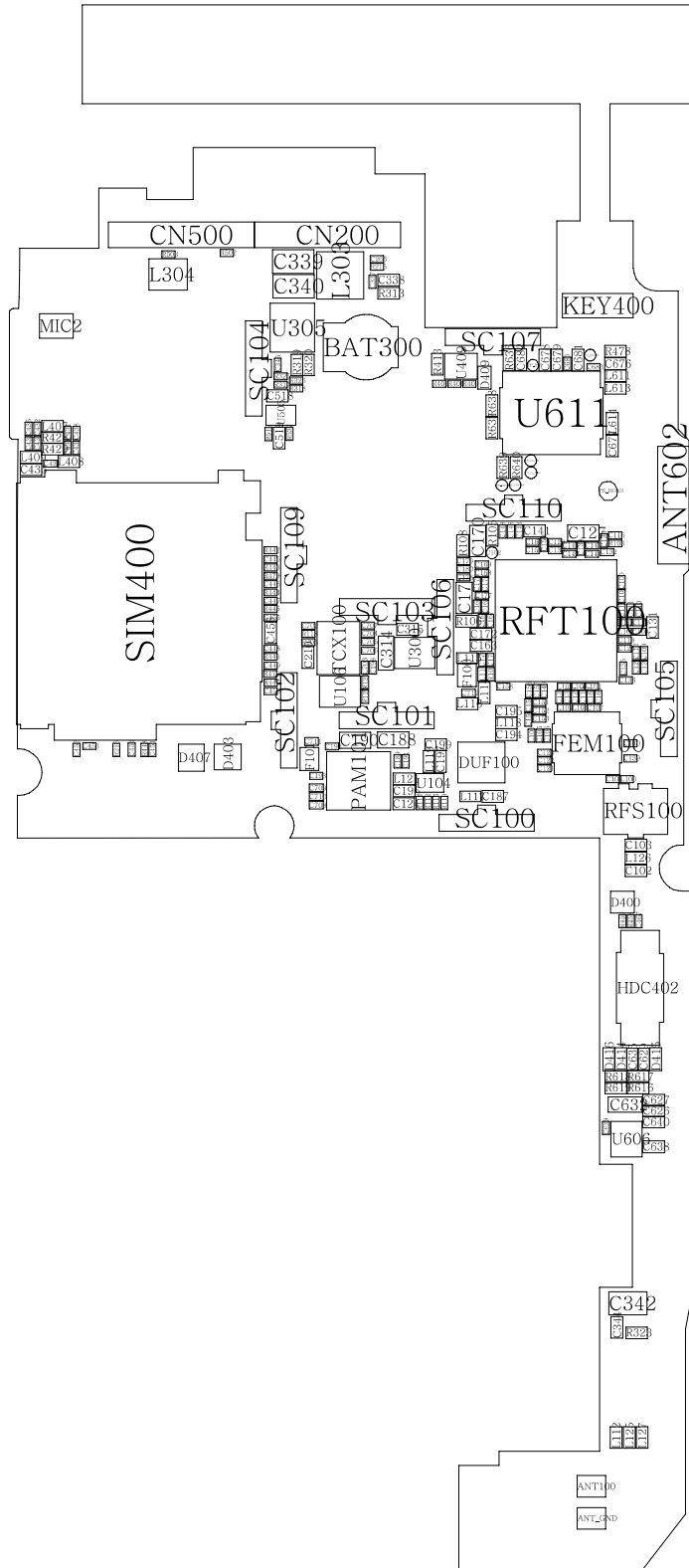

- Sub top view

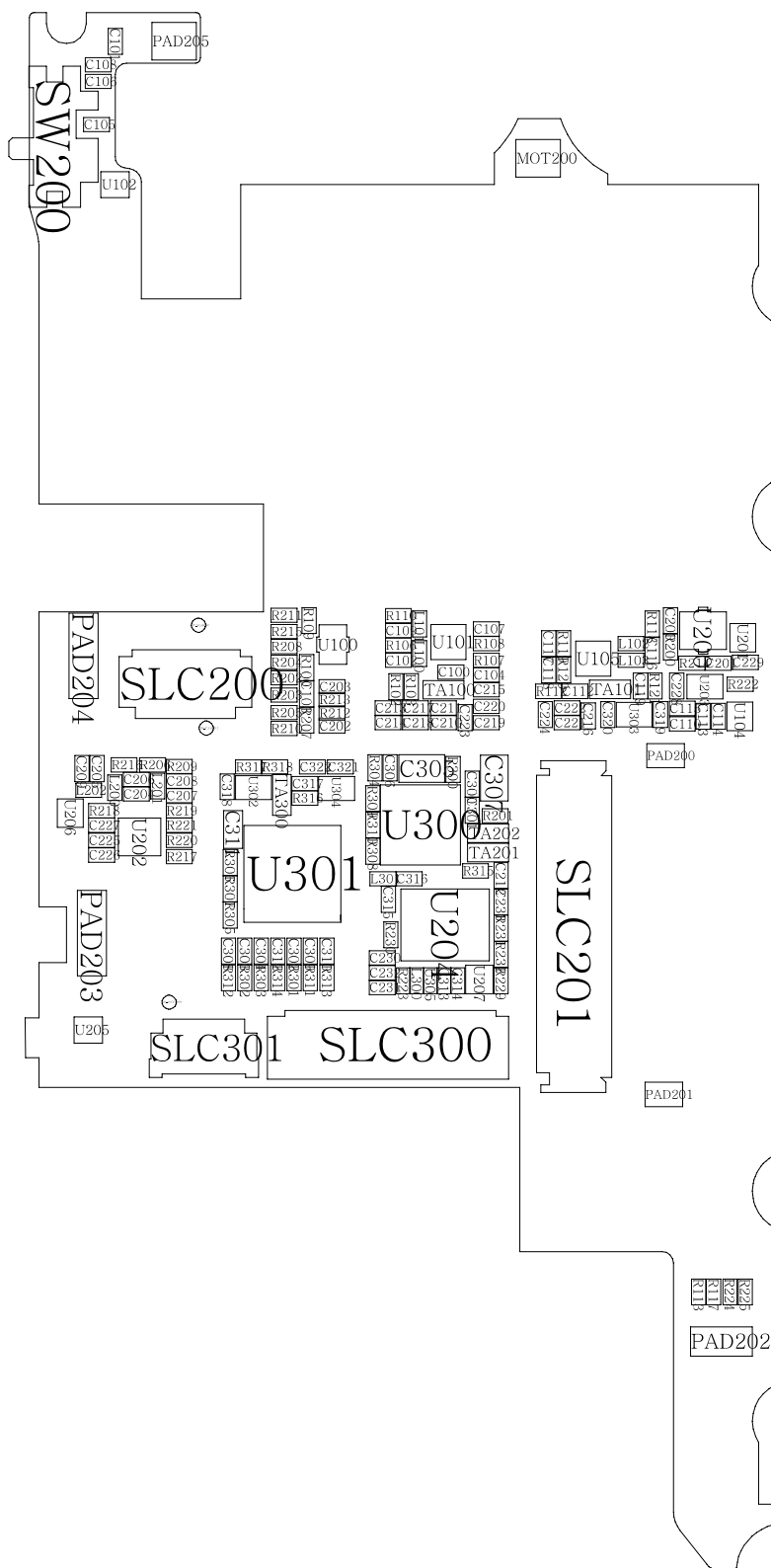

**- Sub bottom view**

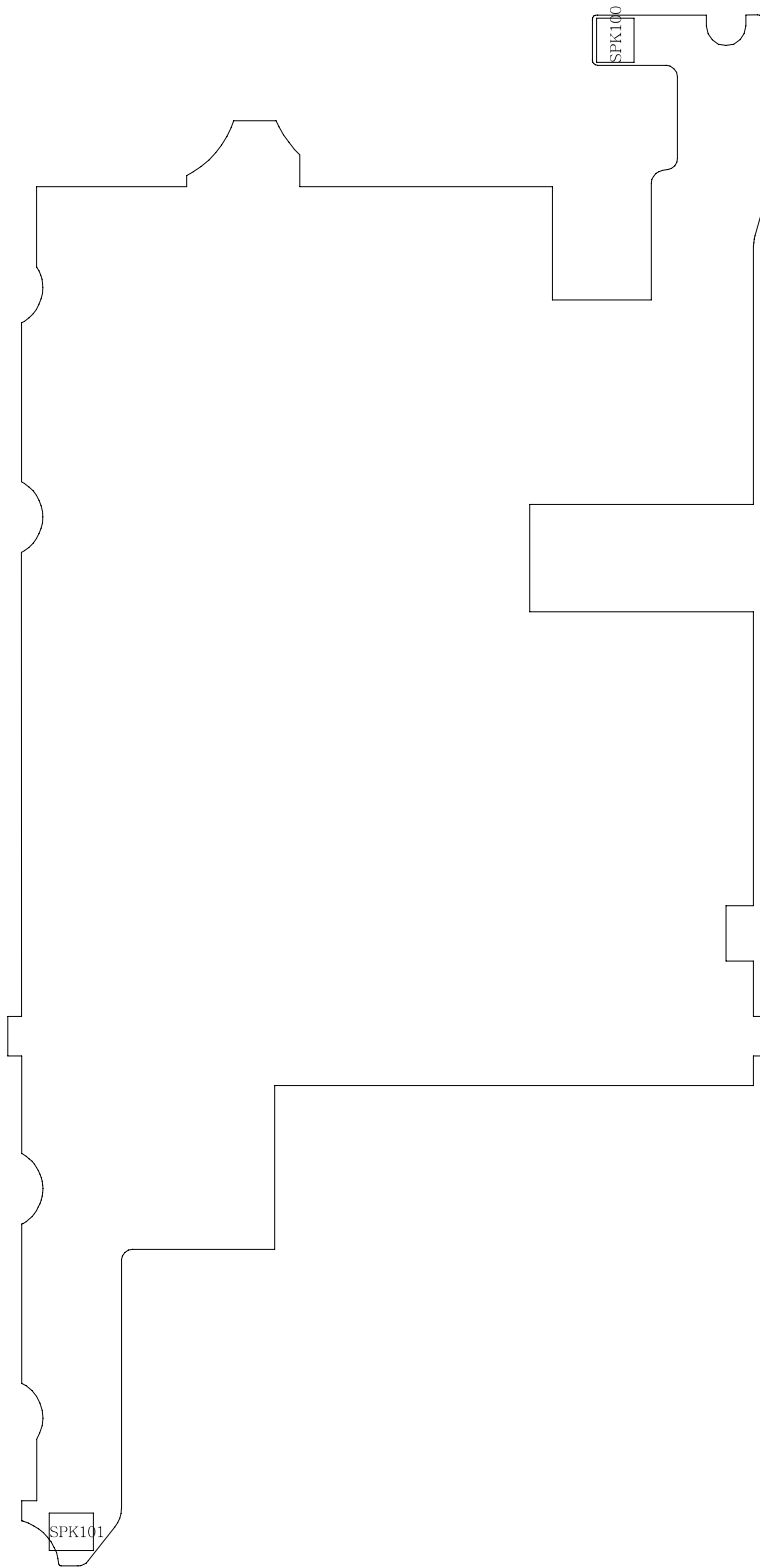

# 9. Flow Chart of Troubleshooting

## 9-1. Power On

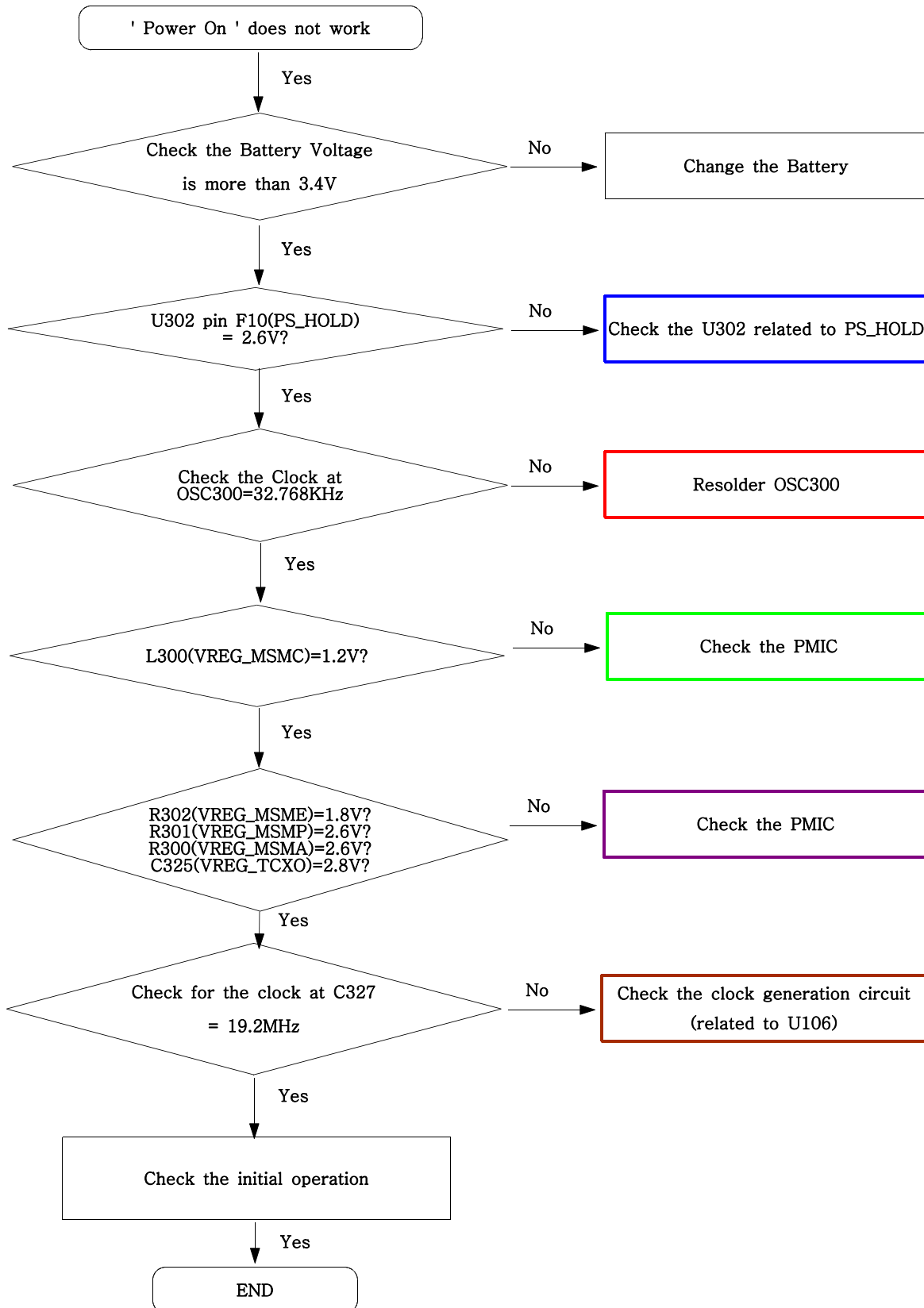

## < Power Management IC >

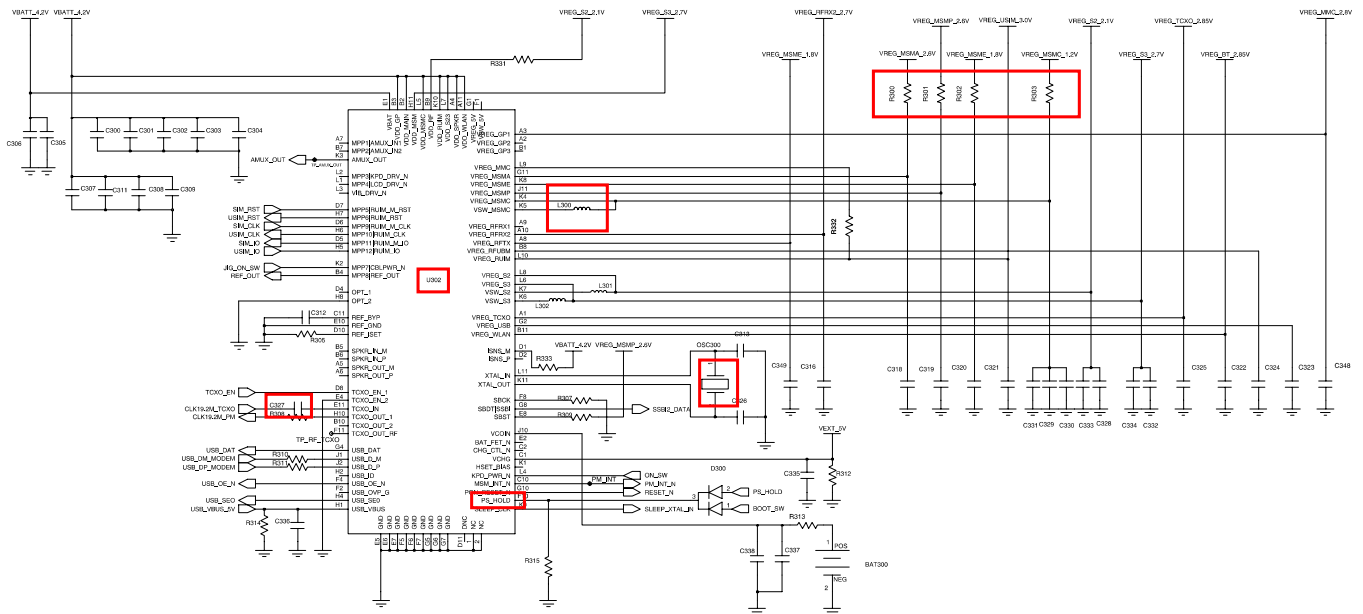

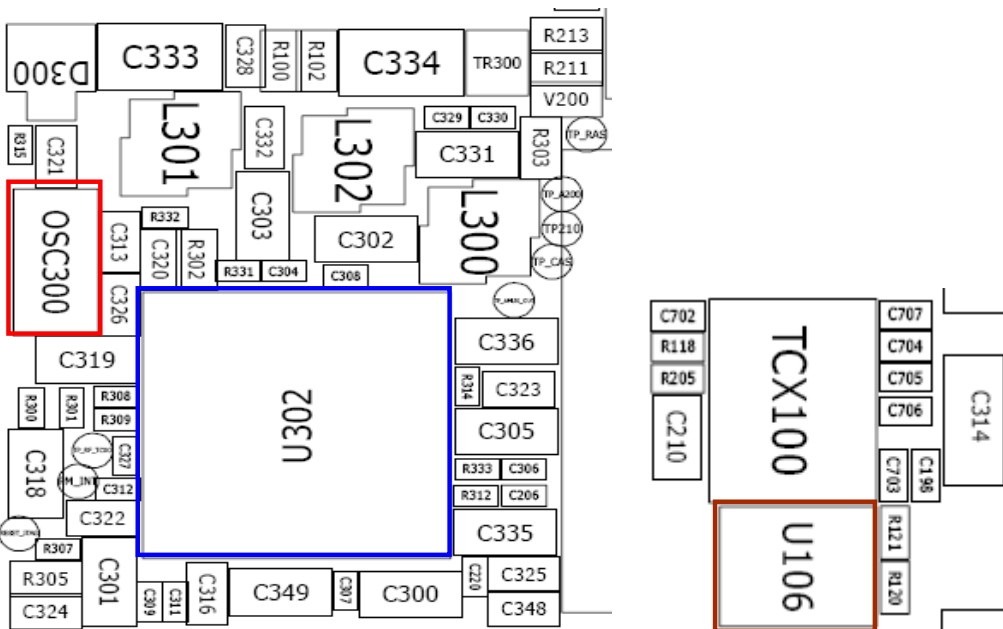
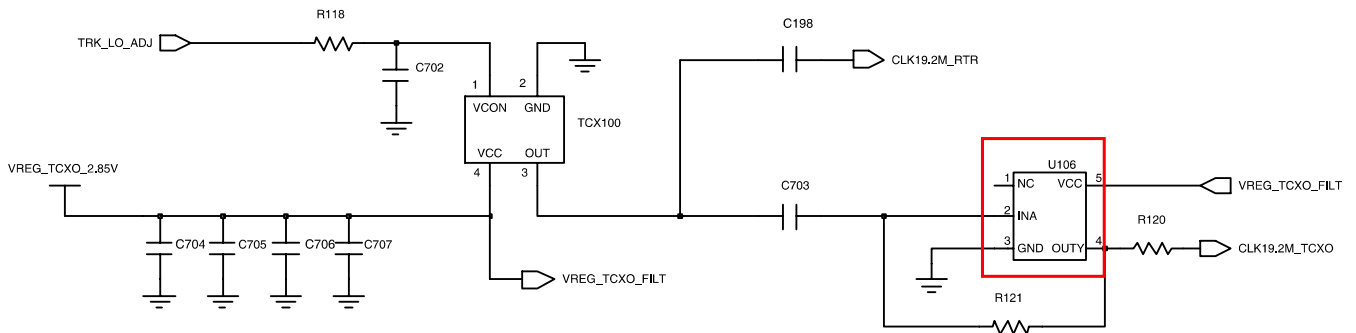

## 9-2. Initial

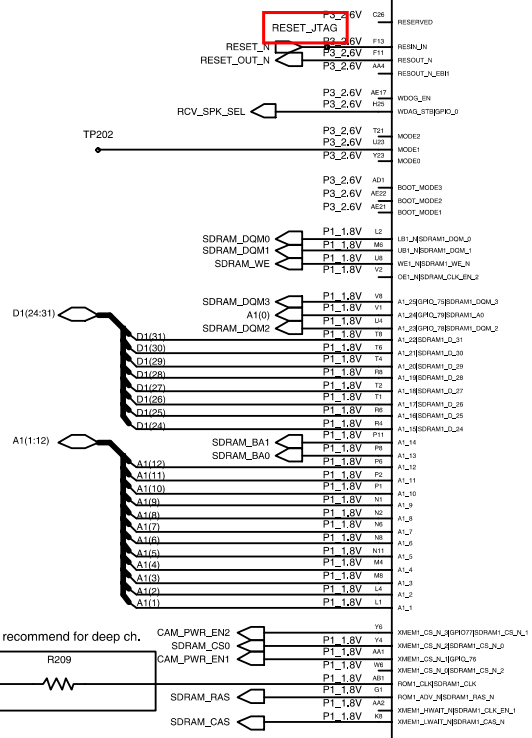
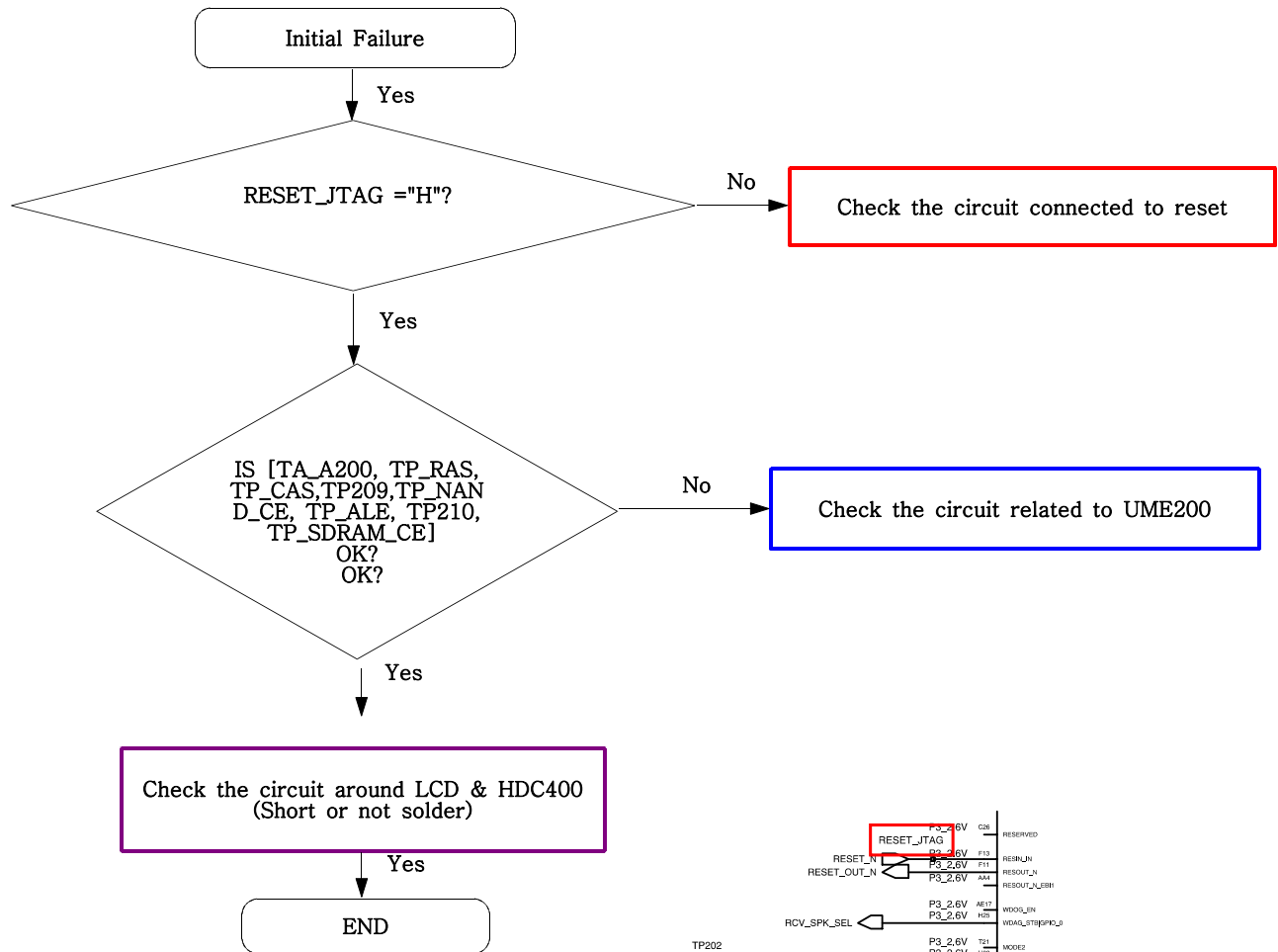

UCP200

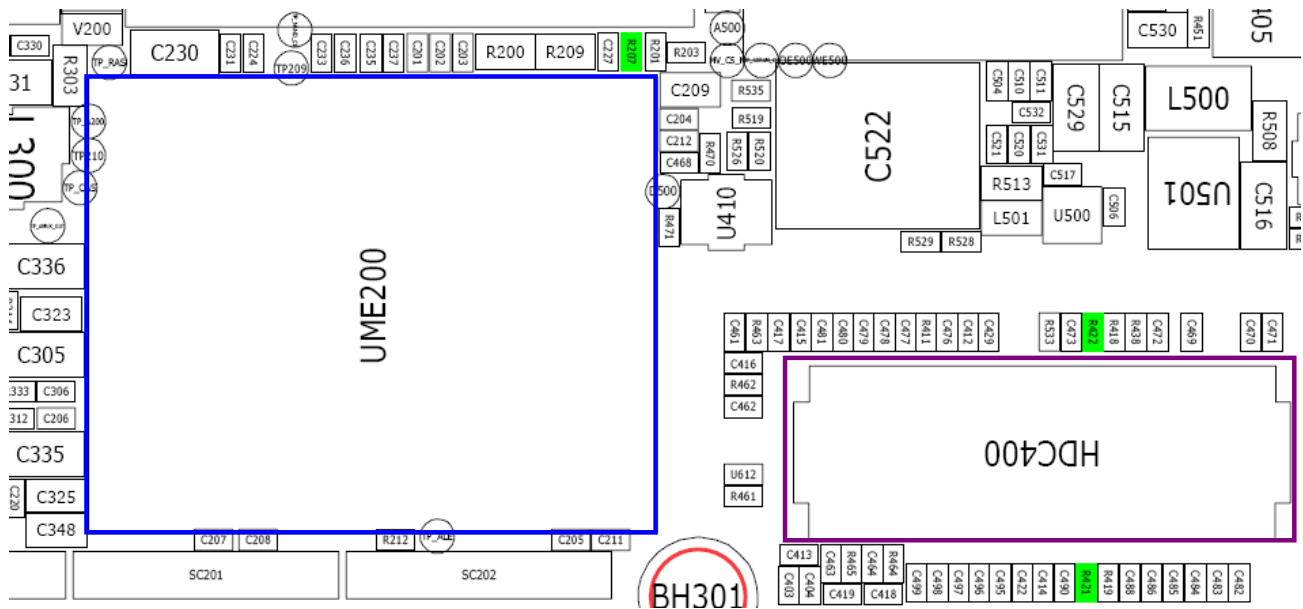

### 9-3. Charging Part

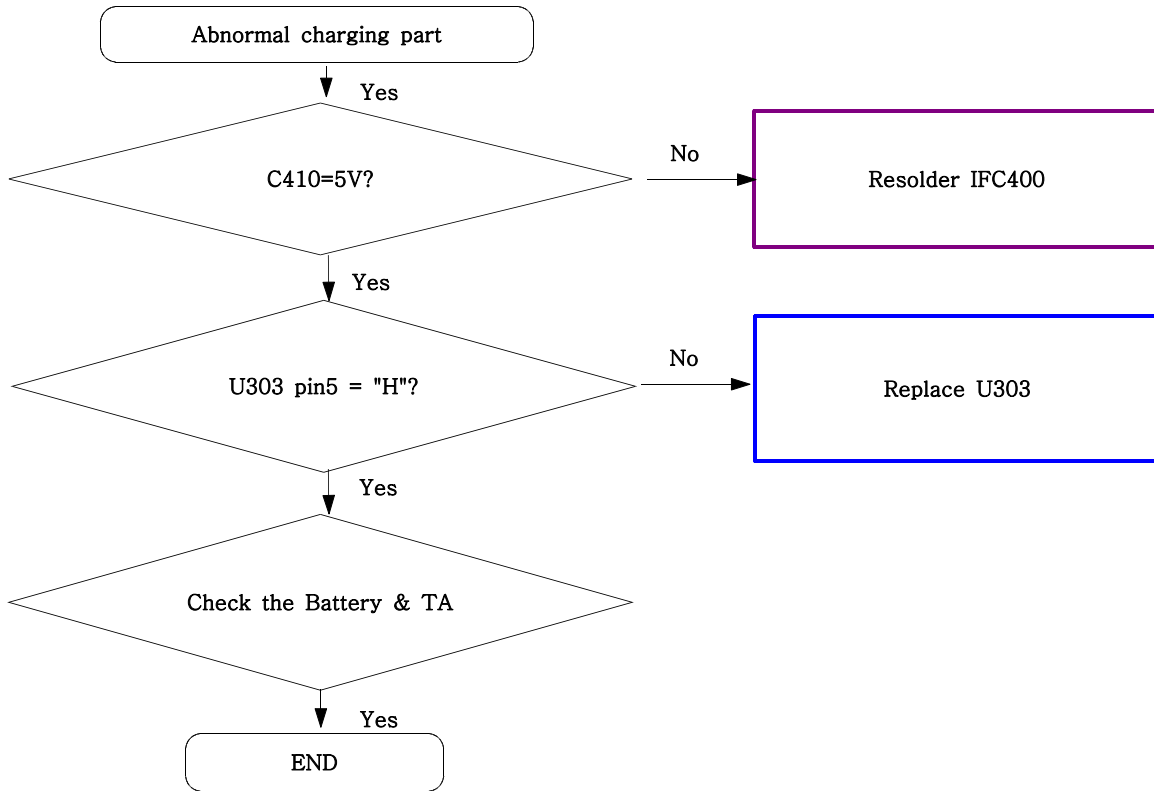

### < Charging IC >

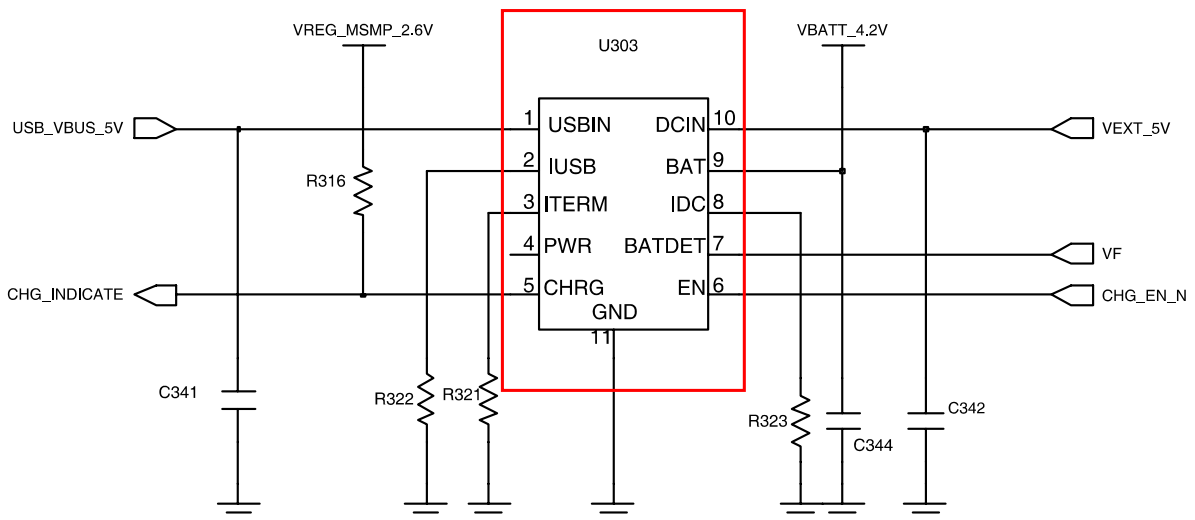

# Flow Chart of Troubleshooting

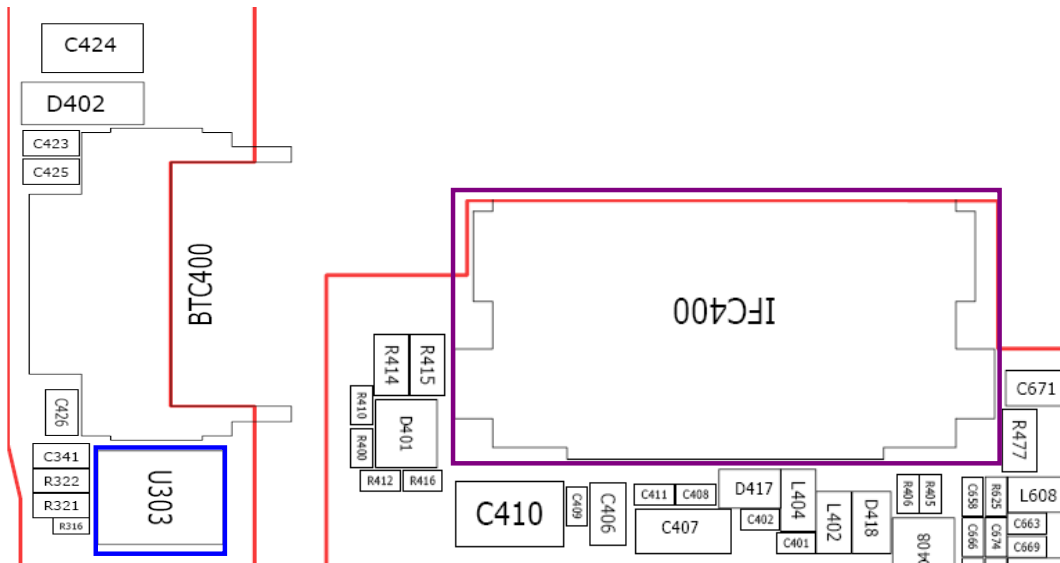
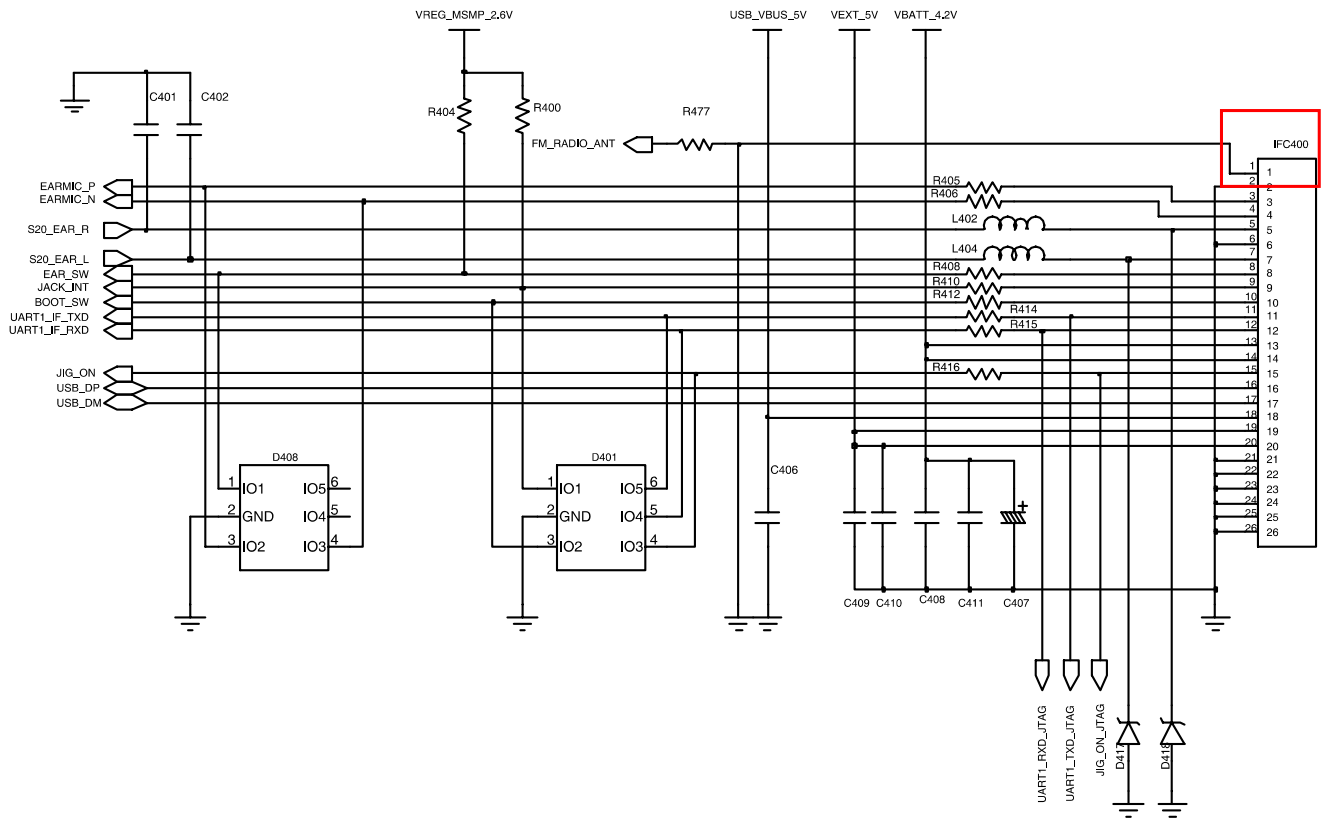

### 9-4. Sim Part

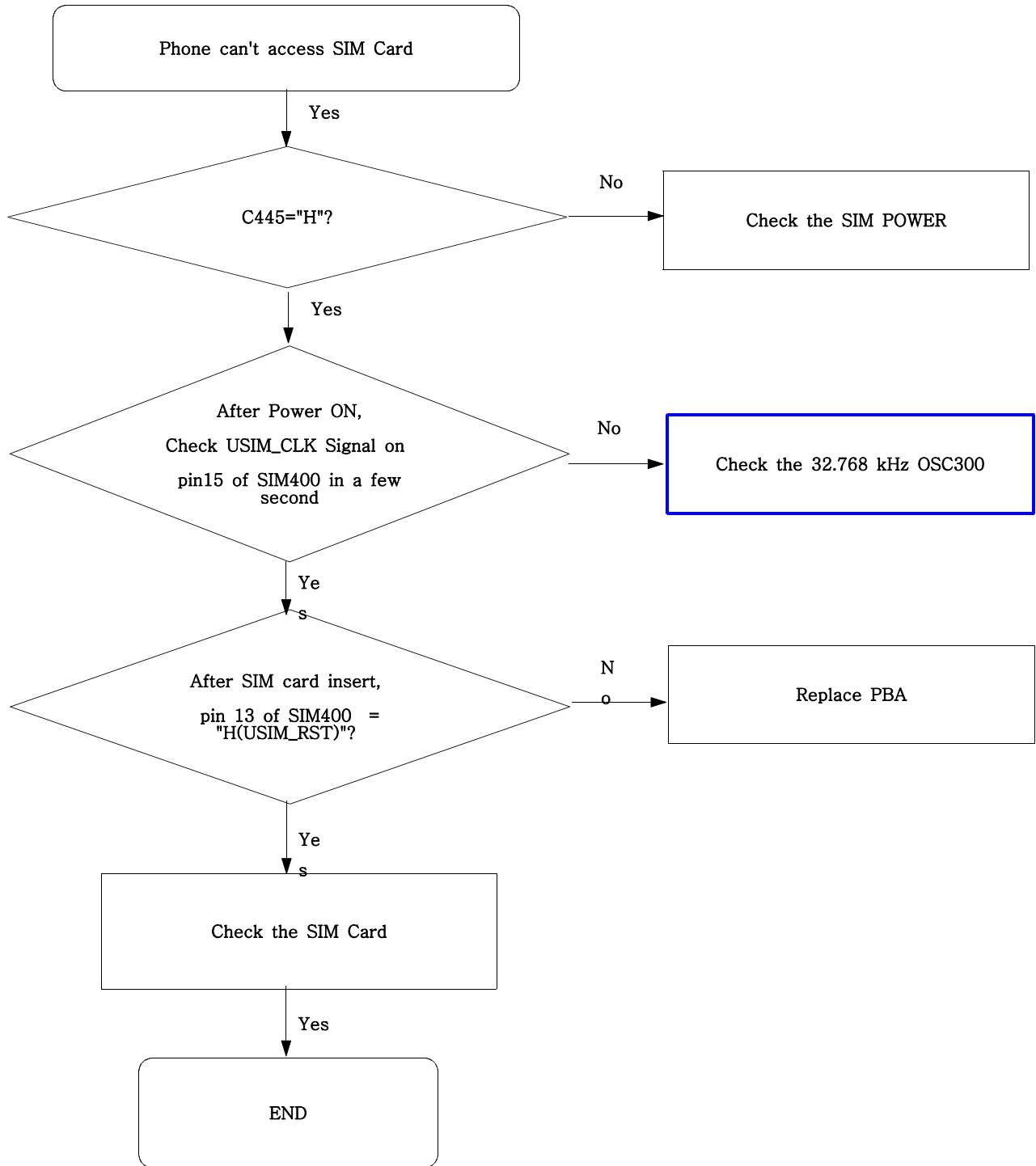

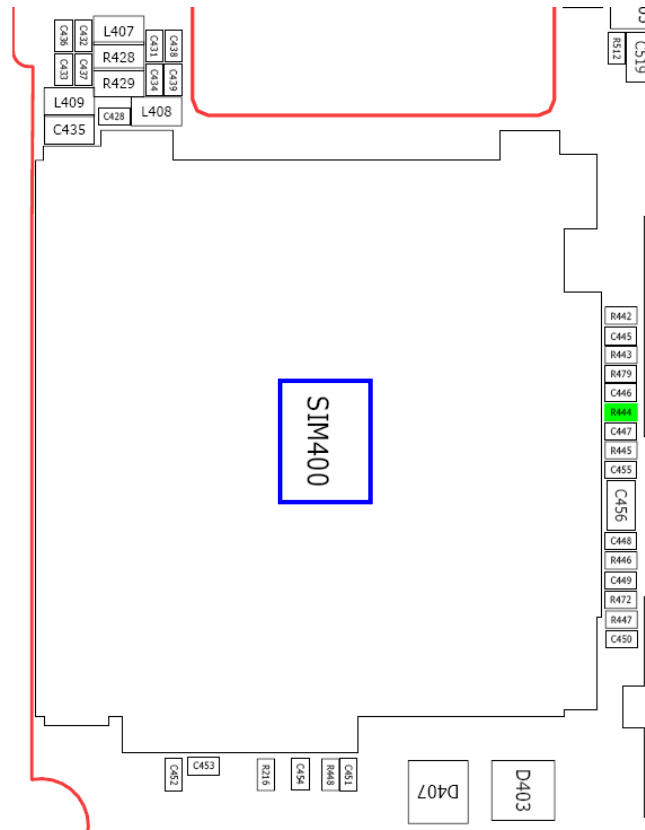
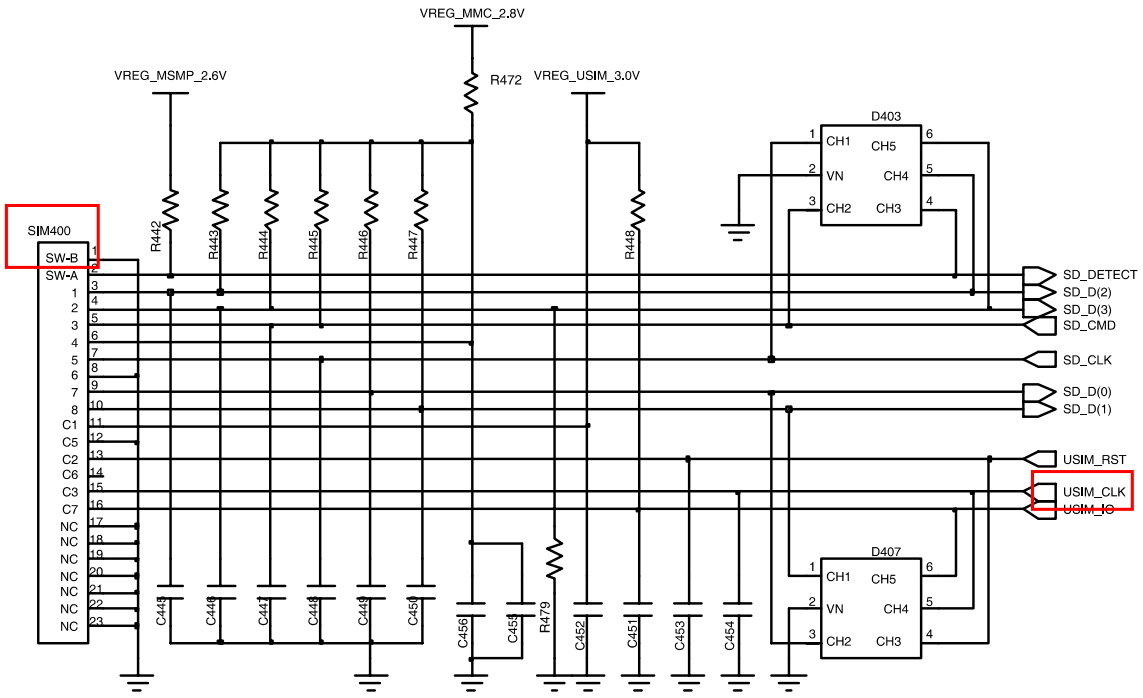

### 9-5. Microphone Part

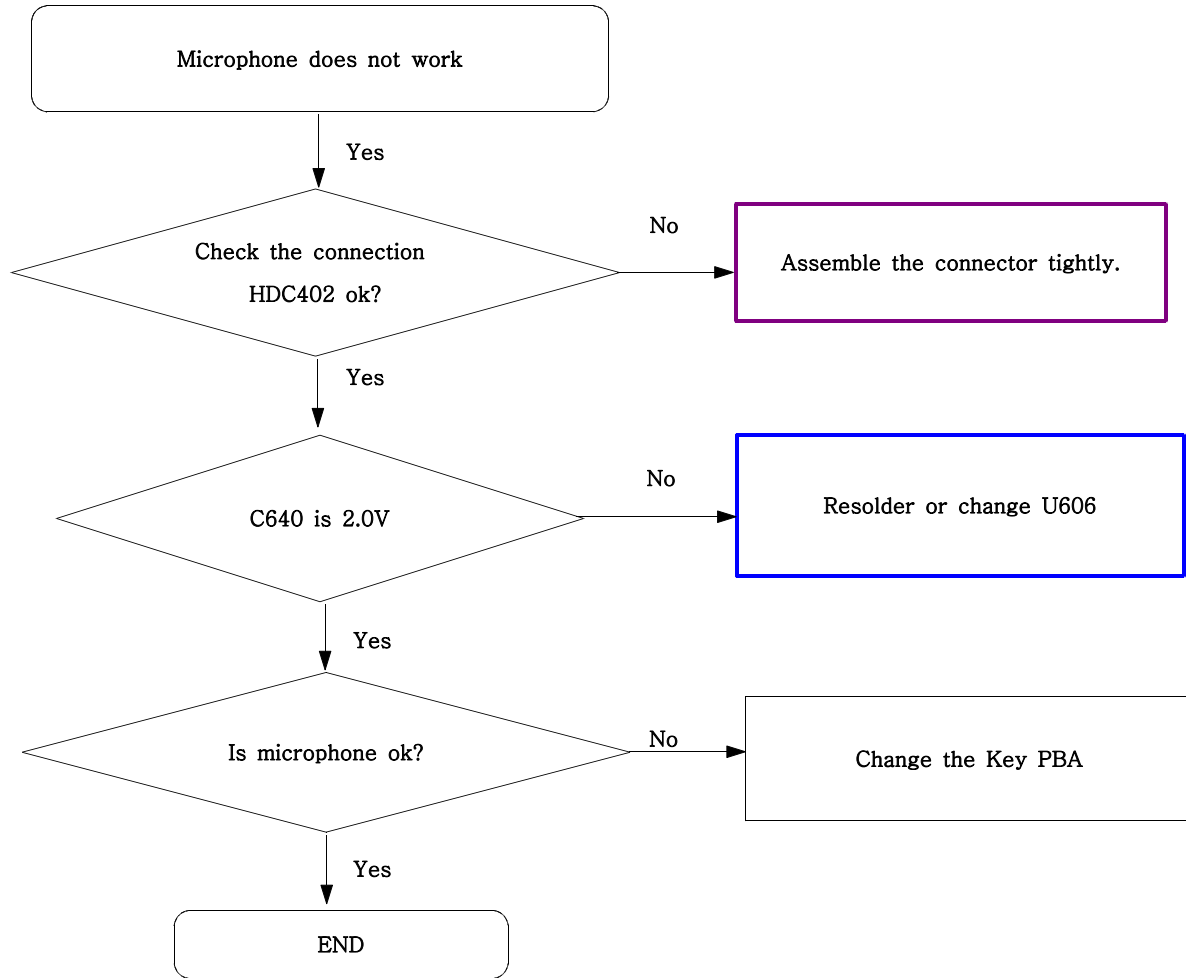

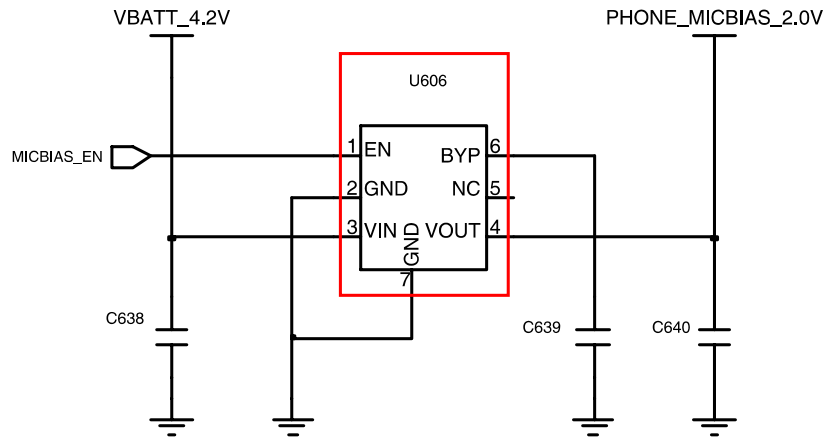

\*\*Placed near by Phone MIC

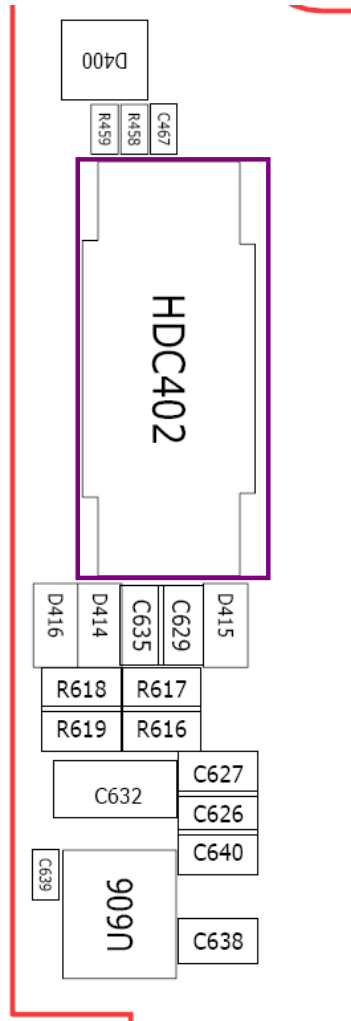

### 9-6. Speaker Part(Melody)

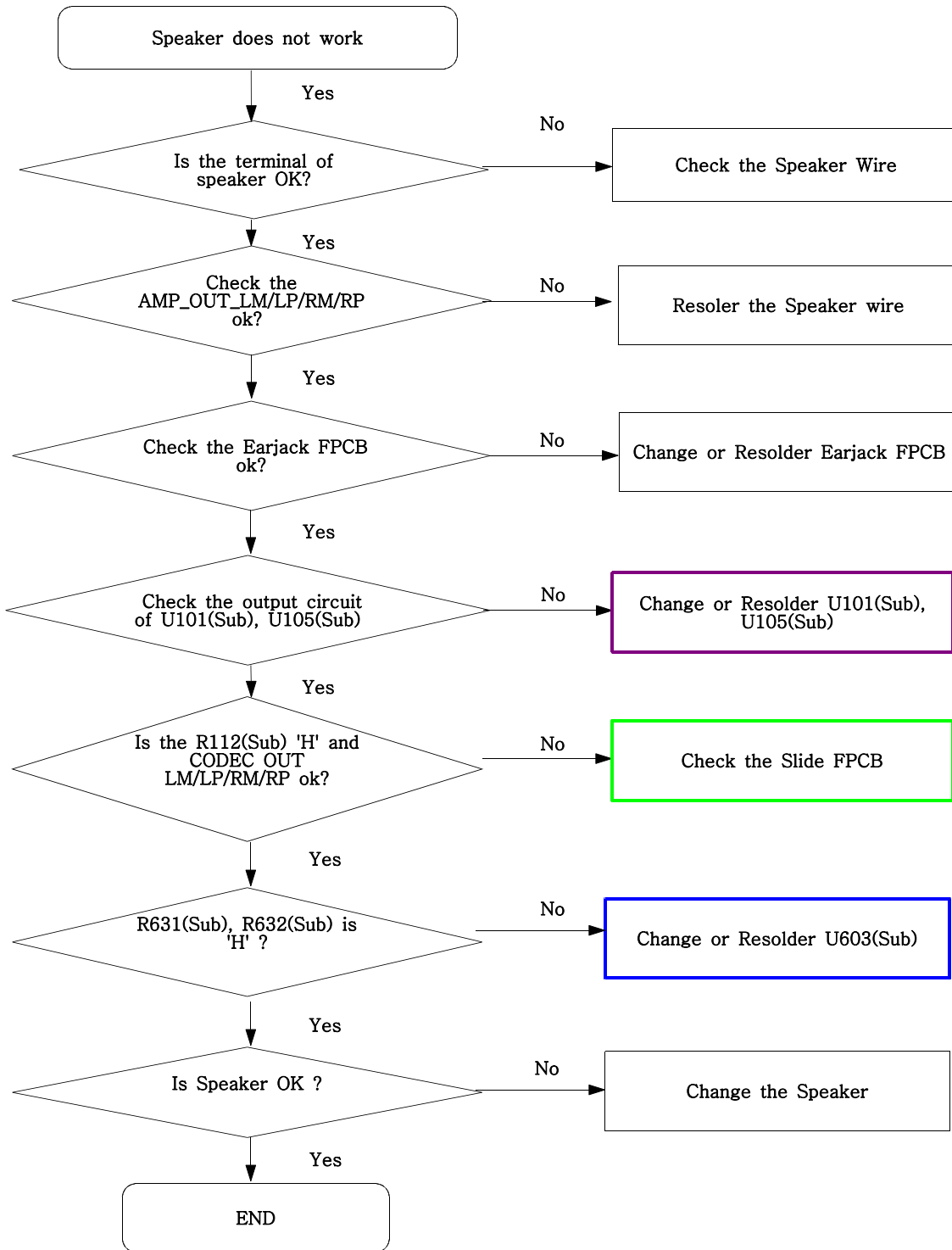

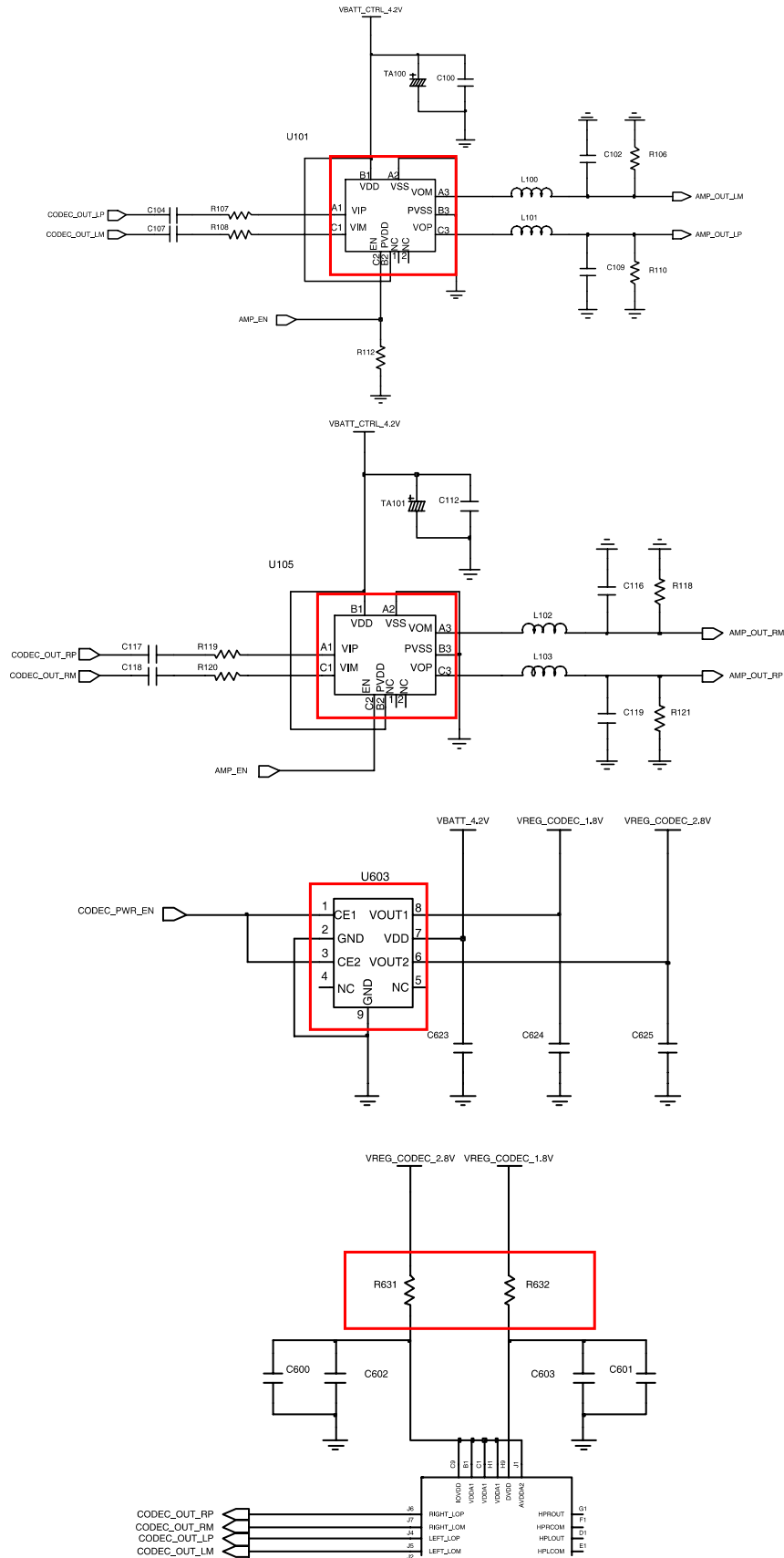



### 9-7. Key Data Input

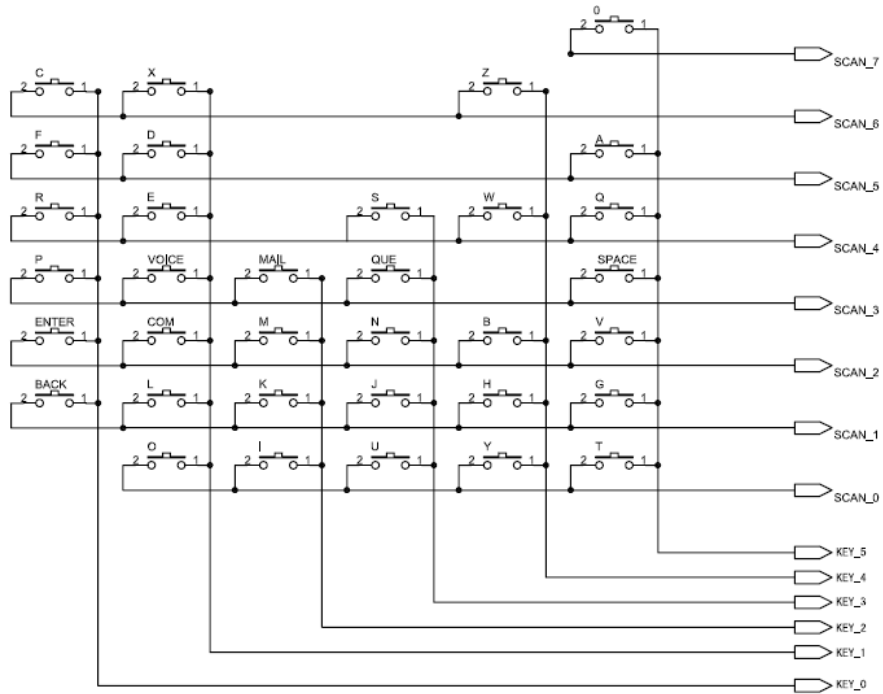
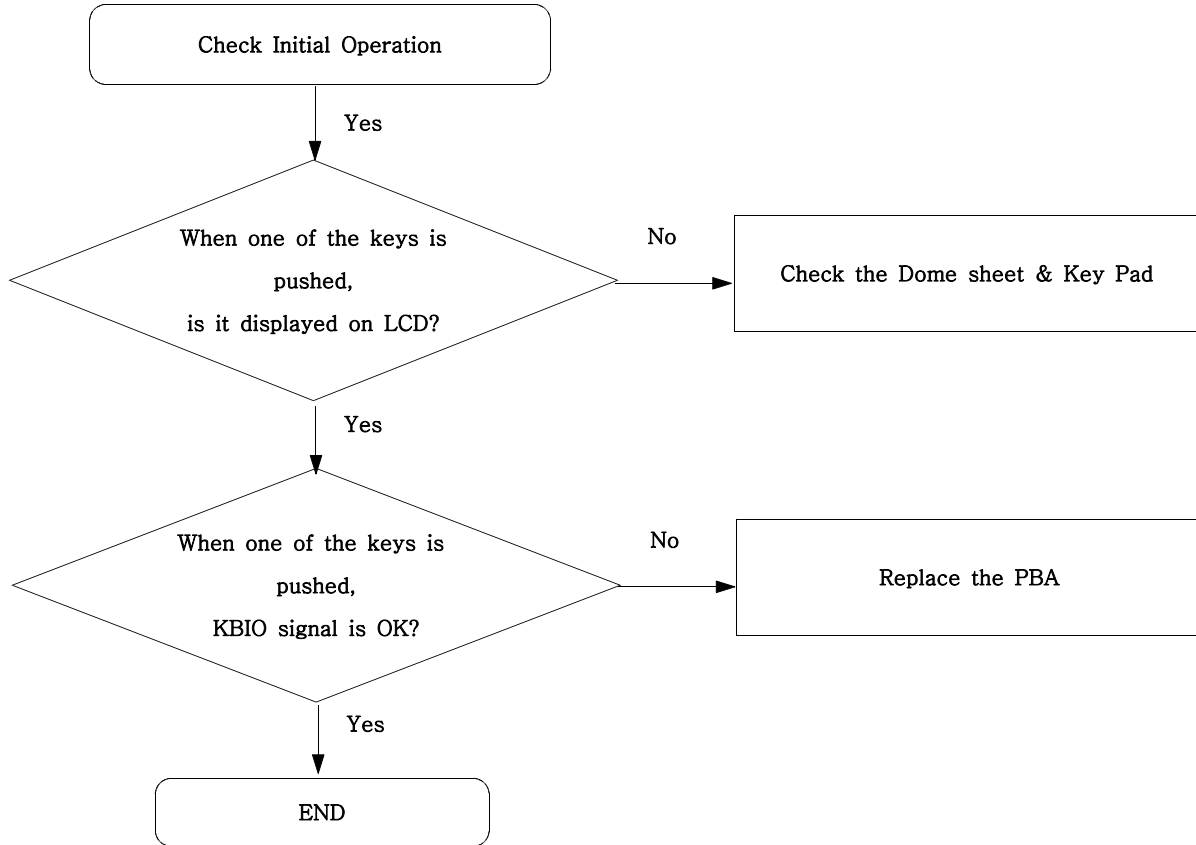

# Flow Chart of Troubleshooting

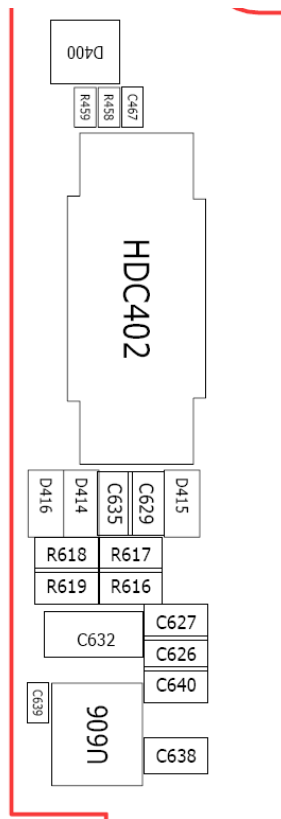
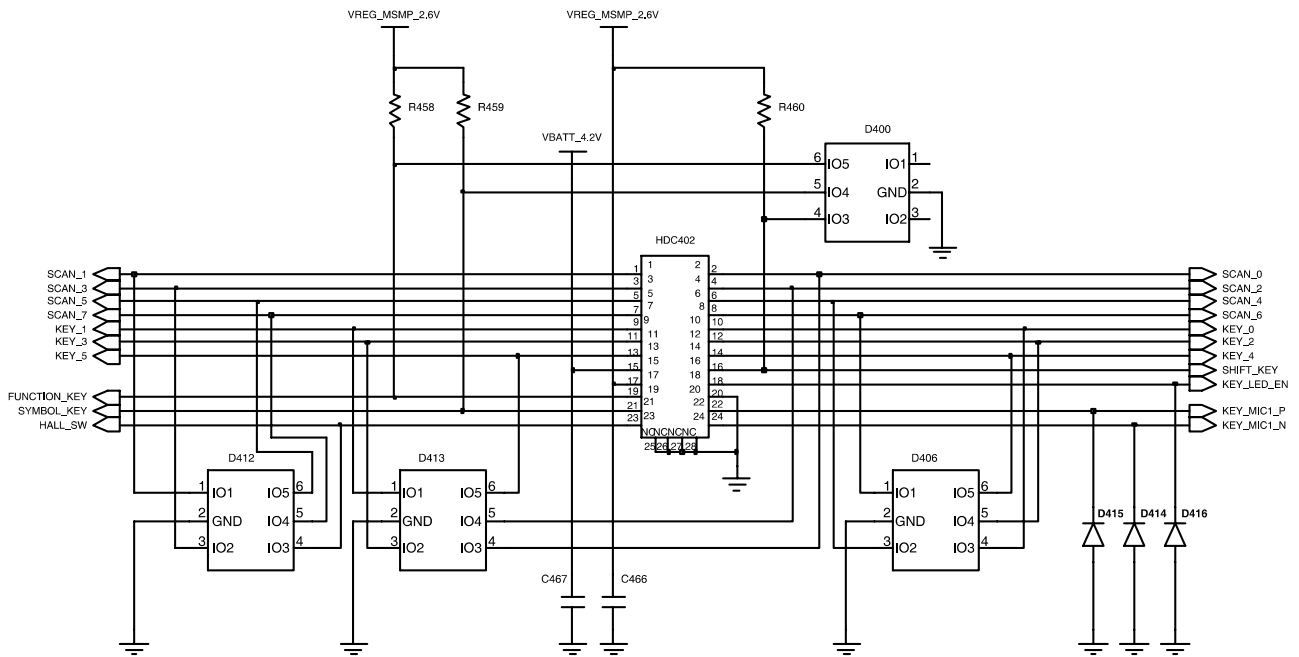

### 9-8. Receiver Part

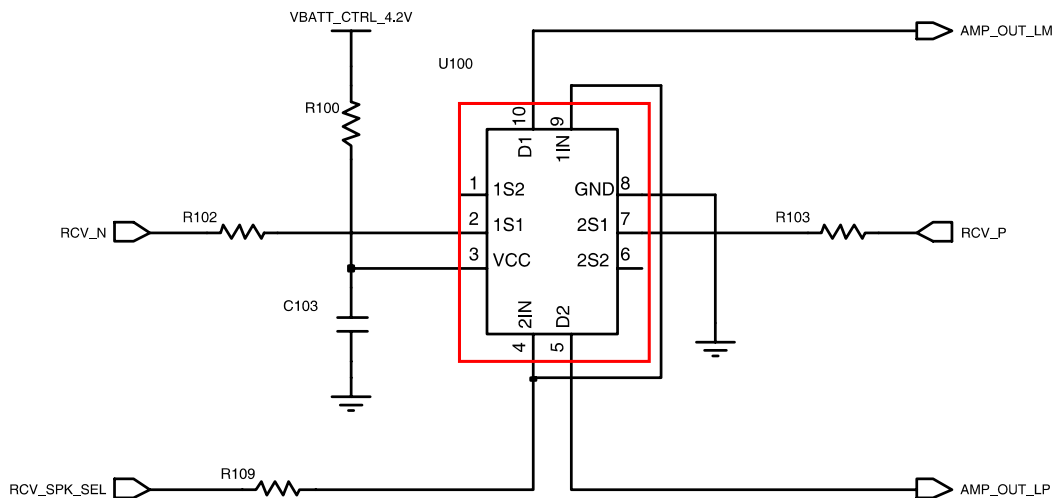
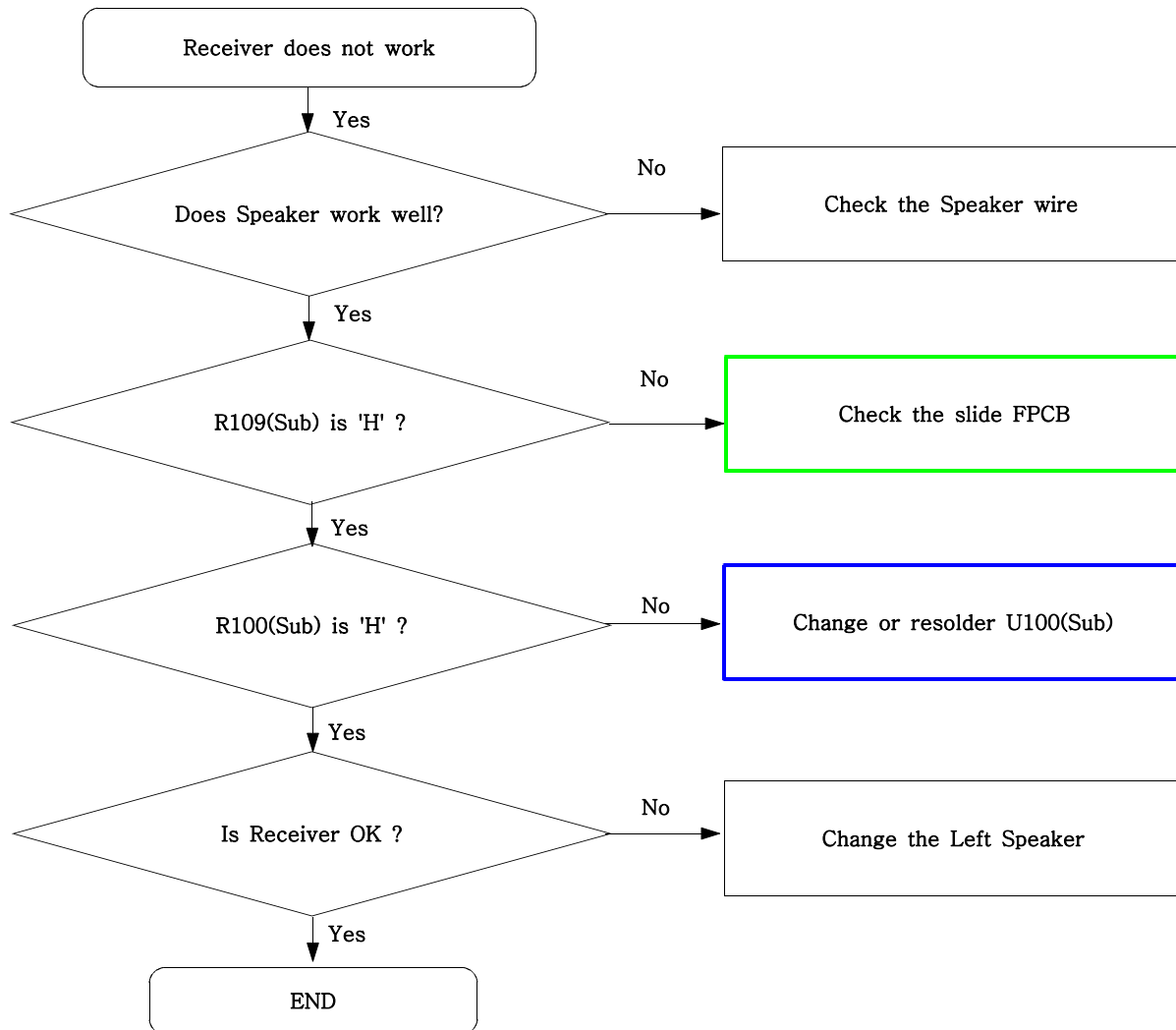

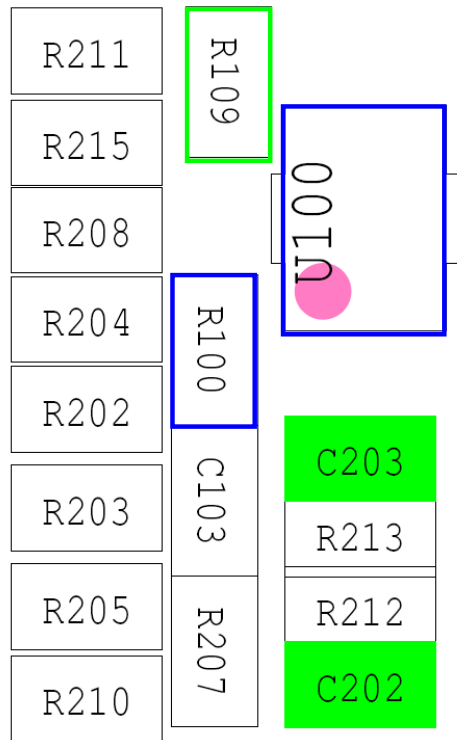

## 9-9. LCD part

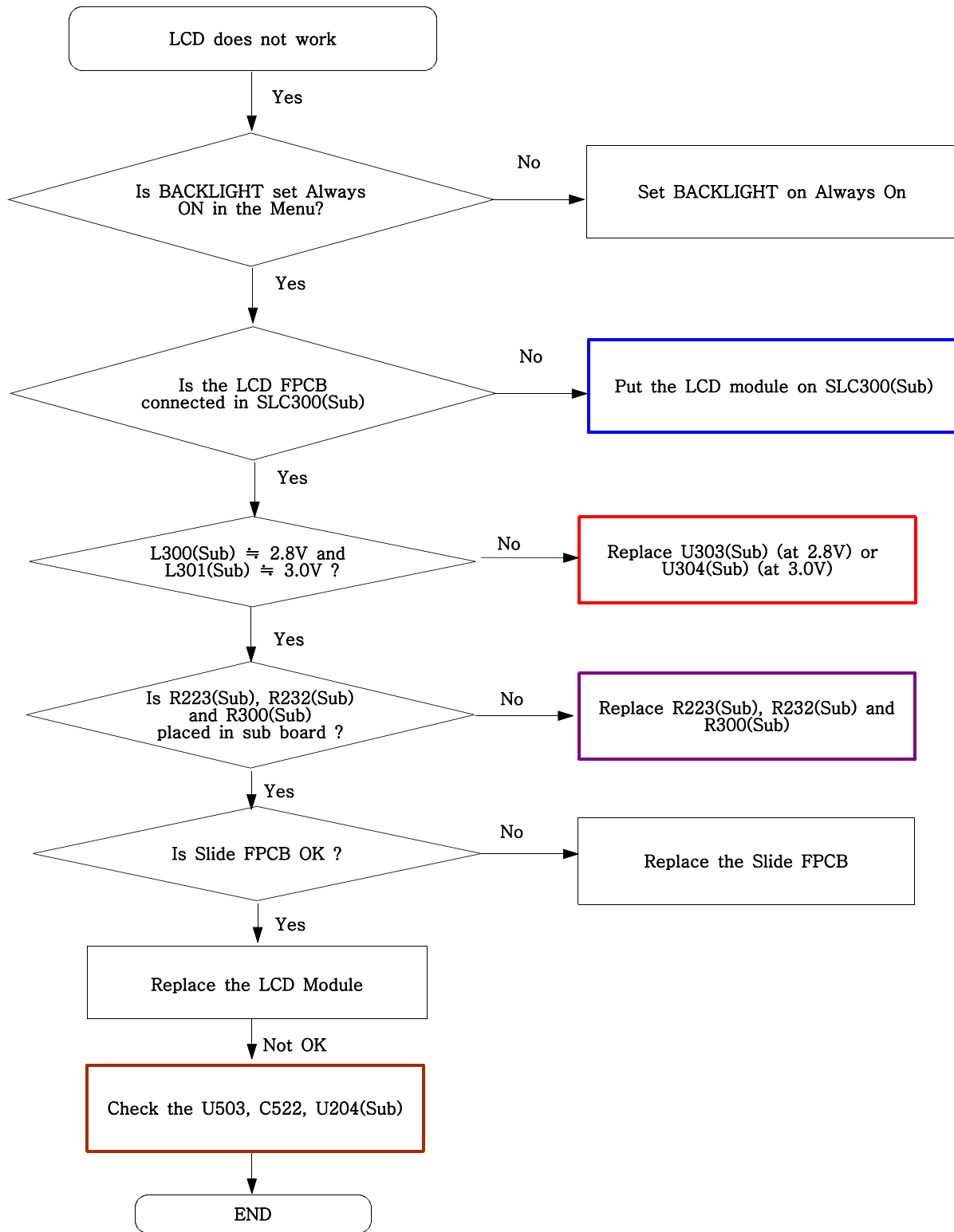

Flow Chart of Troubleshooting

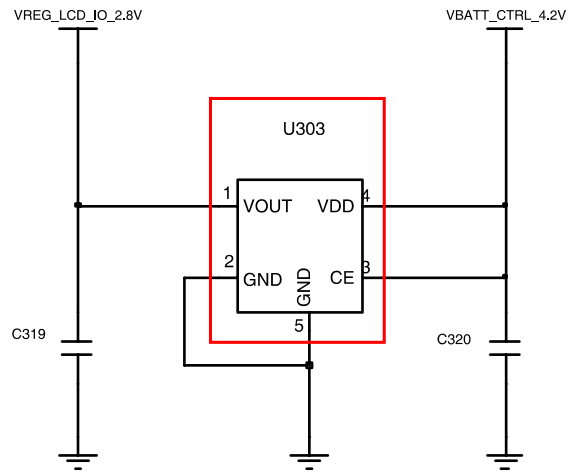
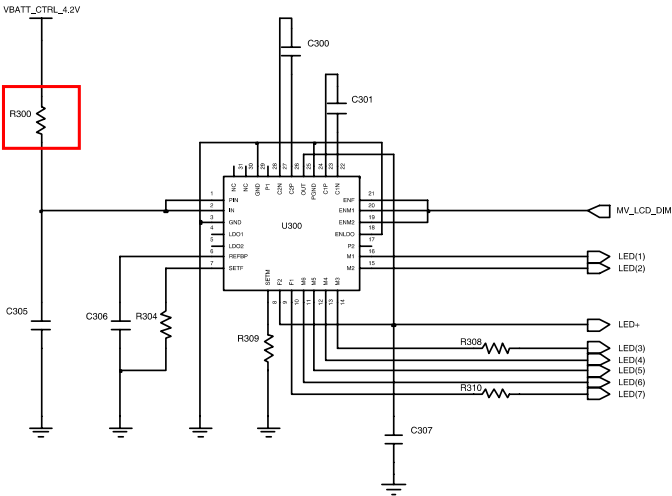
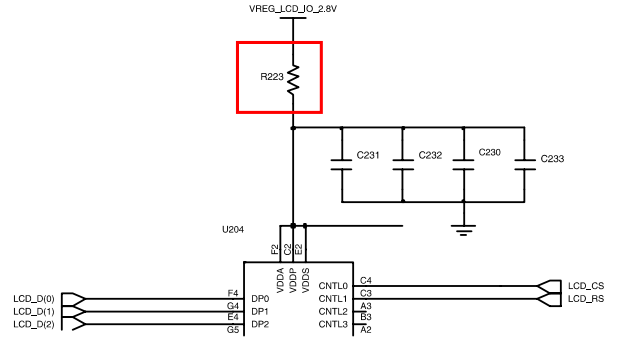
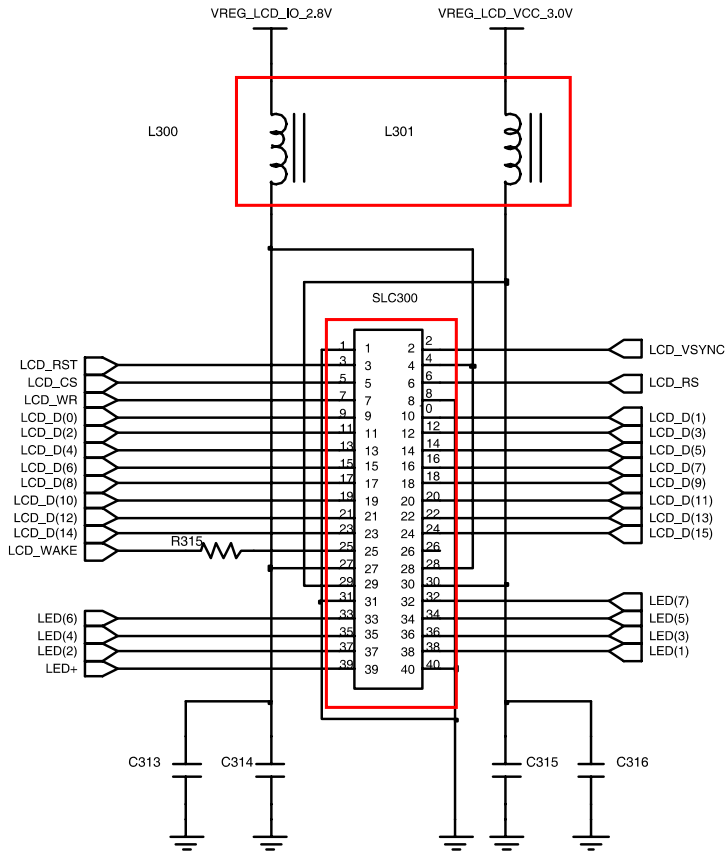

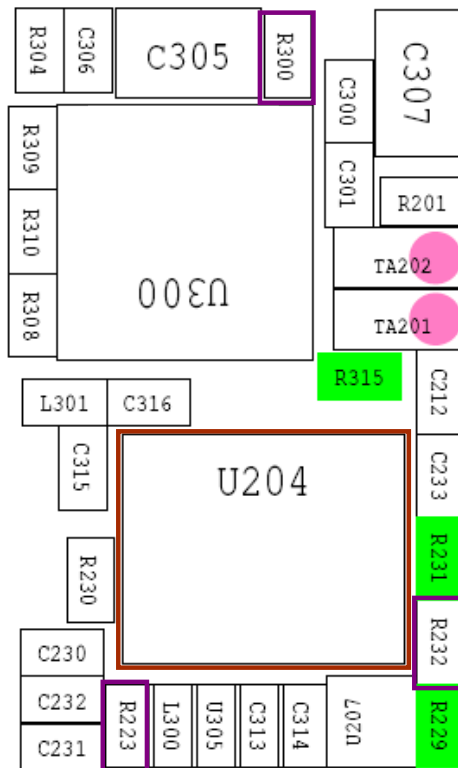
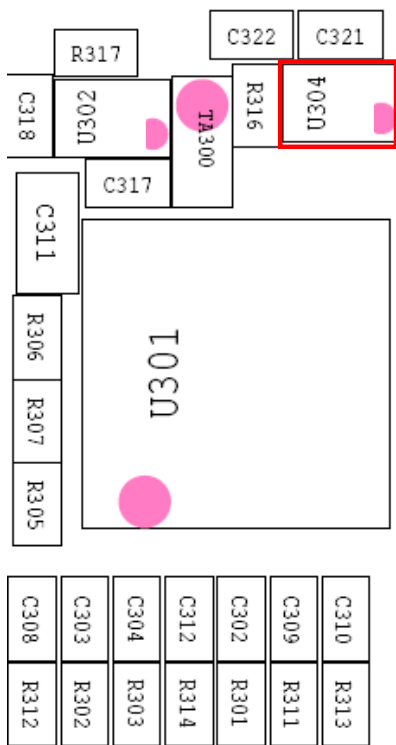
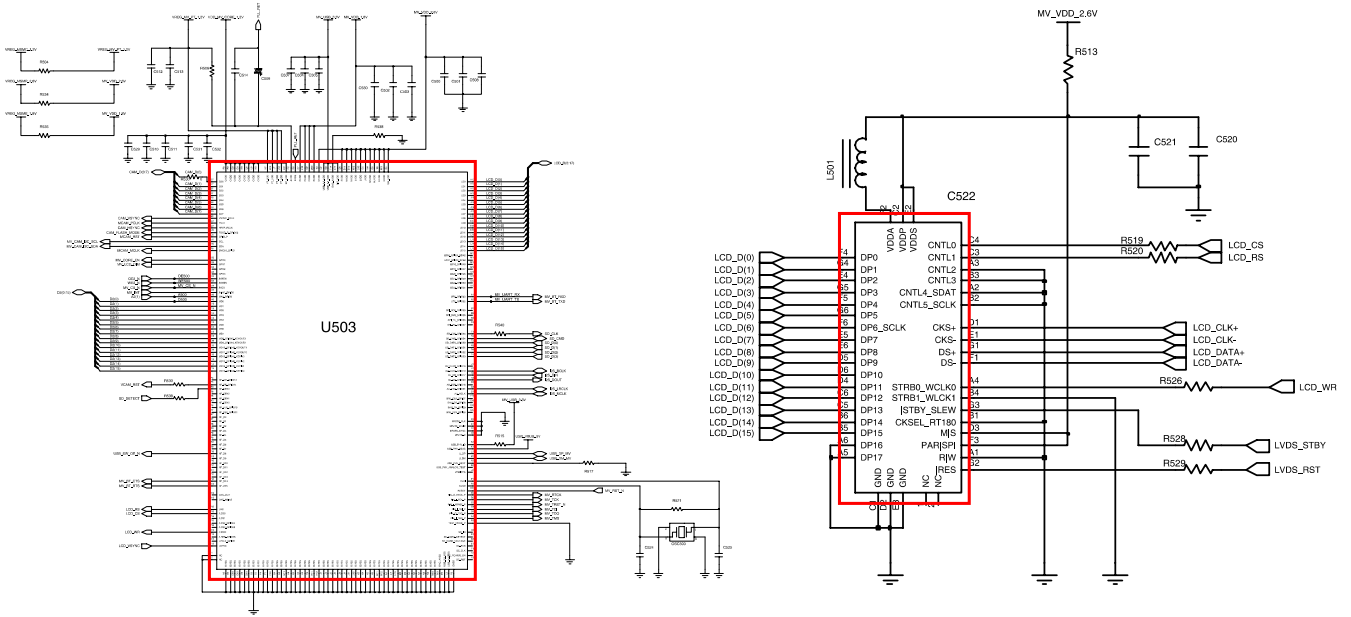

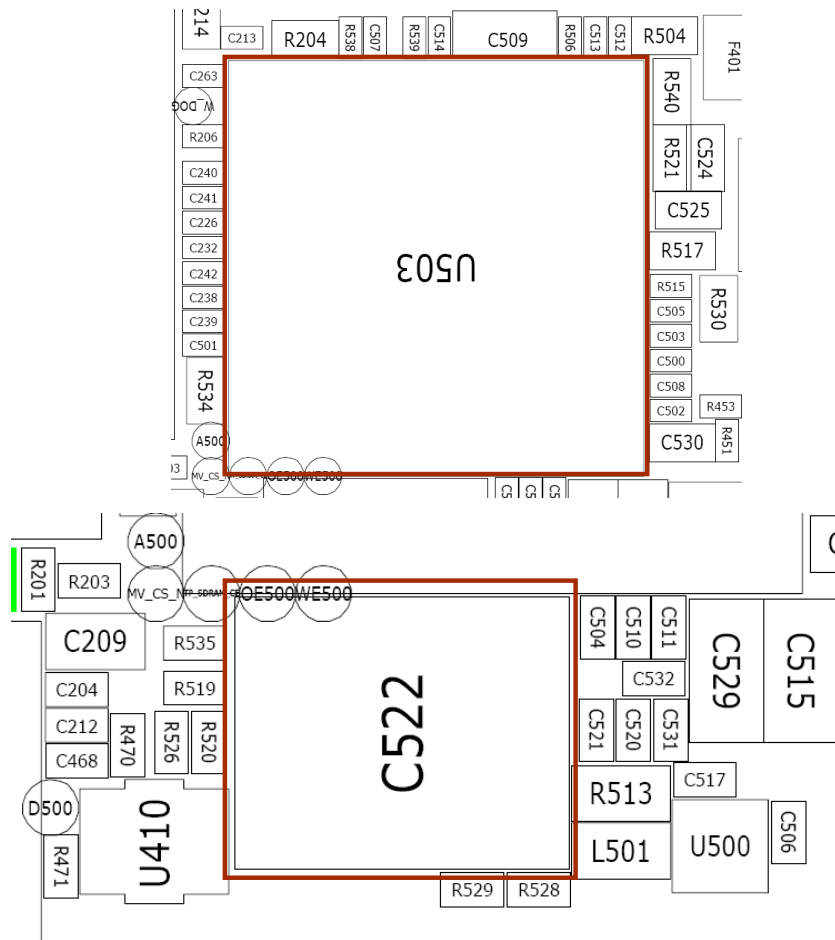

## 9-10. Key Back Light

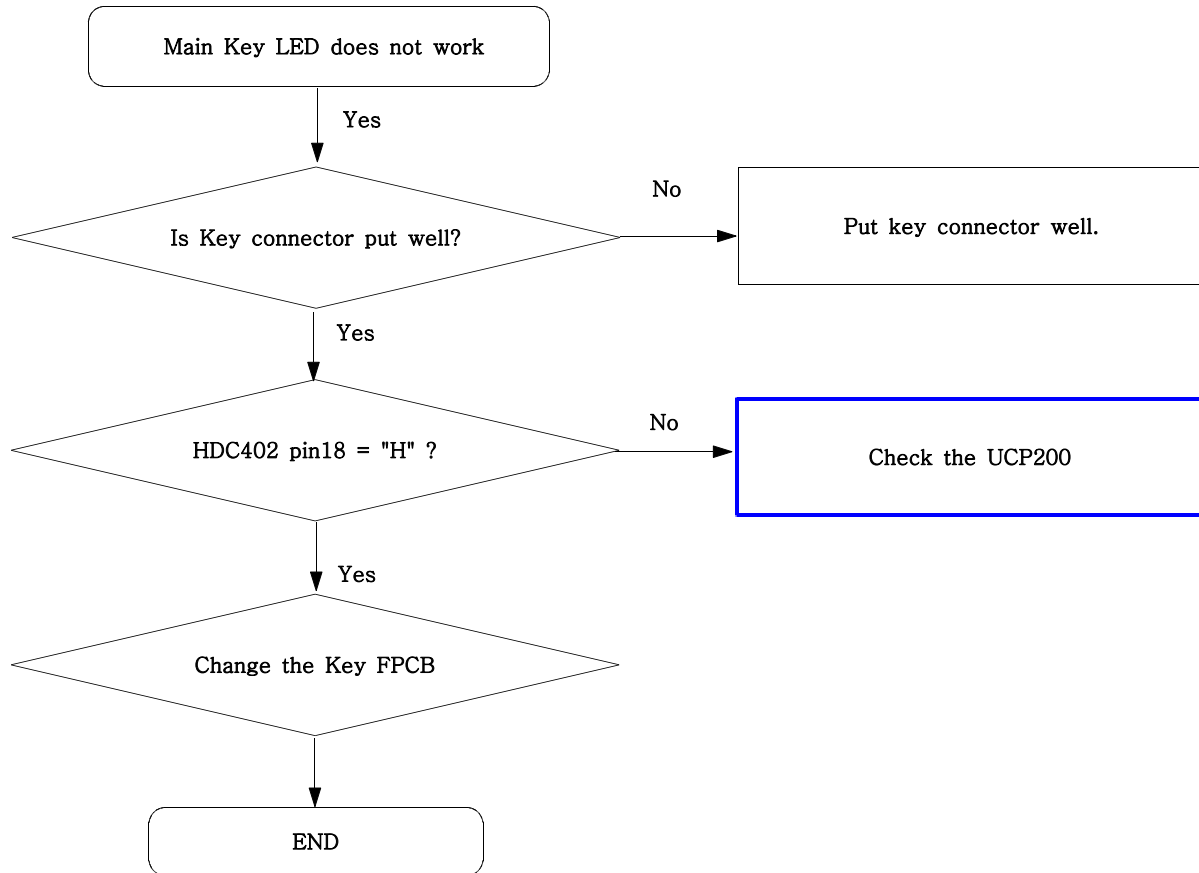

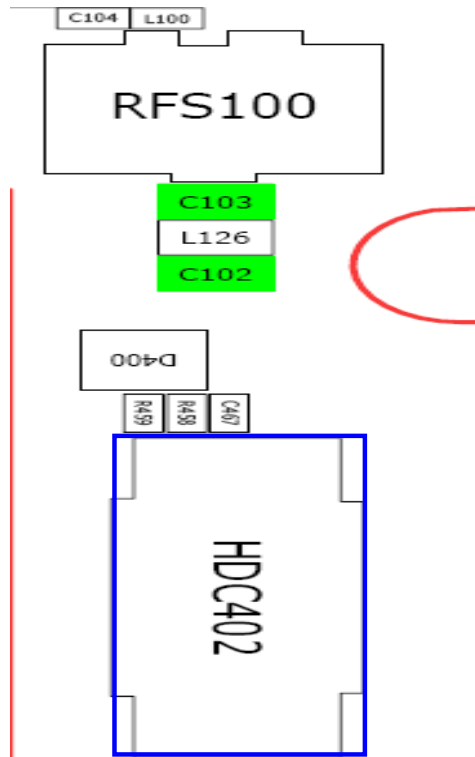
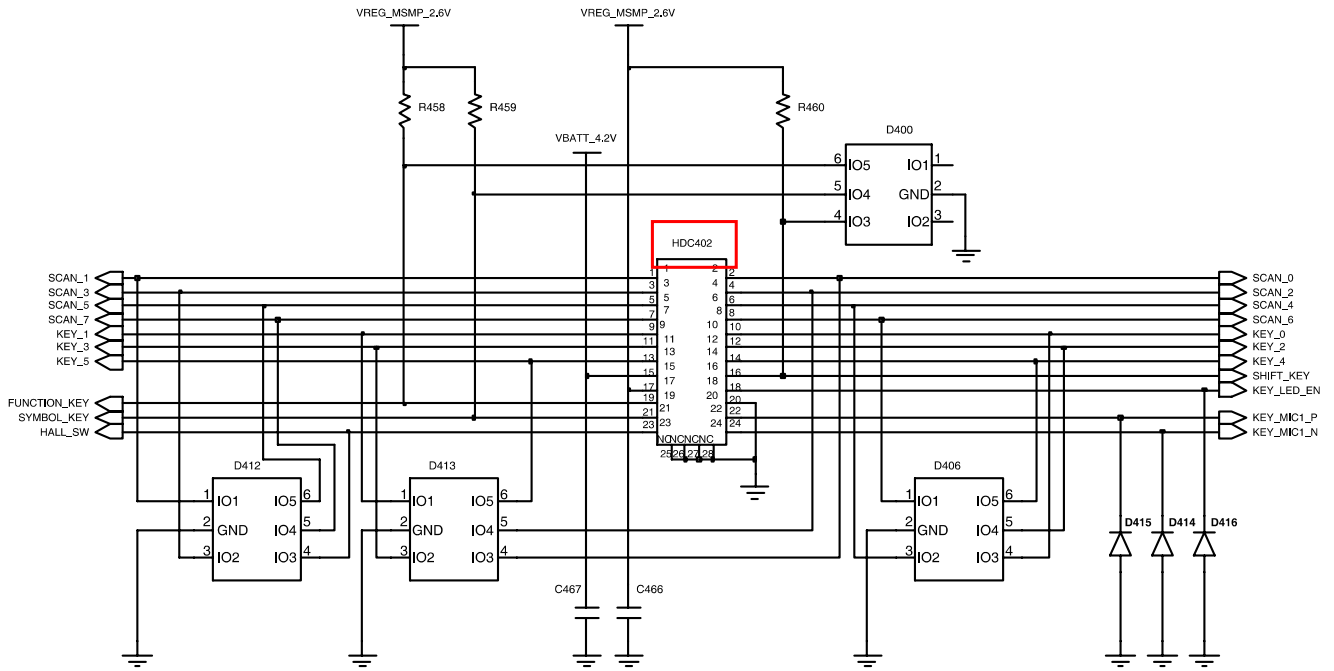

9-11. Camera part ( 3 Mega )

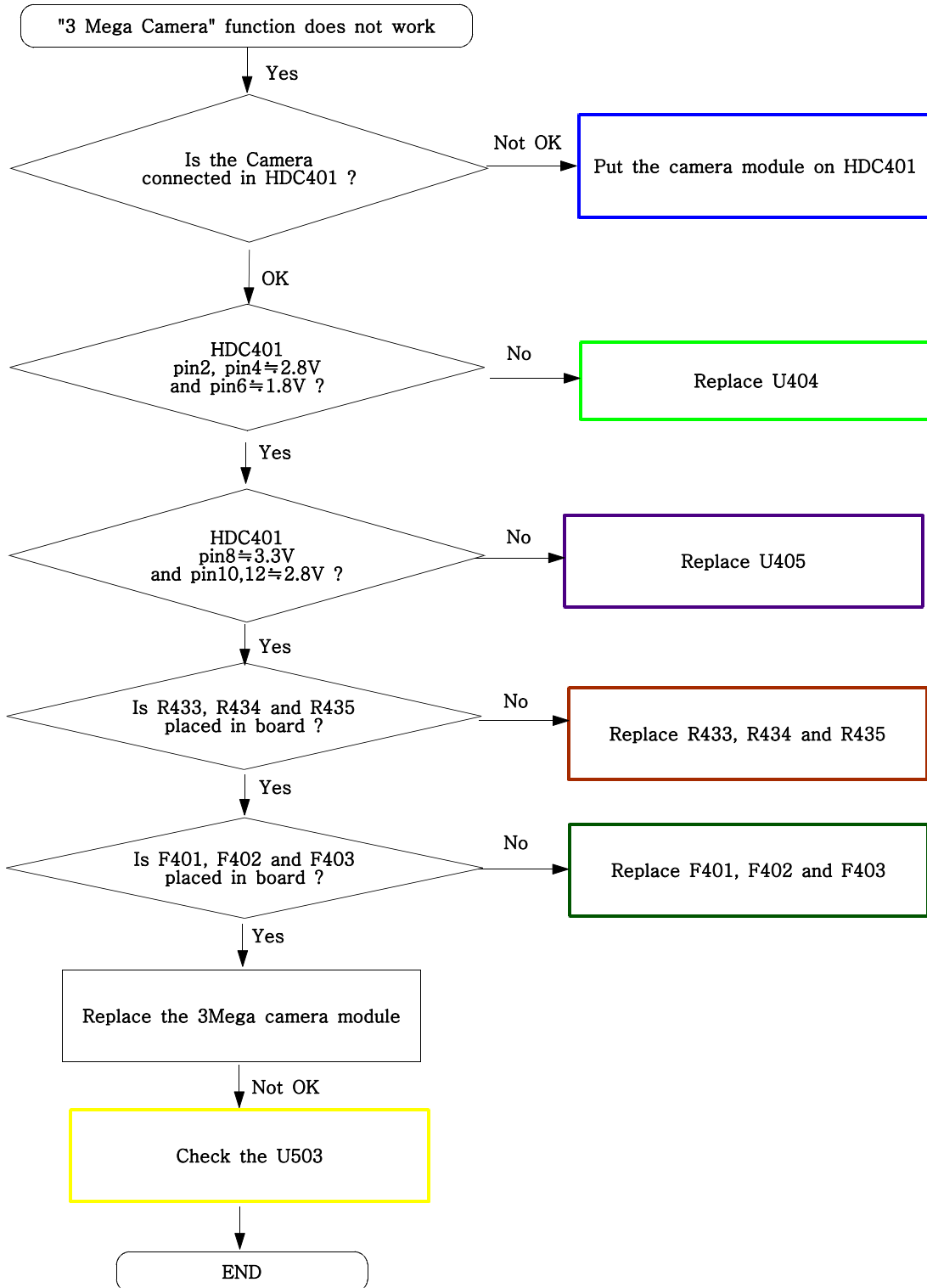

# Flow Chart of Troubleshooting

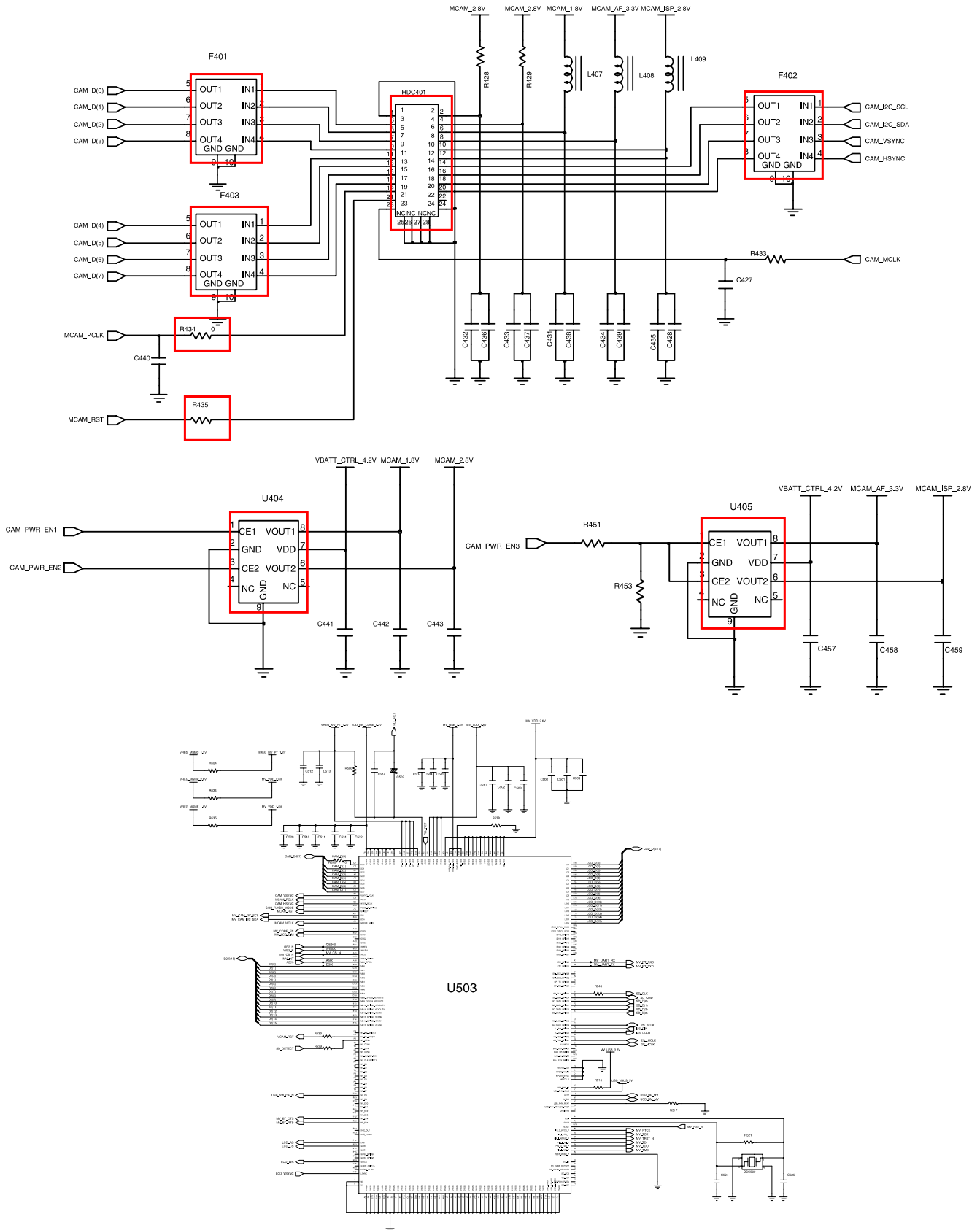

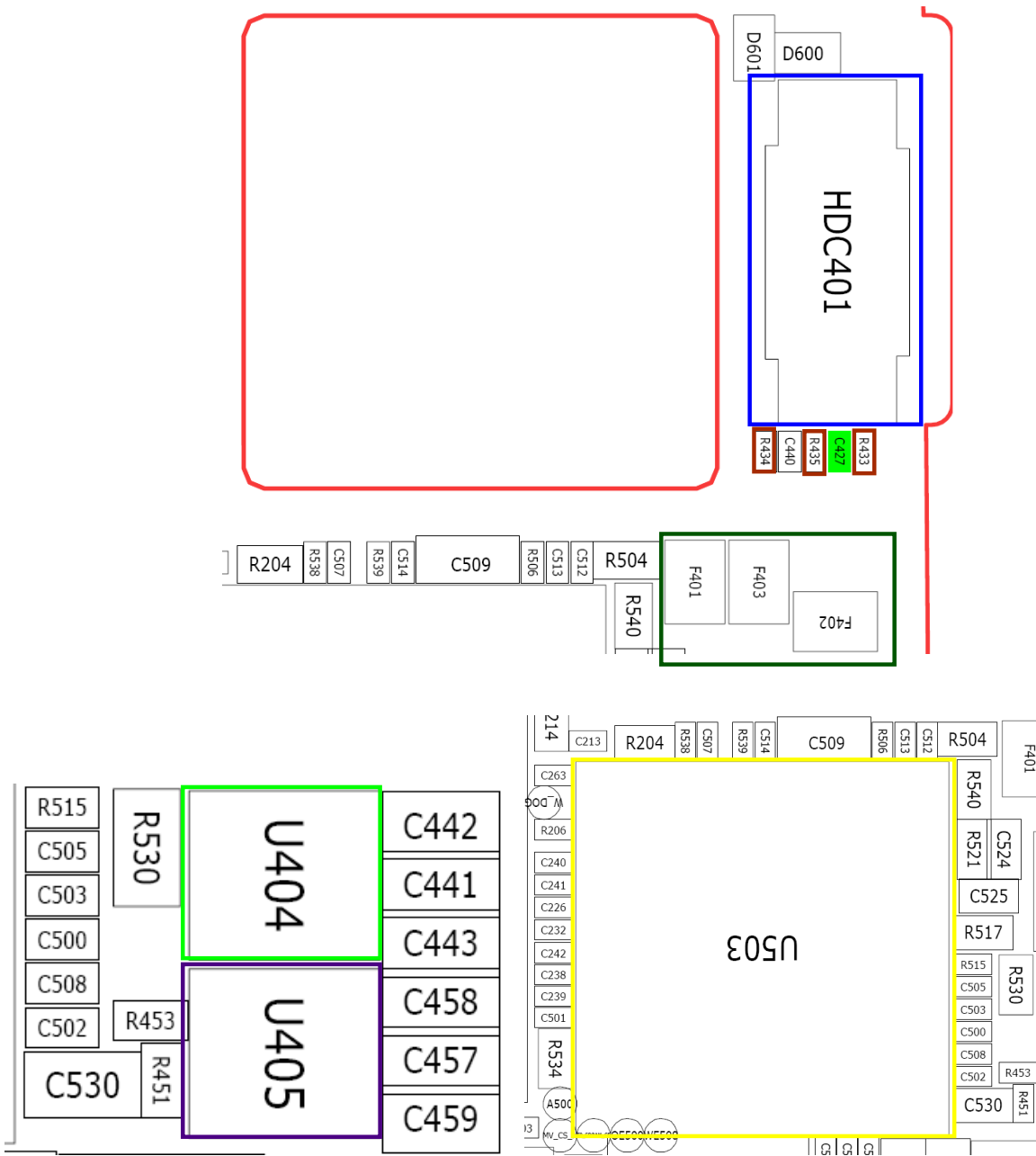

### 9-12. Camera part ( VGA )

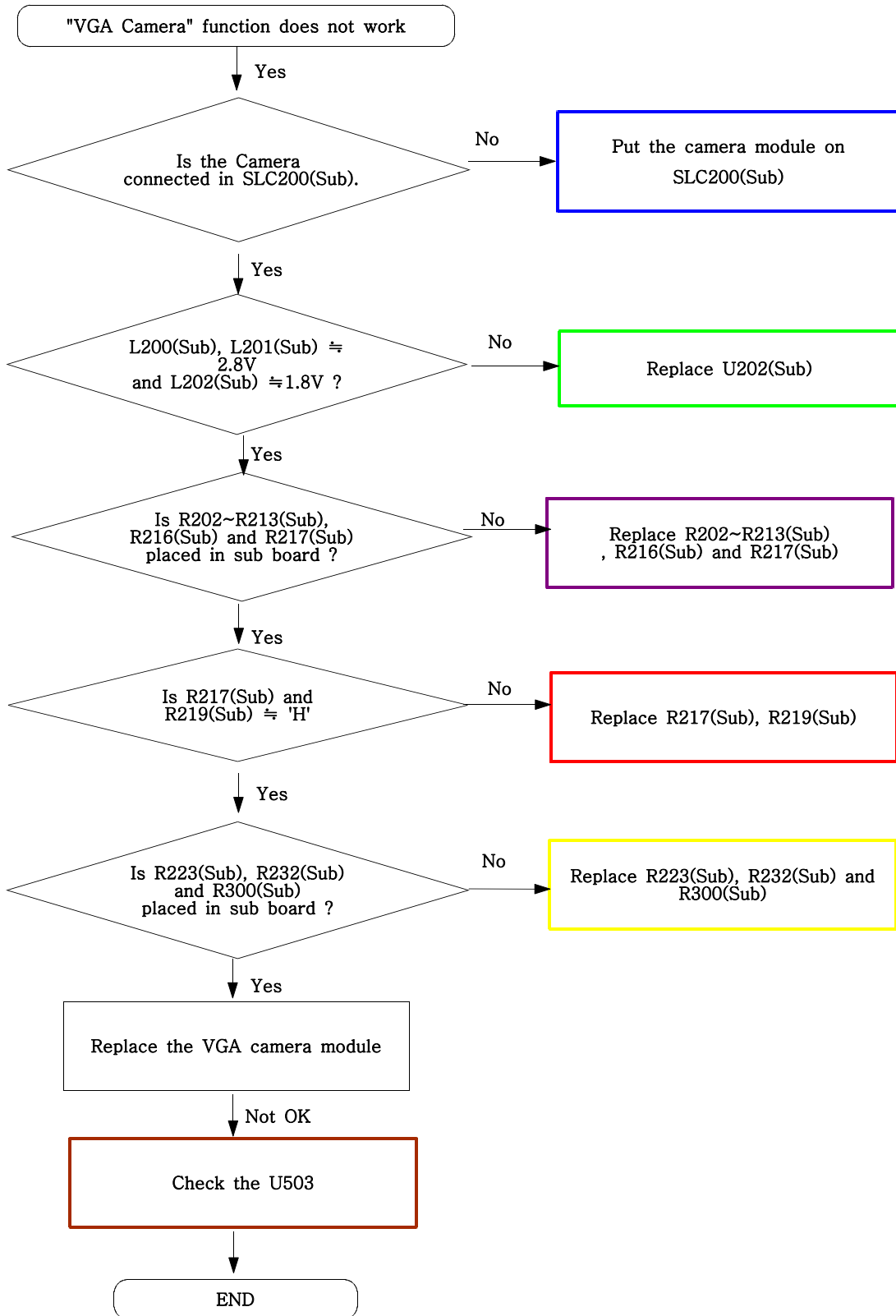

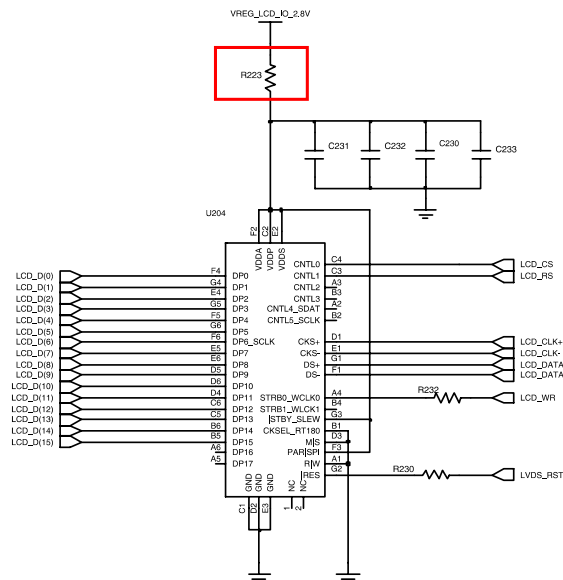
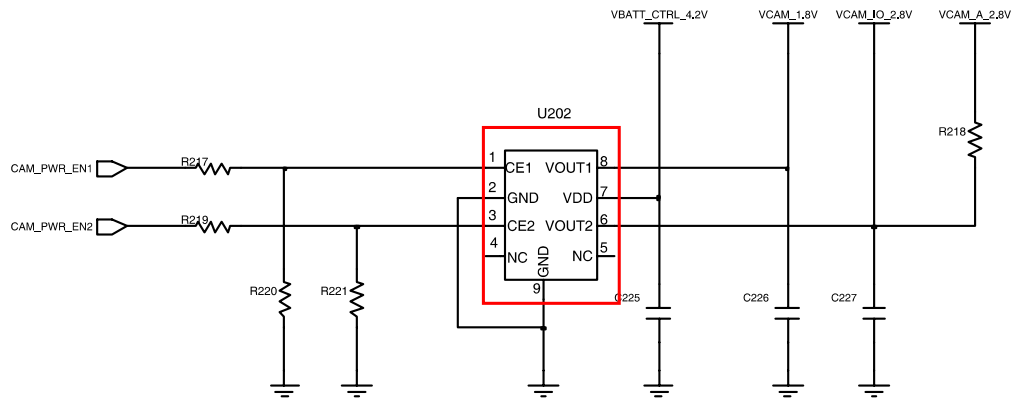
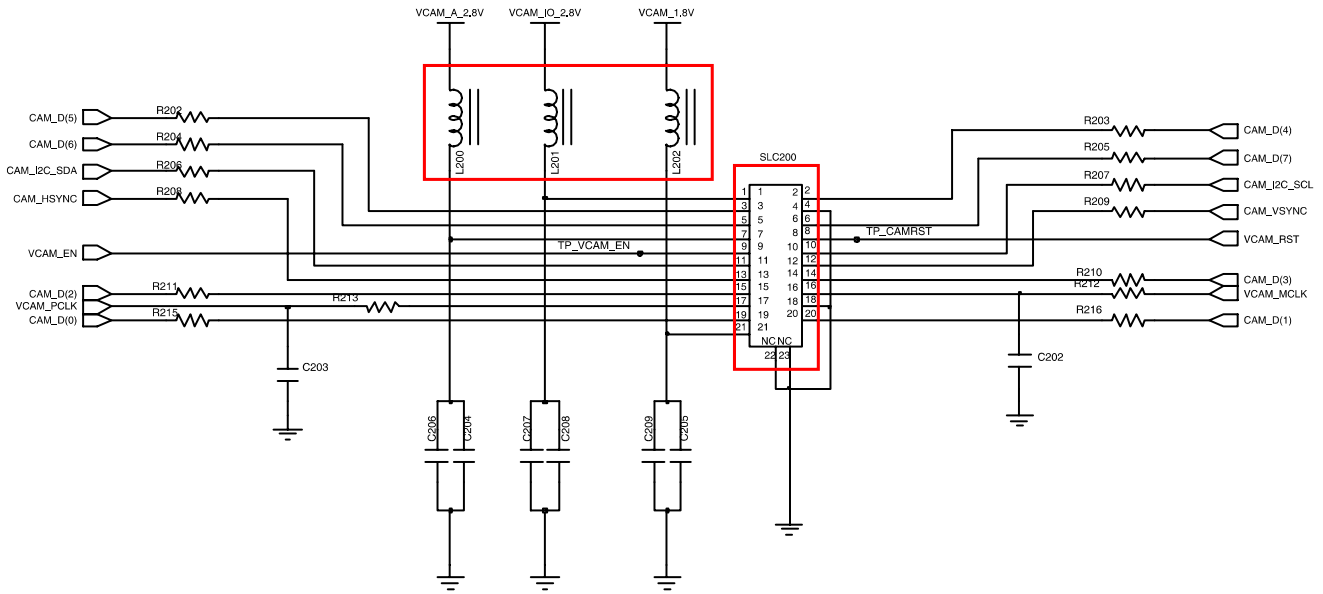



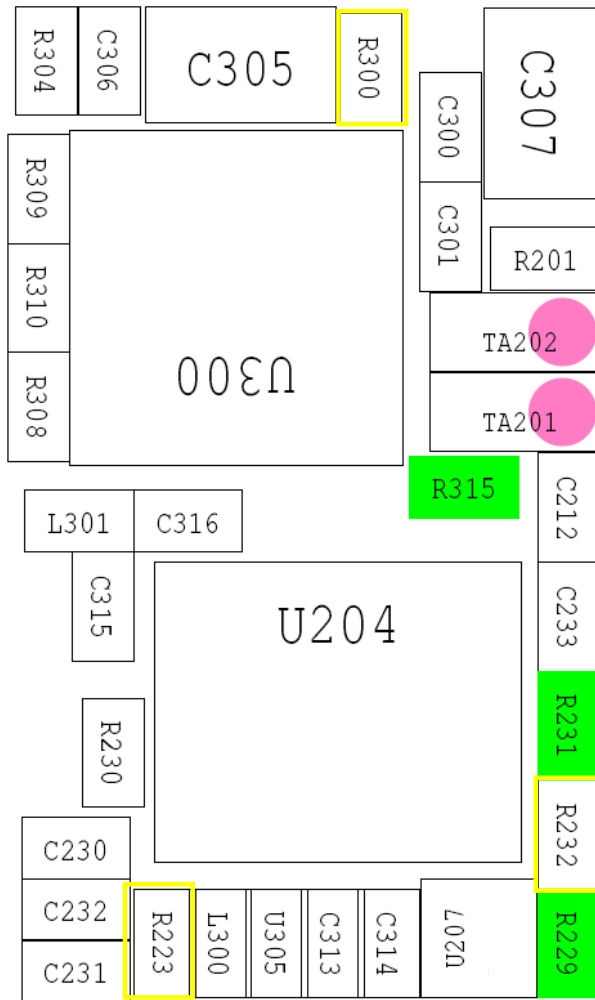

9-13. GSM Receiver

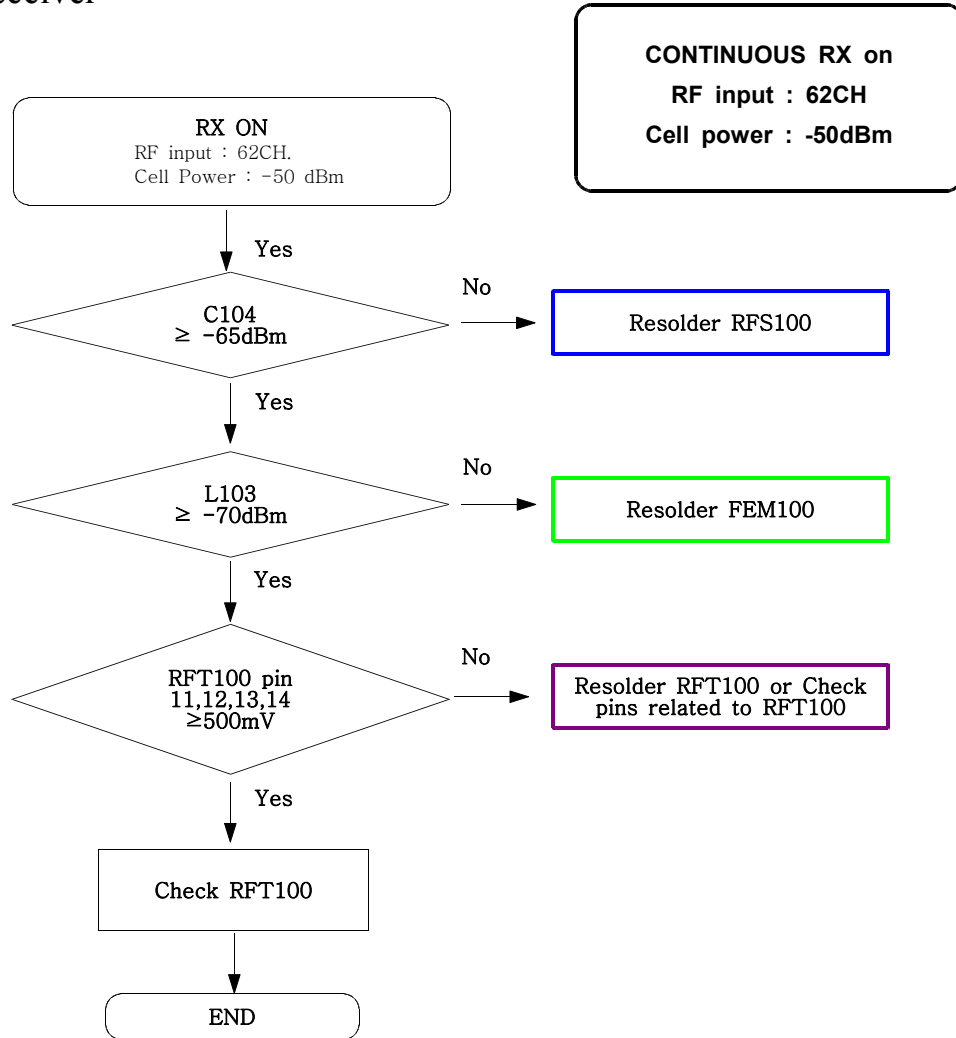

**CONTINUOUS RX on**  
**RF input : 62CH**  
**Cell power : -50dBm**

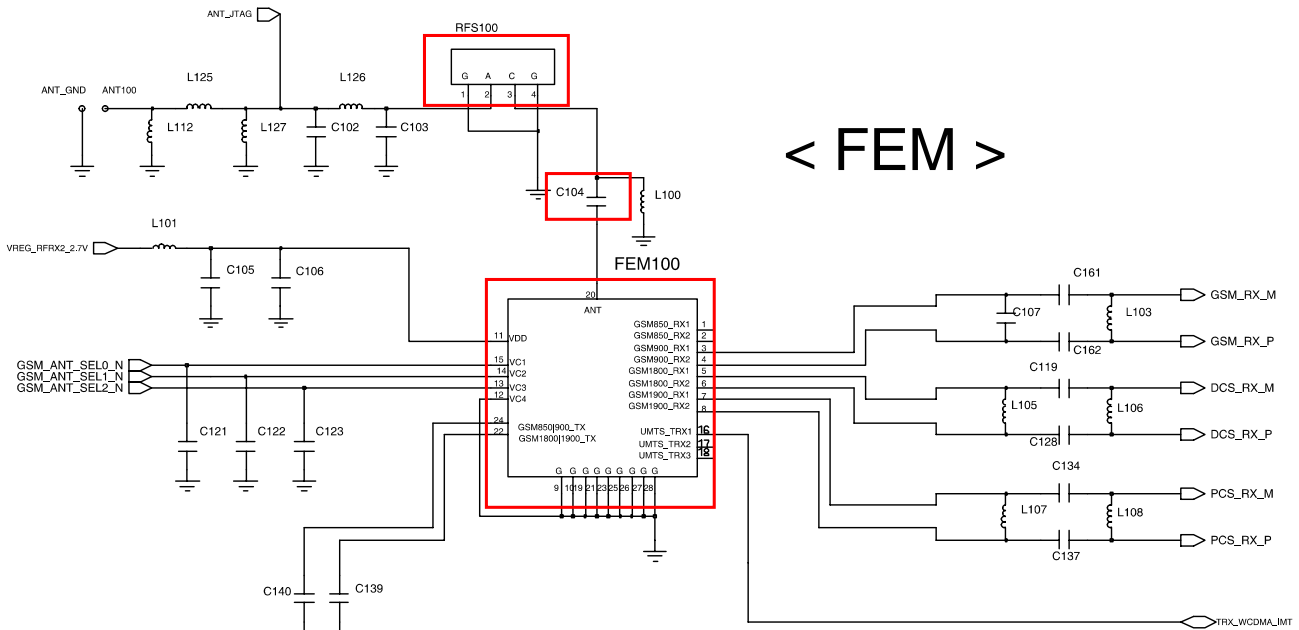



9-14. GSM Transmitter

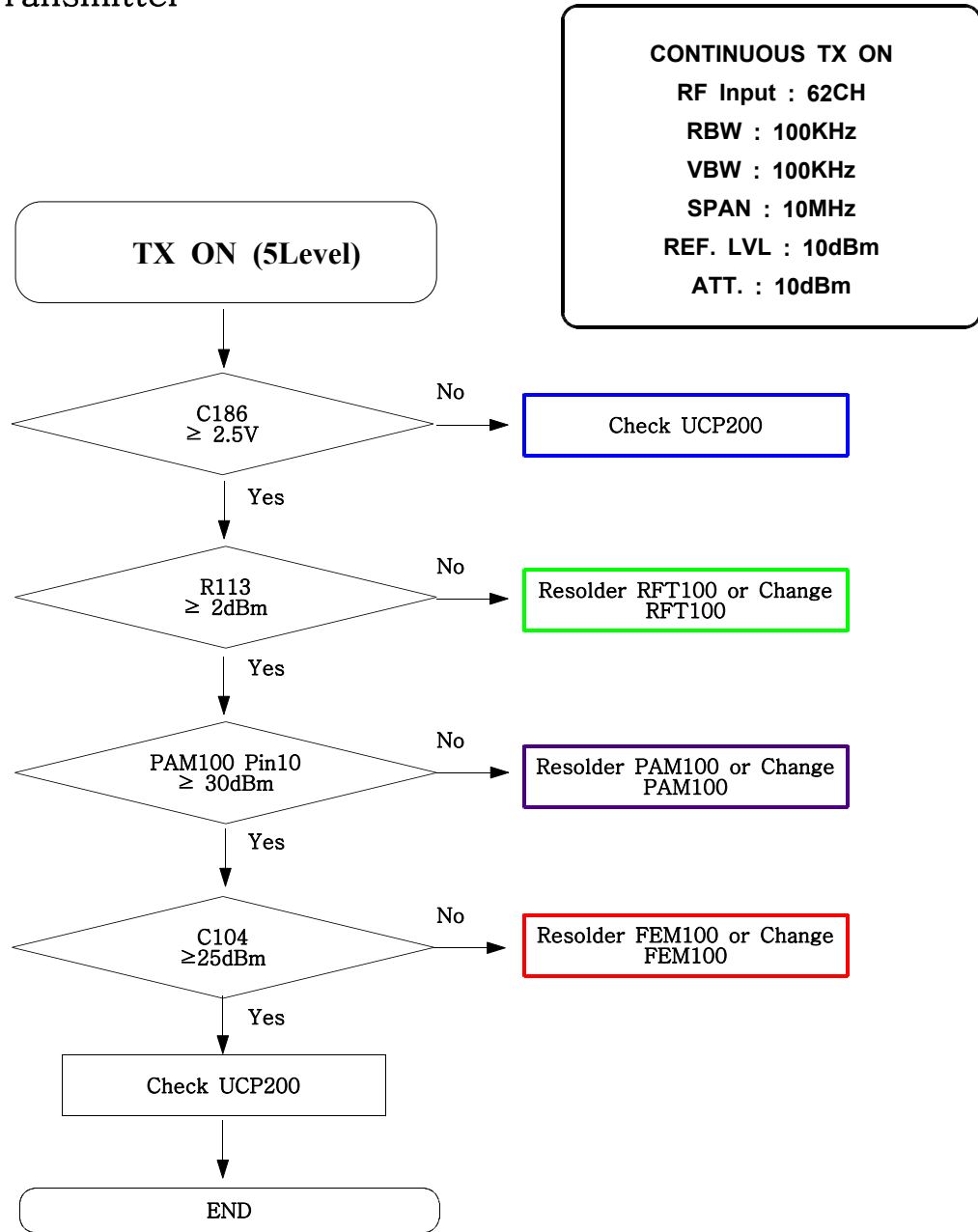

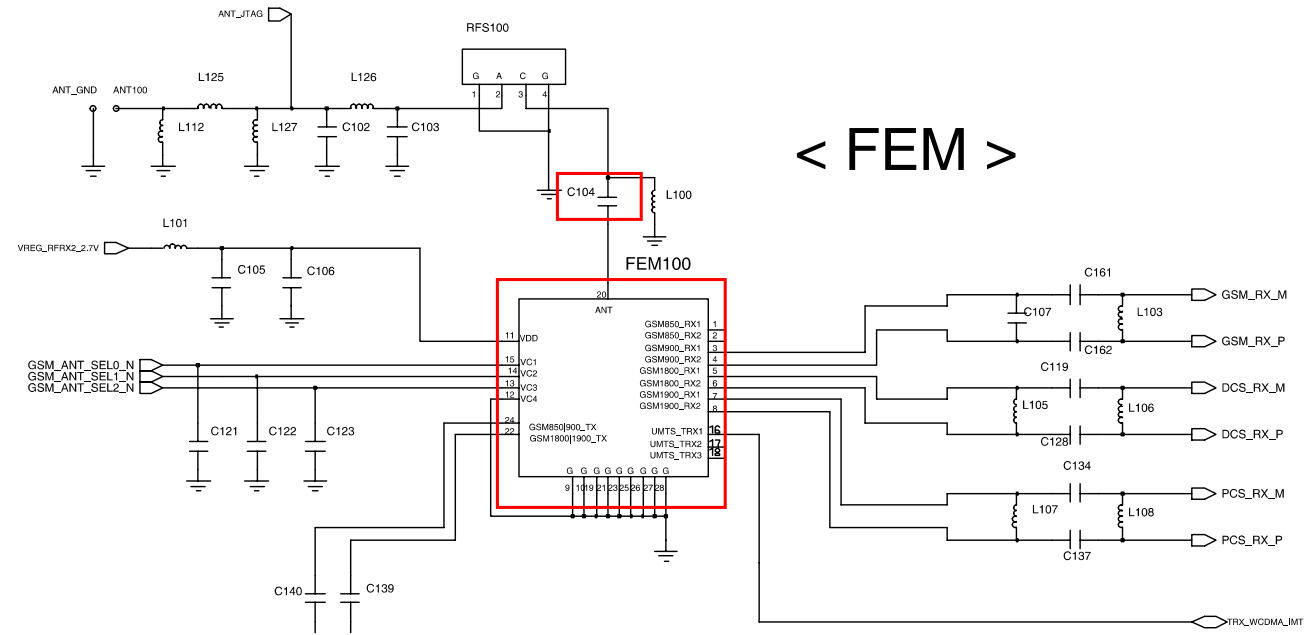
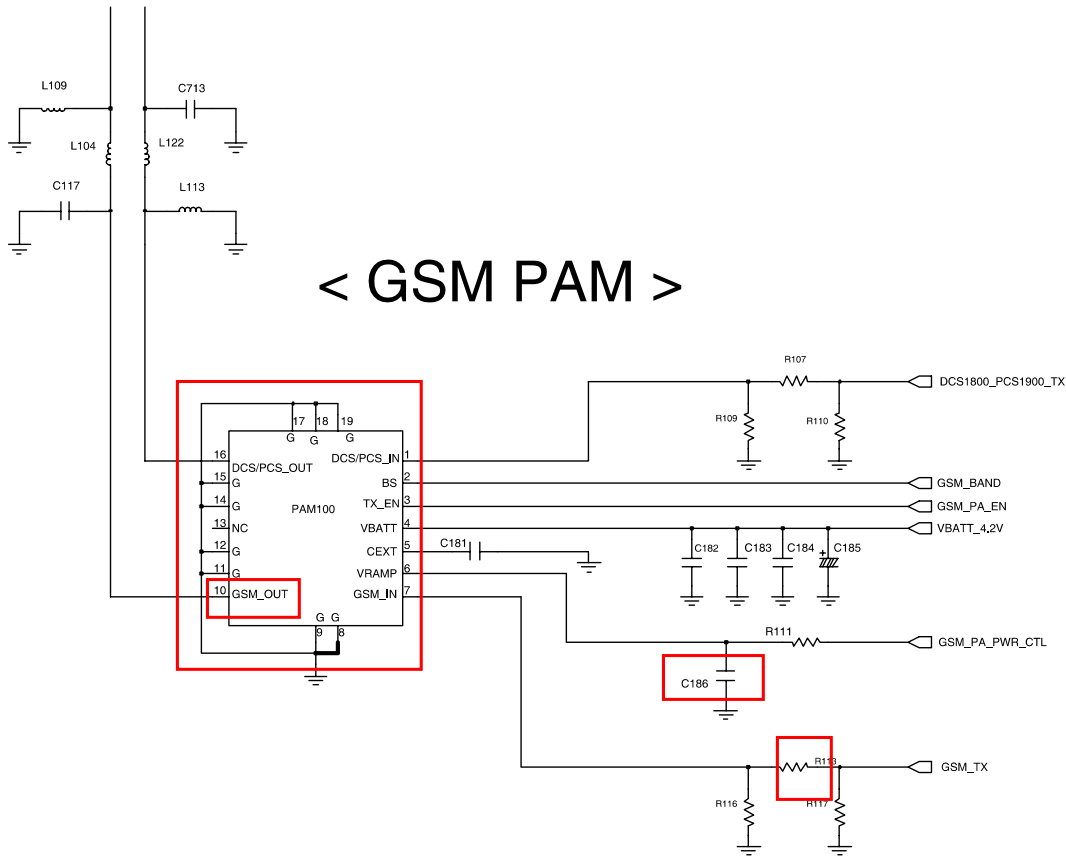

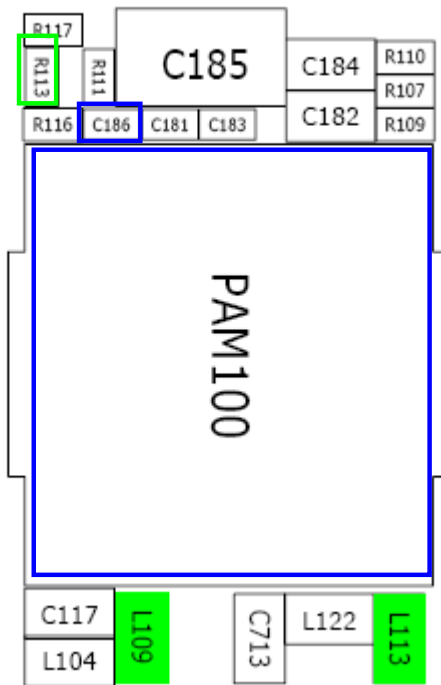
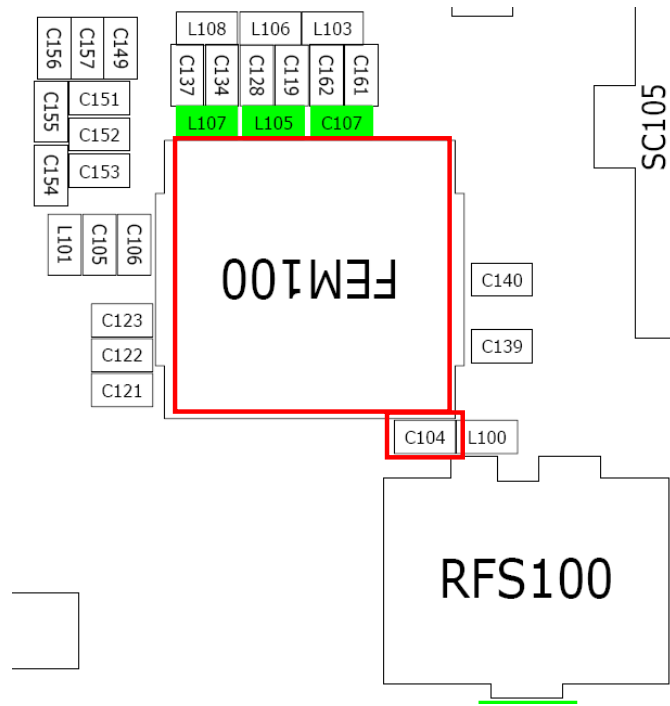

9-15. DCS Receiver

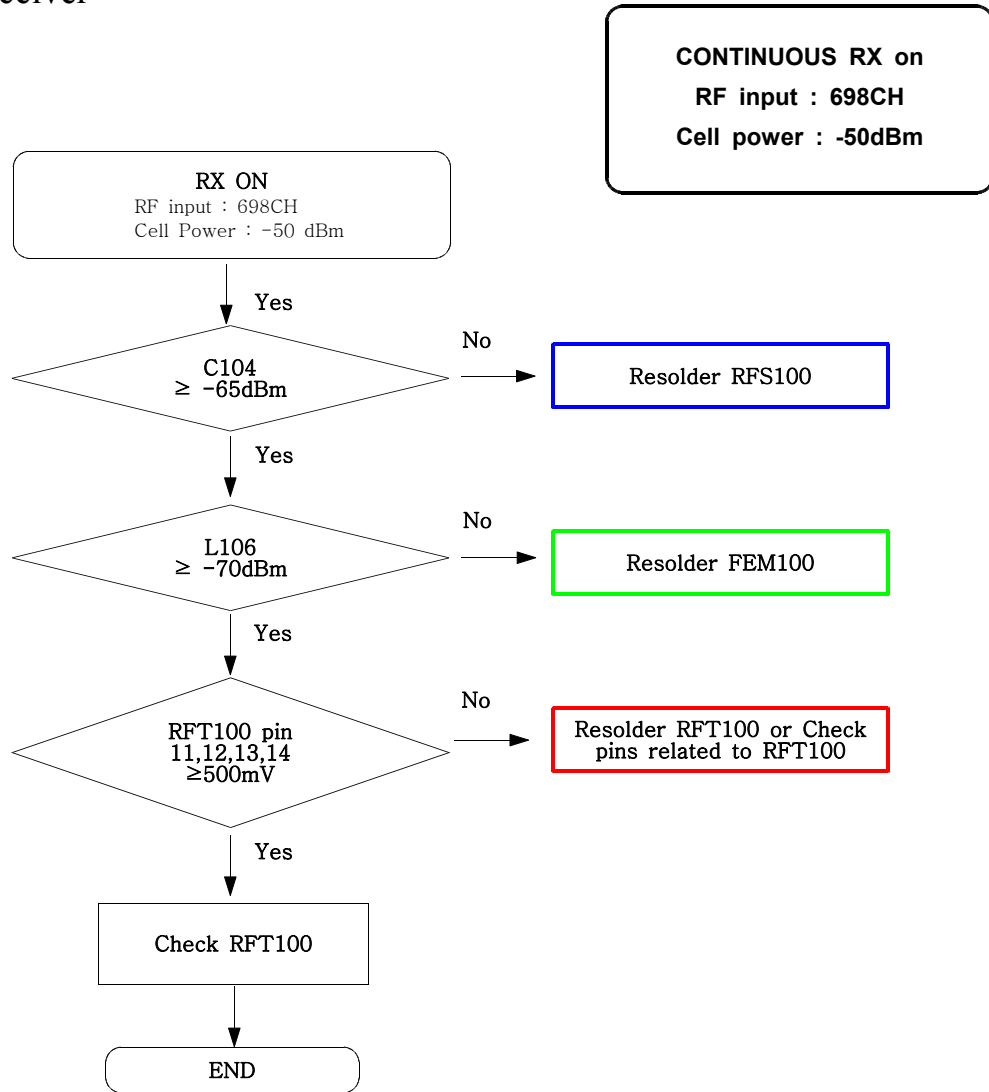





9-16. DCS Transmitter

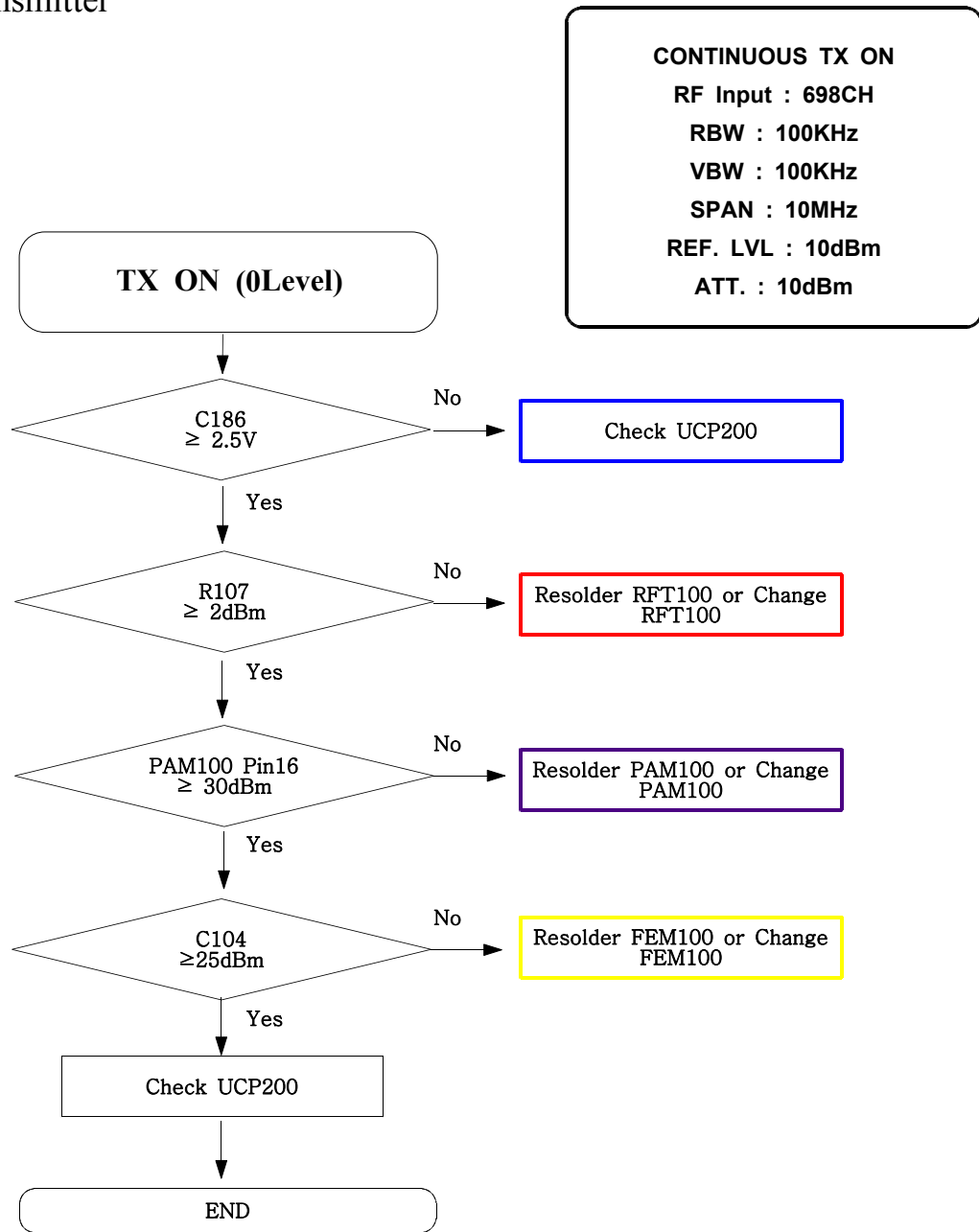

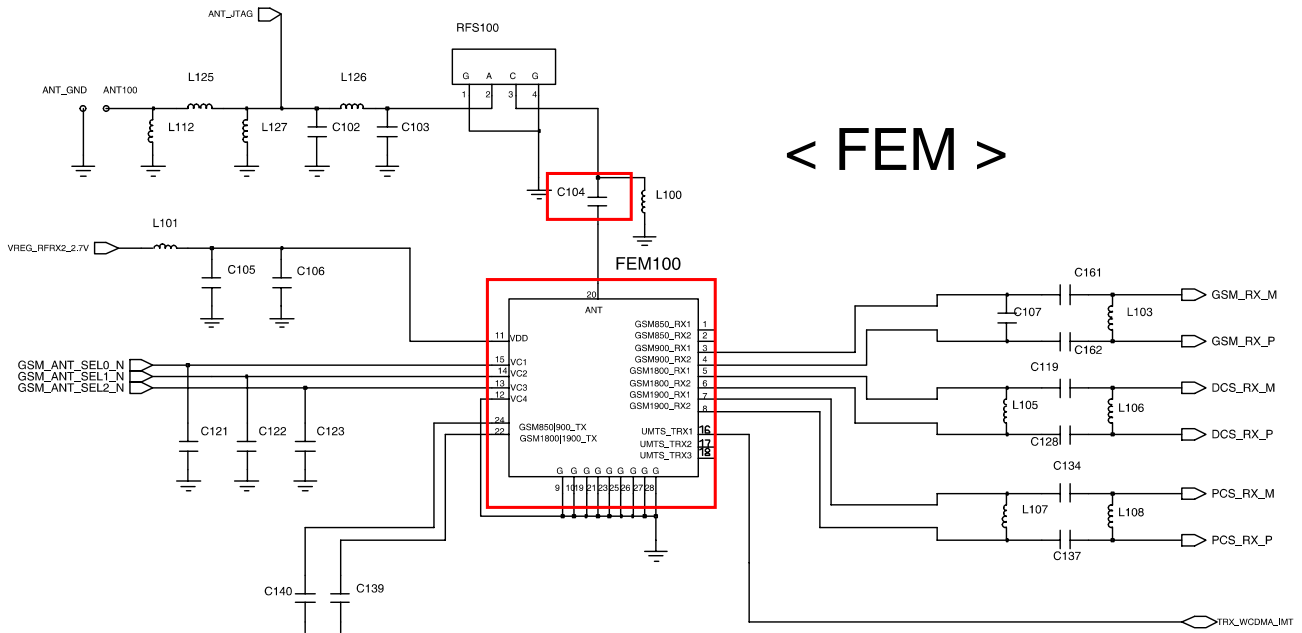
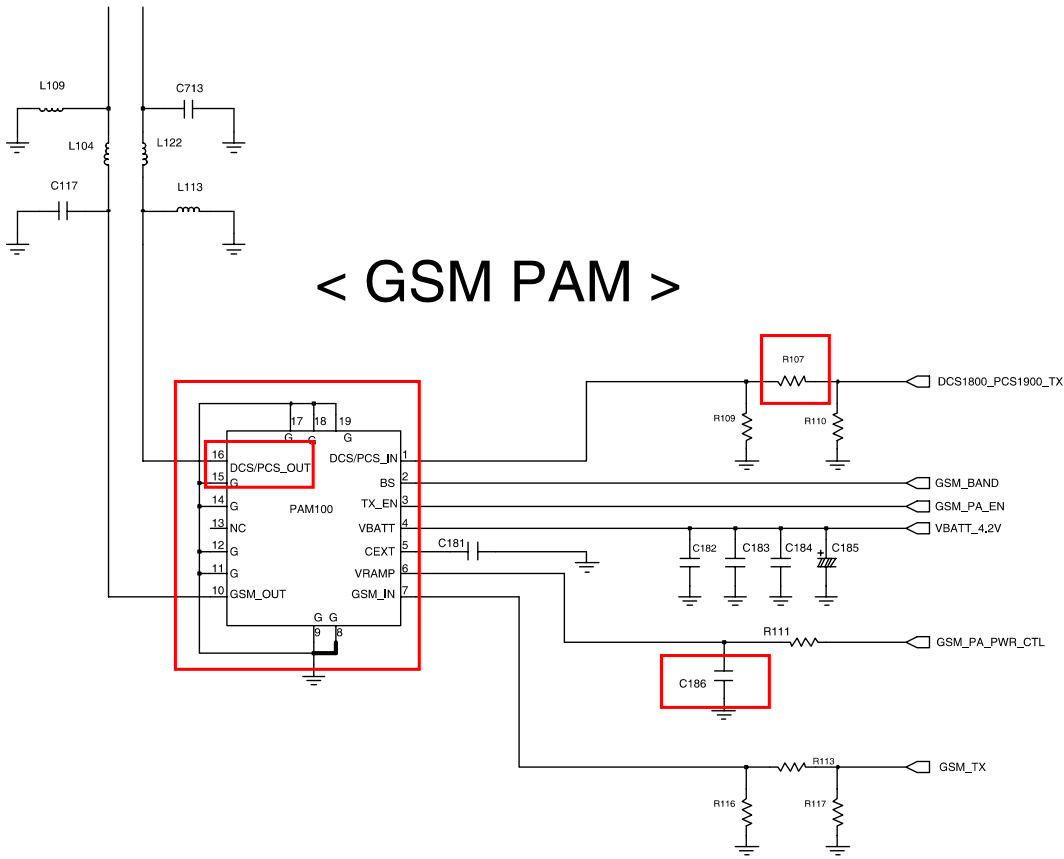

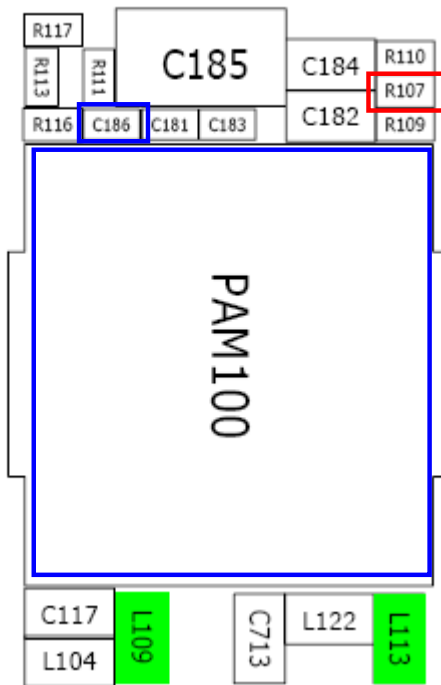
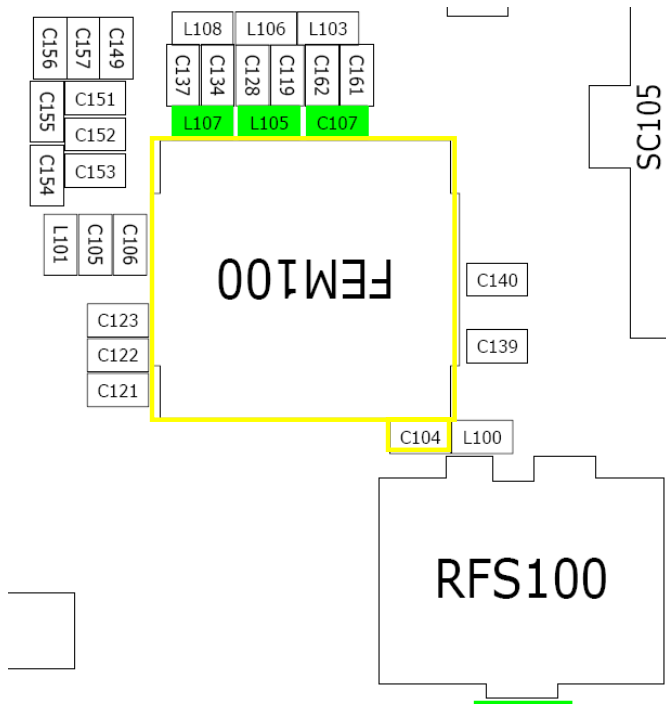

9-17. PCS Receiver

**CONTINUOUS RX on**  
**RF input : 698CH**  
**Cell power : -50dBm**

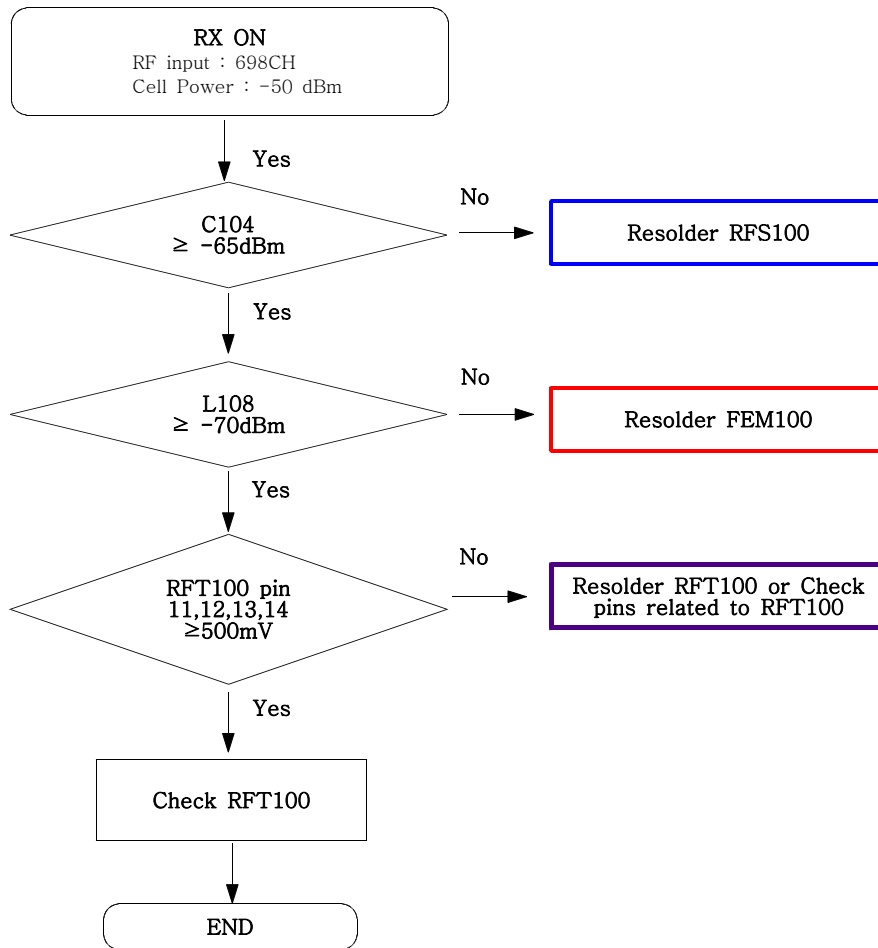





9-18. PCS Transmitter

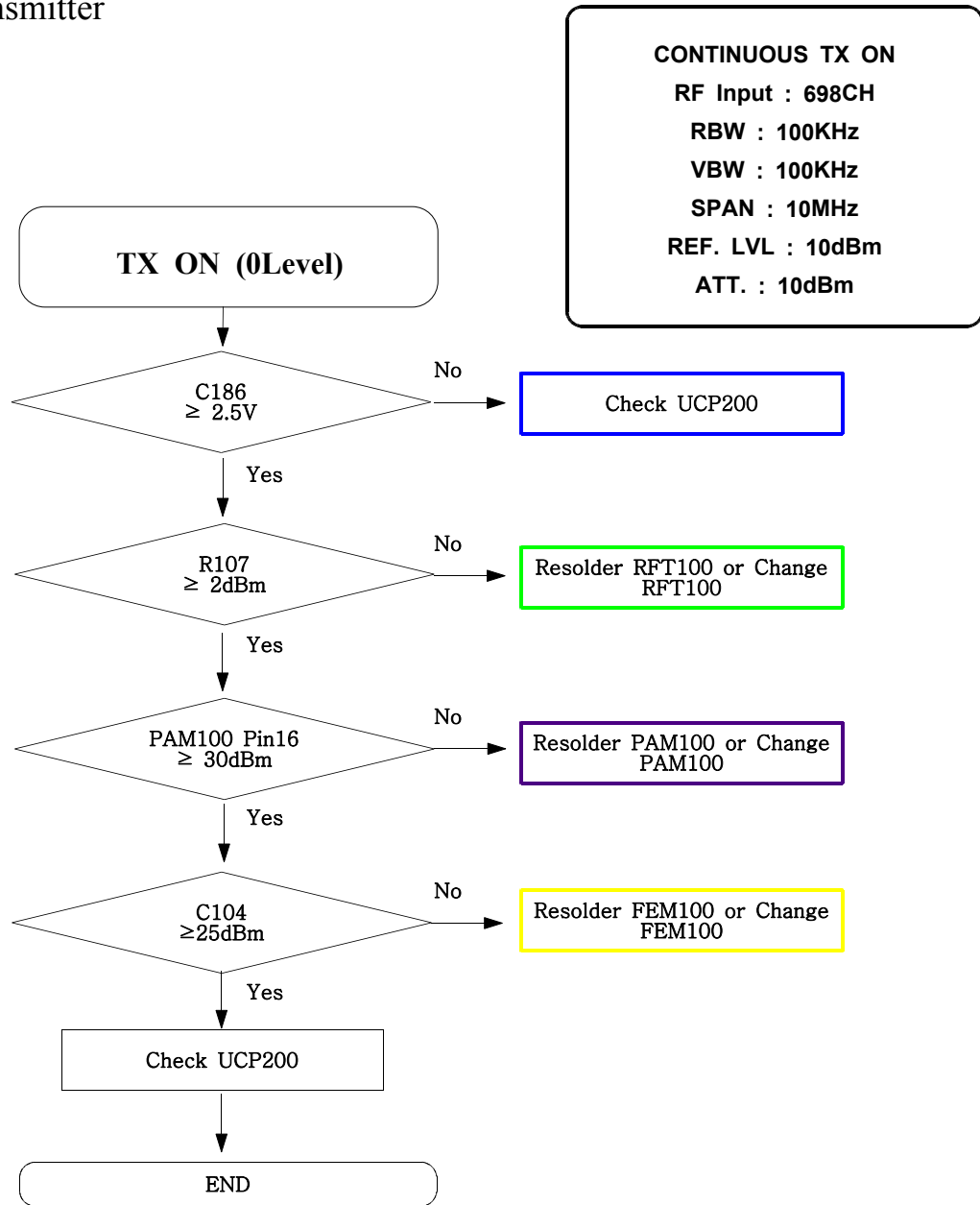

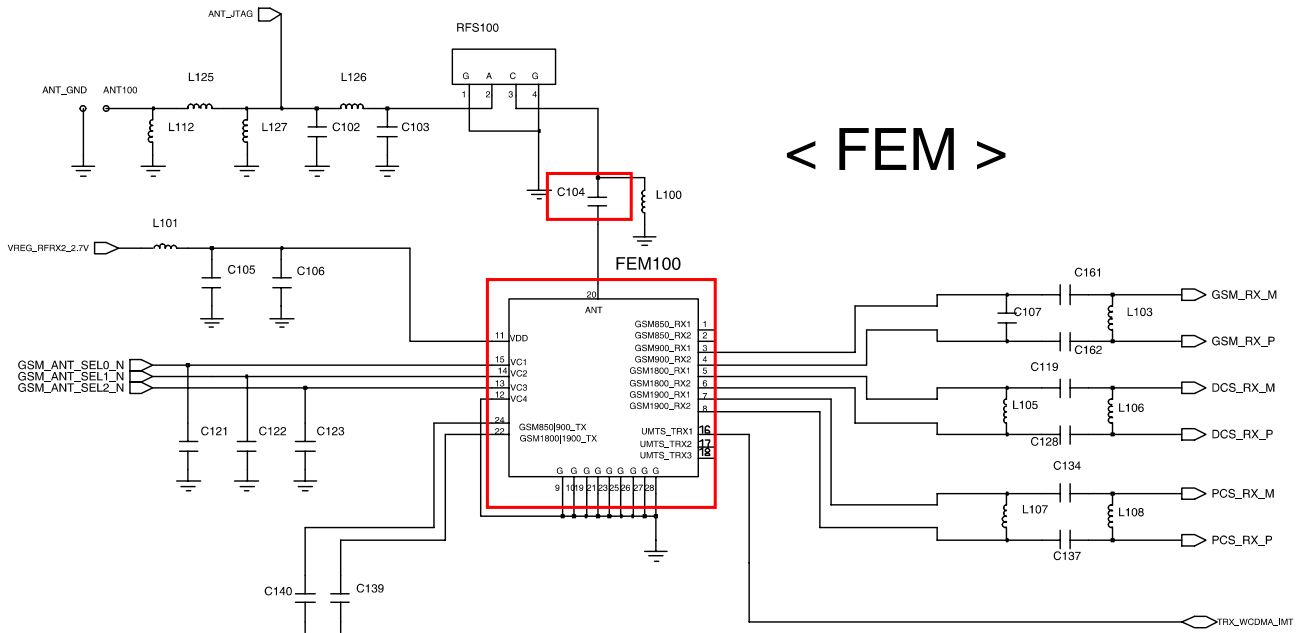
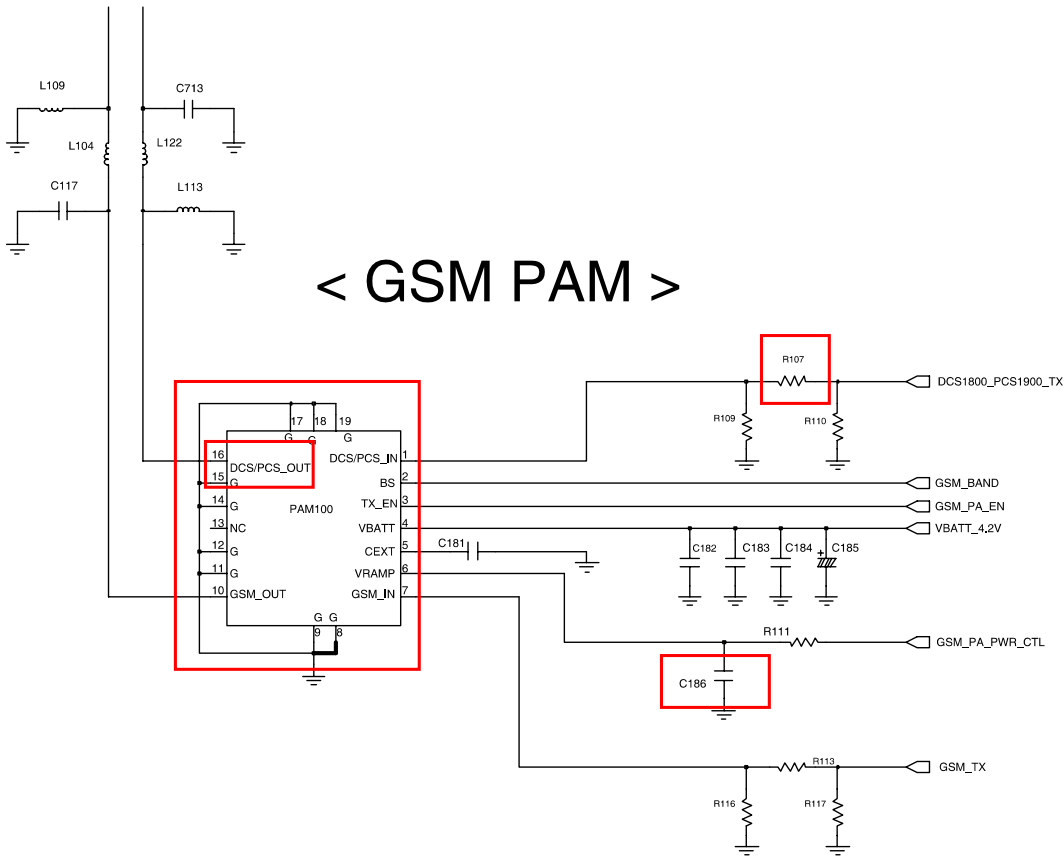

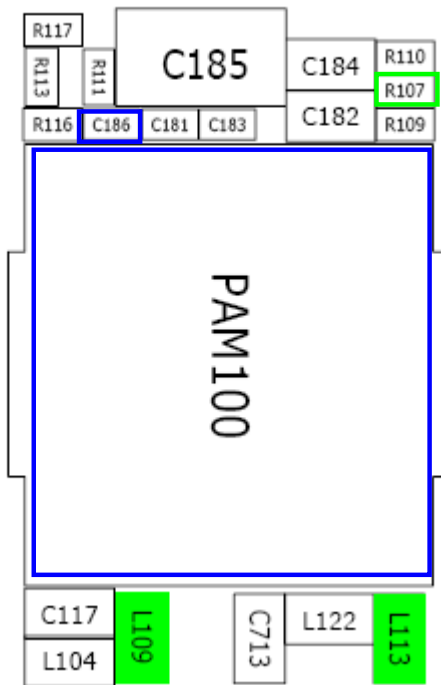
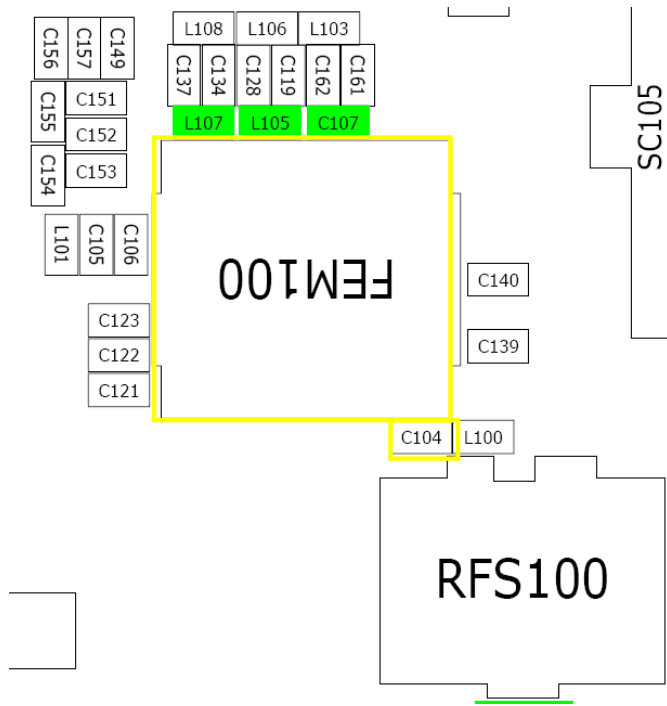

### 9-19. WCDMA Receiver

**CONTINUOUS RX on**  
**RF input : 10700CH**  
**Cell power : -50dBm**

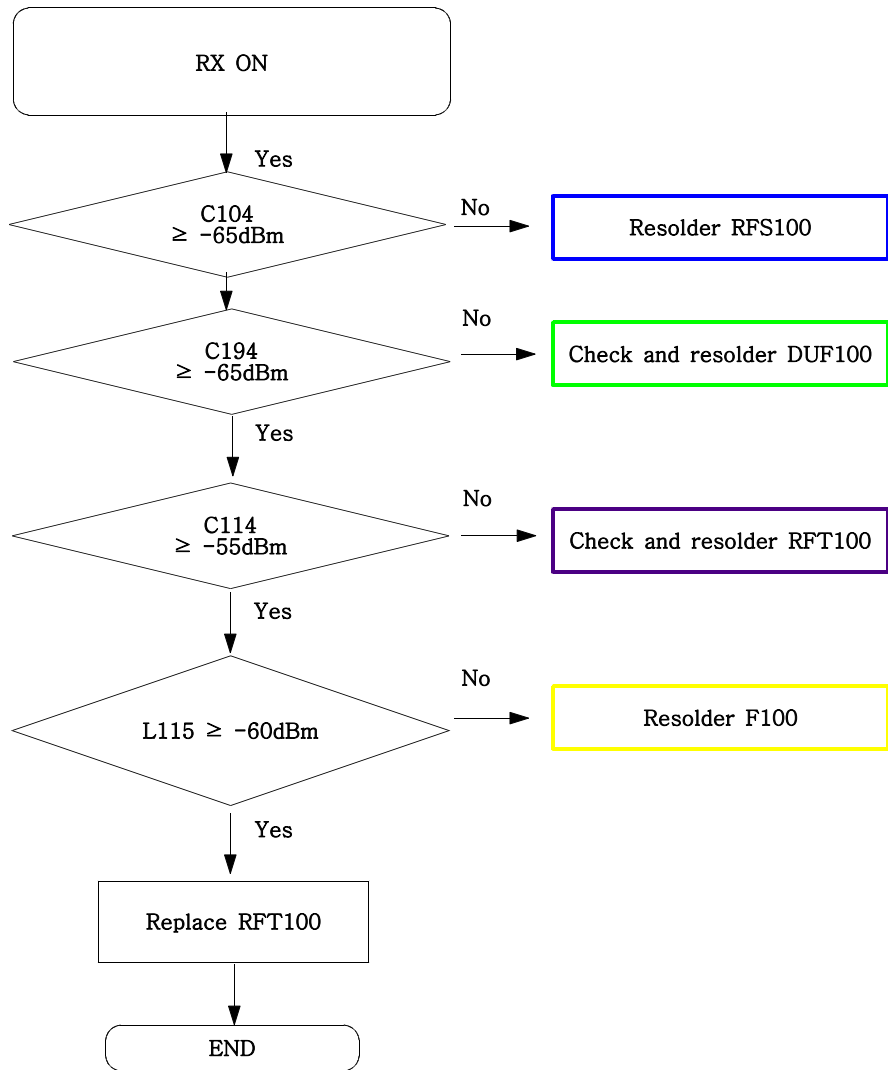

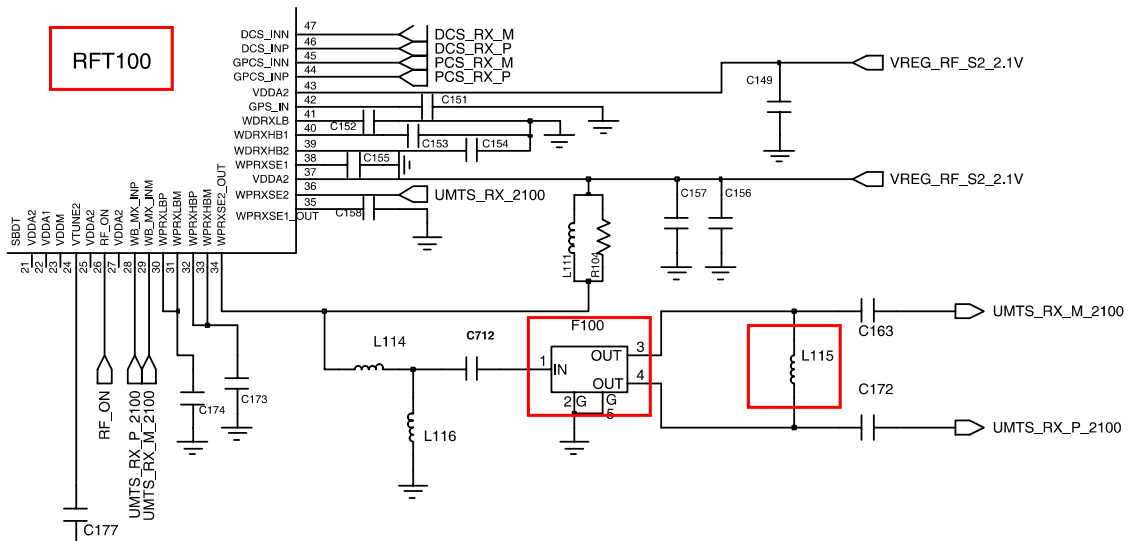
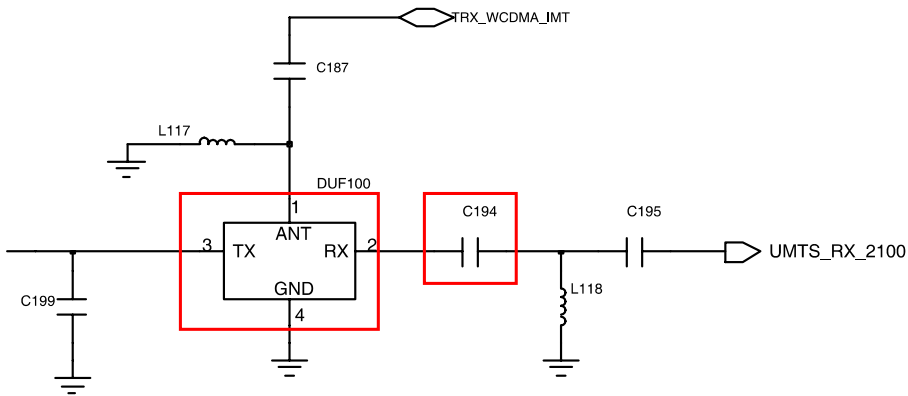
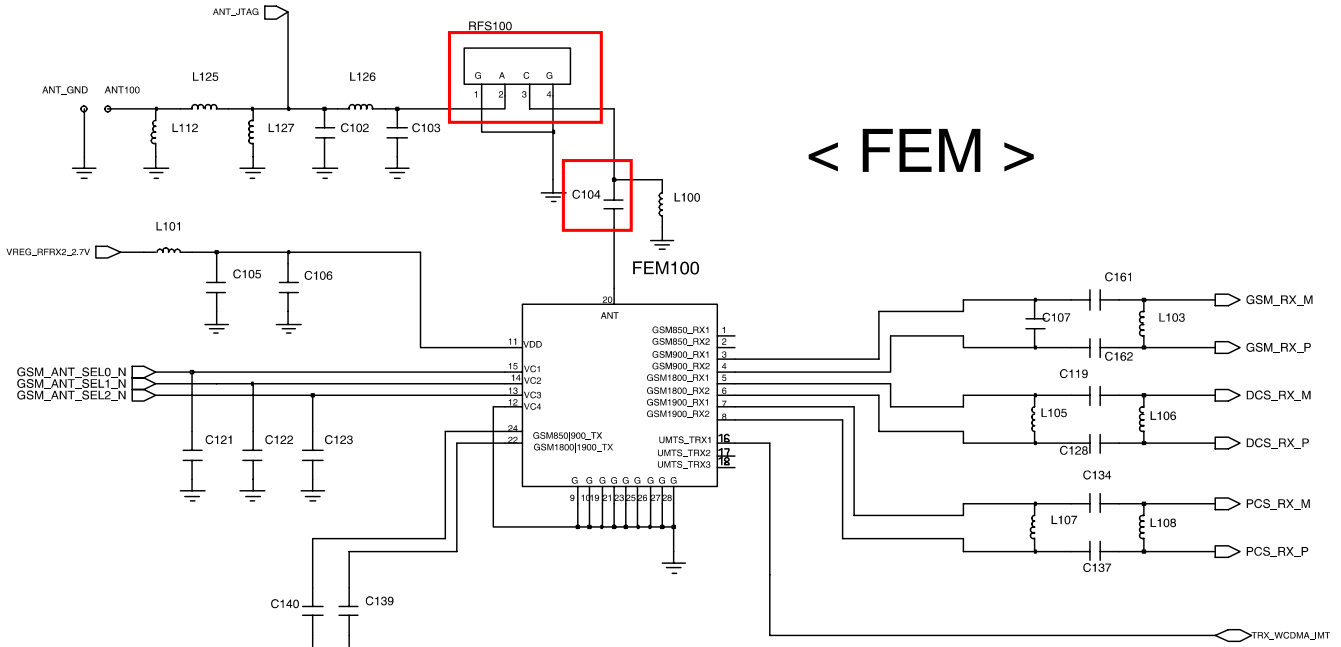

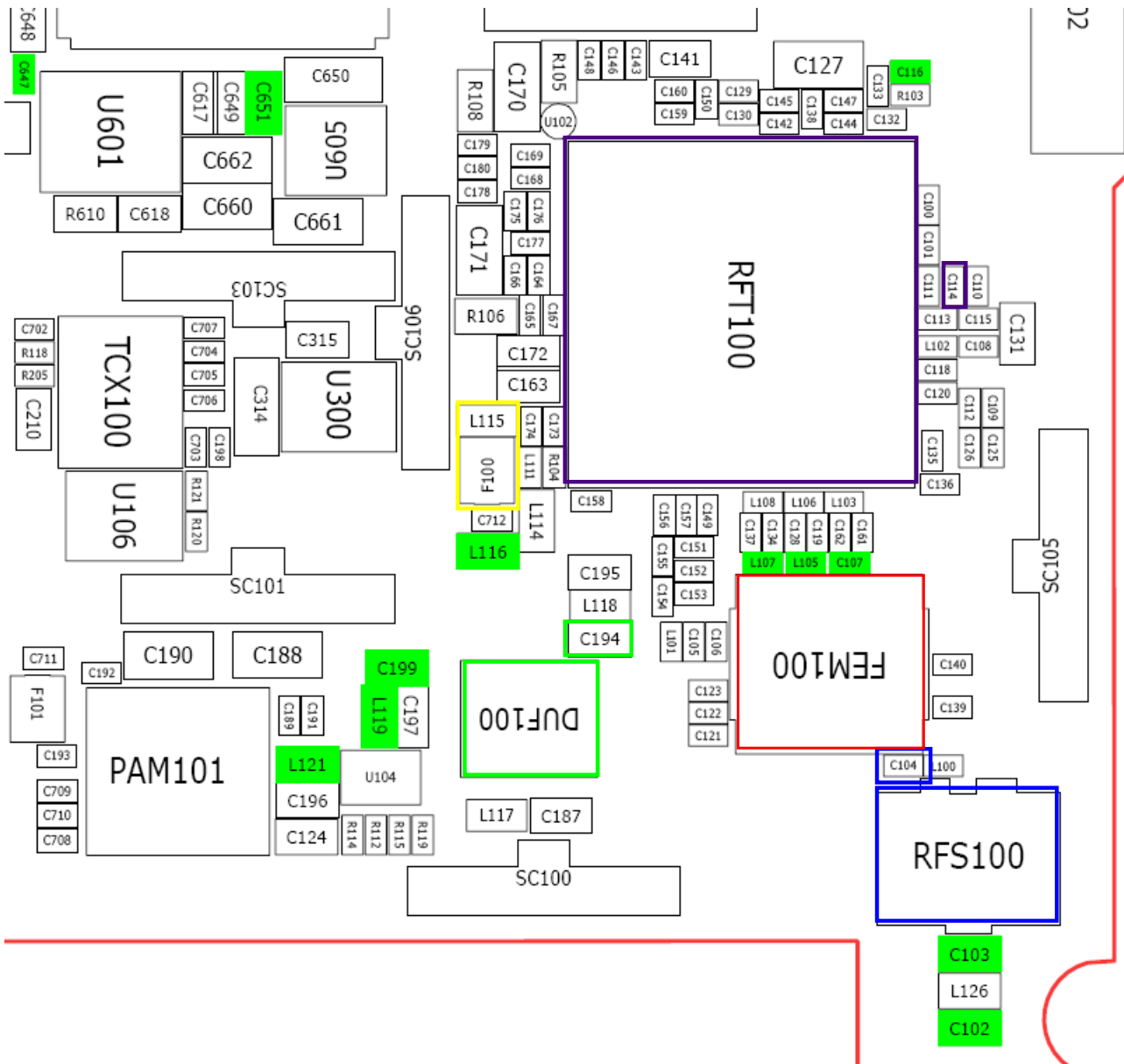

9-20. WCDMA Transmitter

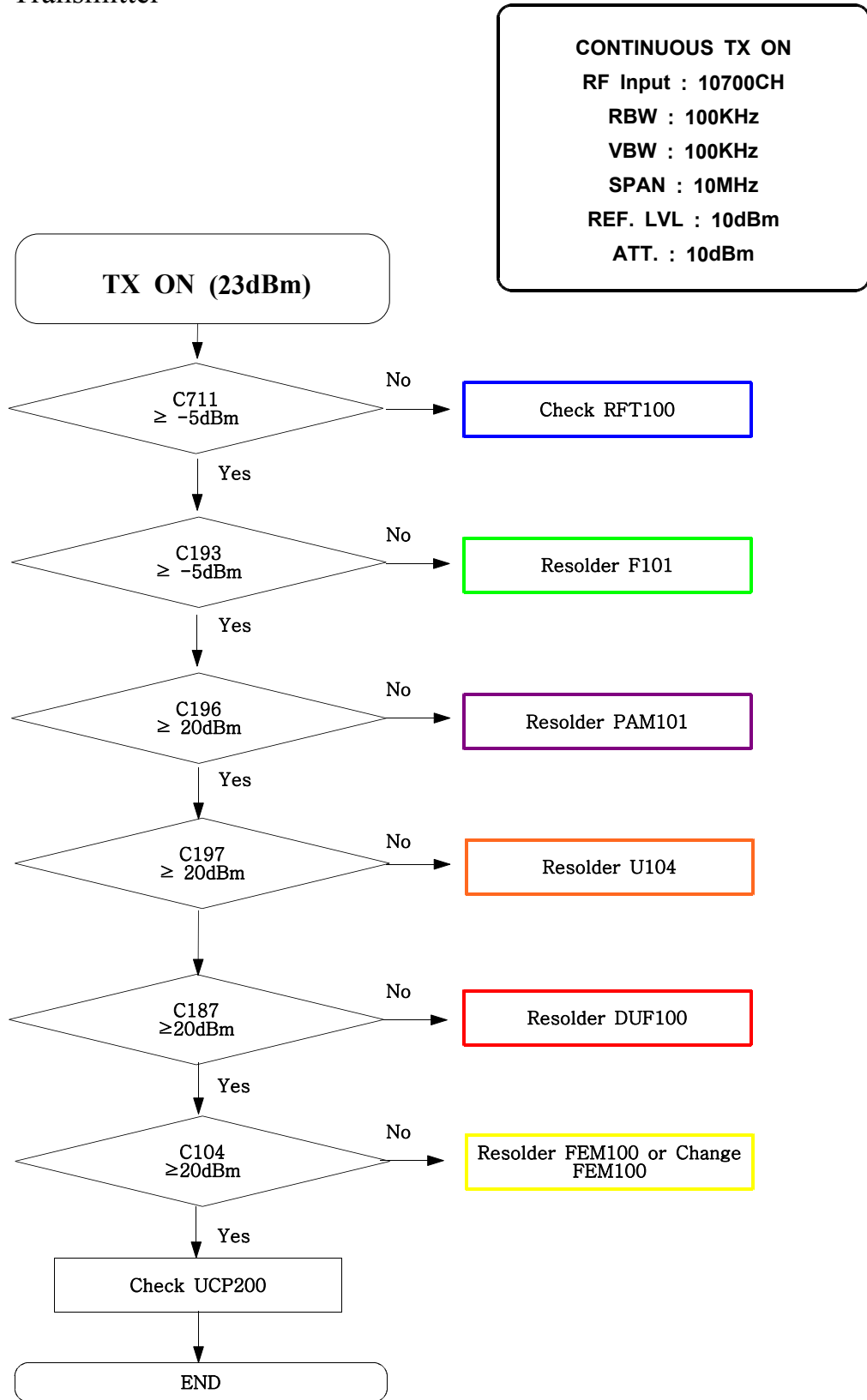

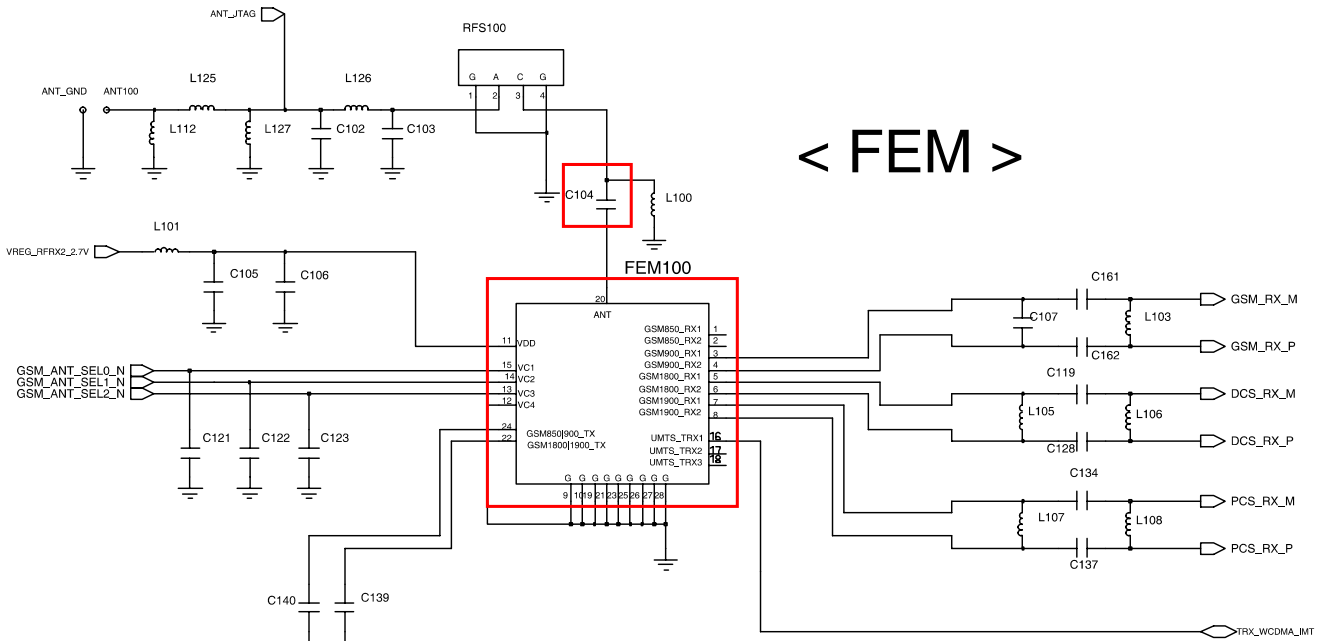
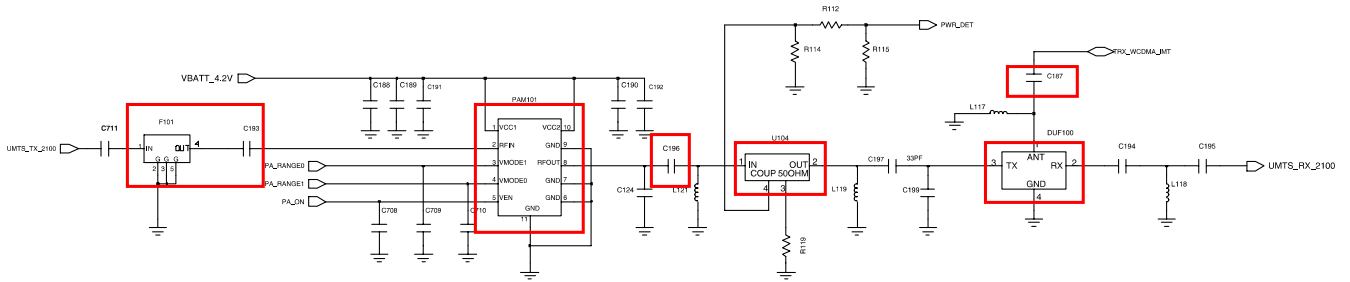



9-21. Bluetooth Part

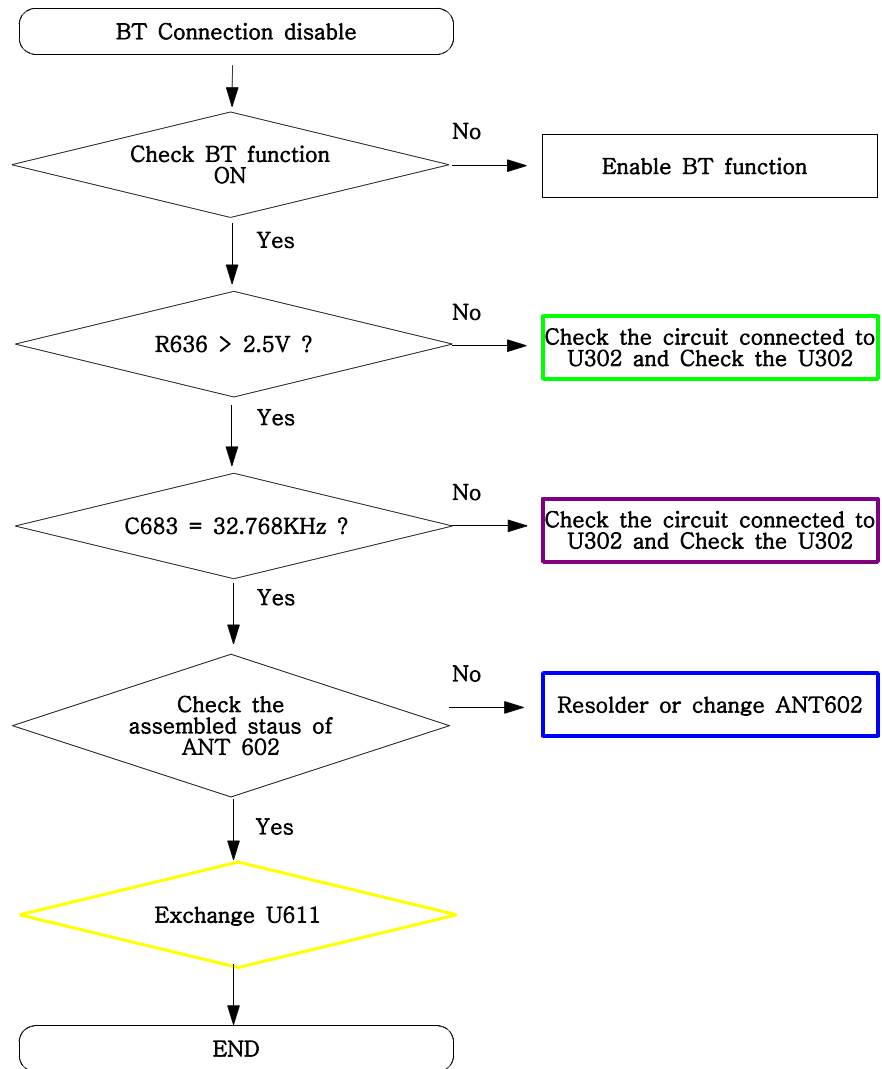

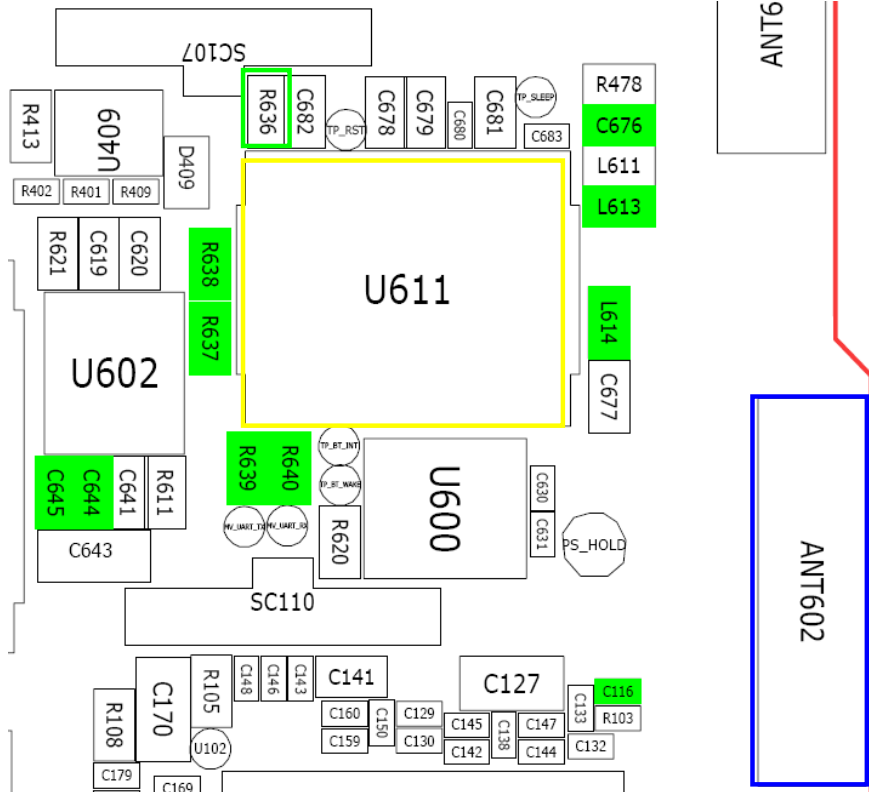
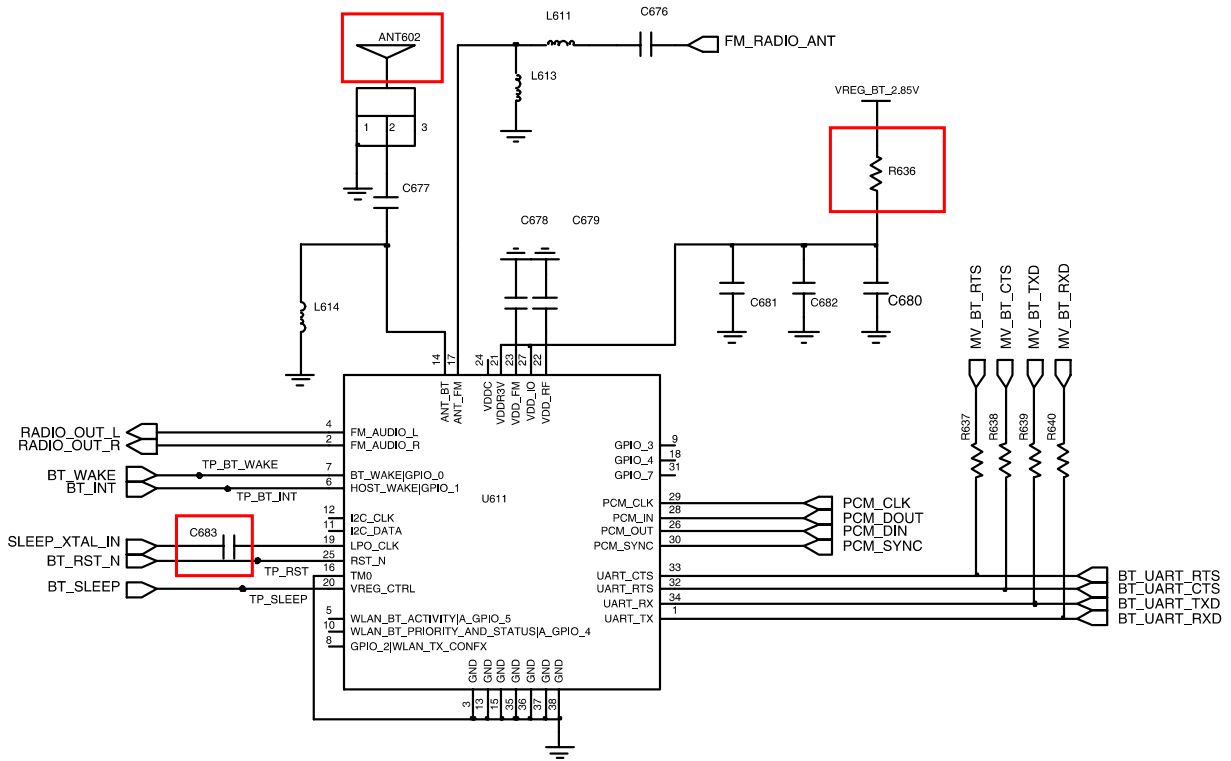

---

## 10. Reference data

---

### Reference Abbreviation

- **AAC**: Advanced Audio Coding.
- **AVC** : Advanced Video Coding.
- **BER** : Bit Error Rate
- **BPSK**: Binary Phase Shift Keying
- **CA** : Conditional Access
- **CDM** : Code Division Multiplexing
- **C/I** : Carrier to Interference
- **DMB** : Digital Multimedia Broadcasting
- **EN** : European Standard
- **ES** : Elementary Stream
- **ETSI**: European Telecommunications Standards Institute
- **MPEG**: Moving Picture Experts Group
- **PN** : Pseudo-random Noise
- **PS** : Pilot Symbol
- **QPSK**: Quadrature Phase Shift Keying
- **RS** : Reed-Solomon
- **SI** : Service Information
- **TDM** : Time Division Multiplexing
- **TS** : Transport Stream

# 11. Disassembly and Assembly Instructions

## 11-1. Disassembly Instructions

1

- 1) RELEASE SCREWS AT 6 POINT.
- 2) DISASSEMBLE REAR CASE.



2

- 1) RELEASE THE FIXED SCREW OF MAIN PBA. (1 POINT)
- 2) DISASSEMBLE KEY CONNECTOR.
- 3) DISASSEMBLE MAIN PBA.

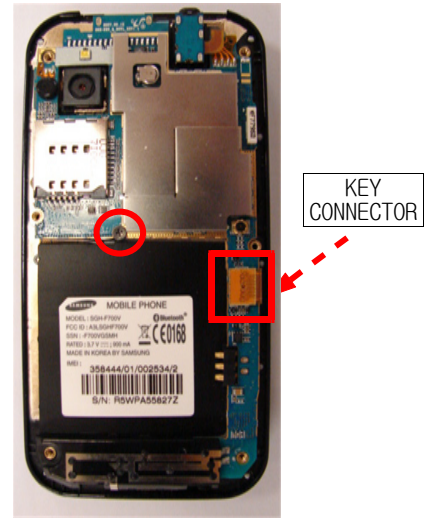

1) DO NOT MAKE SCRATCH ON CASE.

1) WHEN YOU DISASSEMBLE KEY CONNECTOR, TAKE CARE NOT TO DAMAGE F-PCB.

3

- 1) RELEASE THE FIXED SCREW OF SHIELD CAN. (4 POINT)
- 2) DISASSEMBLE SHIELD CAN.

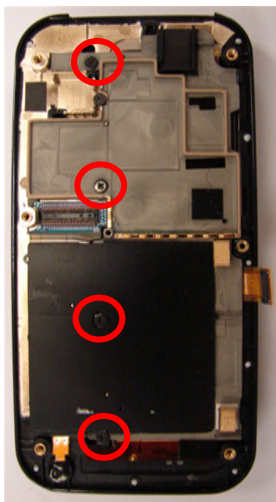

4

- 1) DISASSEMBLE KEY PAD.
- 2) DETACH THE FIXED GASKET TAPE OF SLIDE F-PCB.
- 3) PUSH SLIDE RIGHT SIDE.

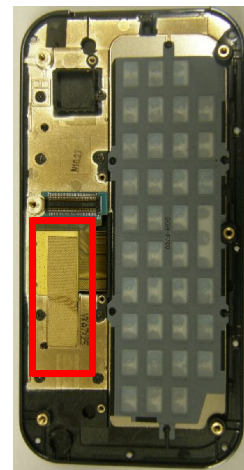

5

- 1) DETACH THE SCREW CAP OF LOWER CASE. (2 POINT)
- 2) DISASSEMBLE SLIDE ASS'Y AND RELEASE THE FIXED SCREW OF UPPER CASE. (3 POINTS)

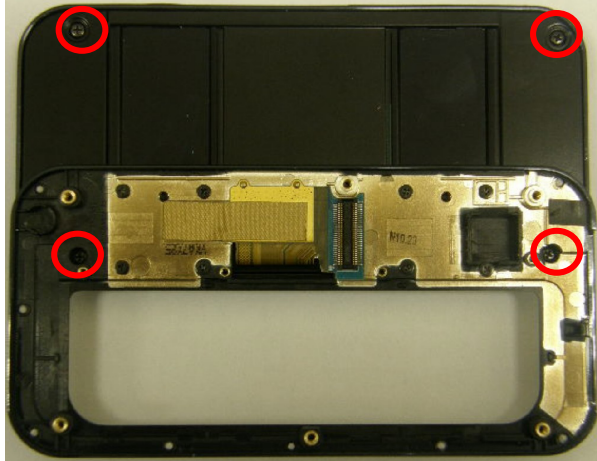

1) DO NOT MAKE SCRATCH ON CASE.

6

- 1) PUSH SLIDE INSIDE SLIGHTLY.
- 2) DISASSEMBLE SLIDE ASS'Y AND RELEASE THE FIXED SCREW OF UPPER CASE.(2 POINT)
- 3) DISASSEMBLE SLIDE ASS'Y.

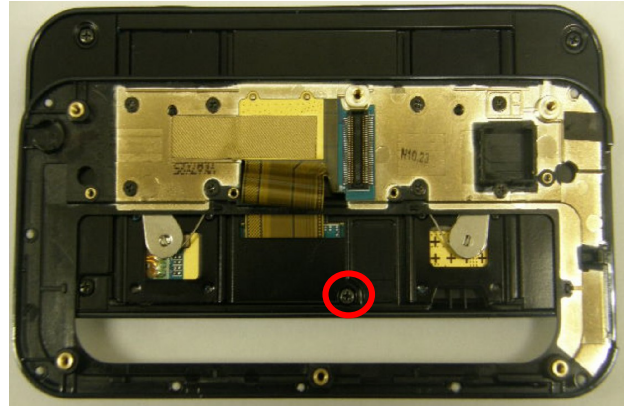

1) PLEASE MAKE SURE THAT THE F-PCB IS LOCATED IN THE MIDDLE OF SLOT.(OTHERWISE F-PCB WILL BE DAMAGED.)

7

- 1) DETACH INSULATION TAPE.

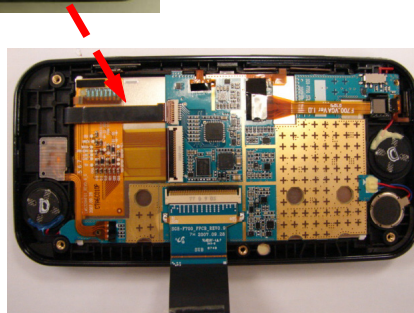
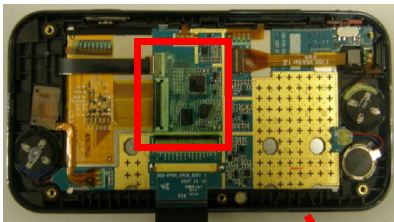

1) BE CAUTIOUS NOT TO DAMAGE TO COMPONENTS BY PINCETTE.

8

- 1) DISASSEMBLE LCD F-PCB AND TOUCH KEY F-PCB.
- 2) DISASSEMBLE SPEAKER(2EA) AND MOTOR(1EA).
- 3) USING PINCETTE, DISASSEMBLE POWER KEY, VOLUME KEY, CAMERA KEY, HOME KEY, SUB CKAMERA.

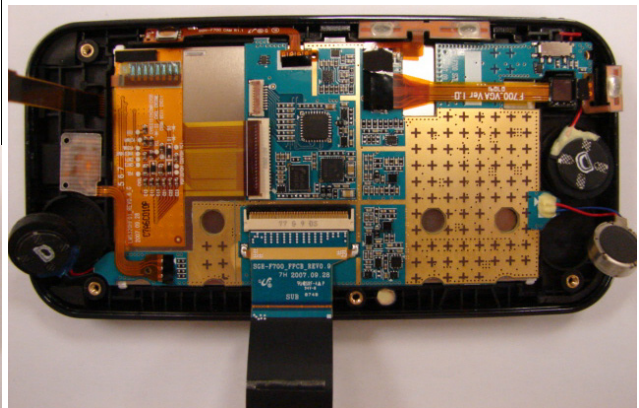

1) WHEN EACH SUB COMPONENTS ARE DISASSEMBLED, BE CAUTIOUS NOT TO DAMAGE TO COMPONENTS.

9

1) DISASSEMBLE SUB PCB.

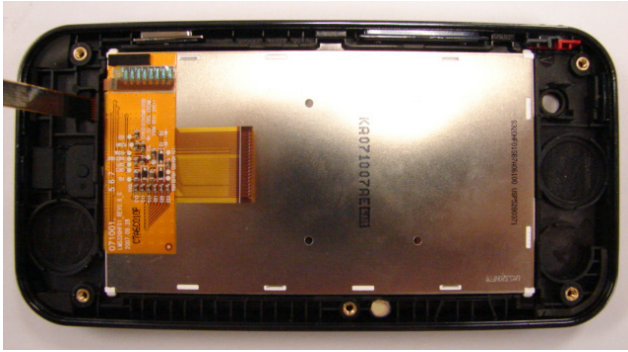

## 11-2. Assembly Instructions

1

1) CONNECT LCD F-PCB TO SUB PBA.

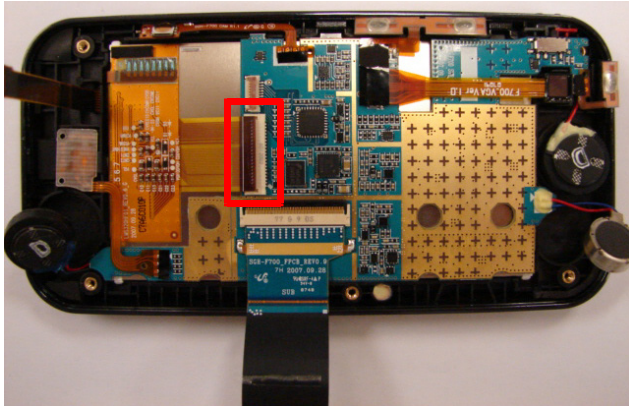

1) WHEN THE LCD F-PCB IS INSERTED,  
TAKE CARE NOT TO DAMAGE F-PCB.

2

1) CONNECT TOUCH KEY F-PCB.  
2) INSERT SPEAKER(2EA), MOTOR KEY, HOME KEY,  
,POWER KEY,VOLUME KEY,CKAMERA KEY.

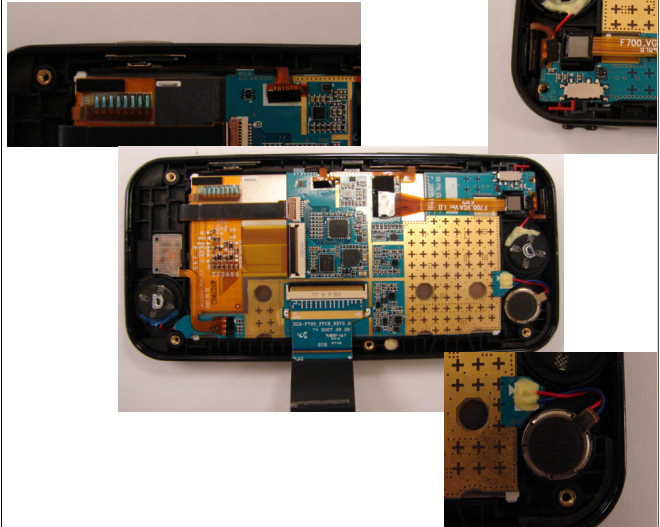

1) THE CAMERA KEY F-PCB MUST INSERT CORRECTLY  
INSIDE OF GUIDELINE.  
2) TAKE CARE NOT TO TWIST ALL OF WIRES.  
3) THE HOLD KEY MUST INSERT CORRECTLY INSIDE OF HALL  
GUIDELINE.

3

1) ATTACH INSULATION TAPE CORRECTLY.

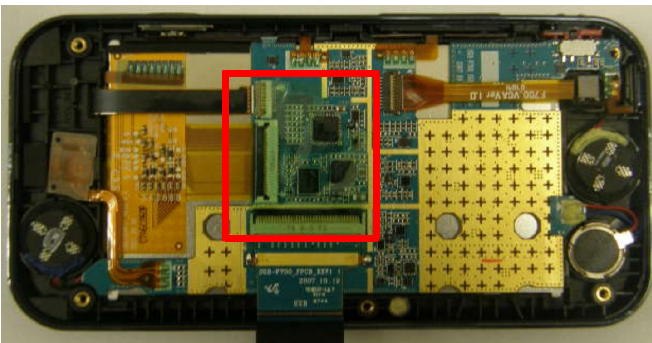

1) BE CAUTIOUS NOT TO DAMAGE TO COMPONENTS BY  
PINCETTE.

4

1) PASS SLIDE F-PCB THROUGH SLIDE ASS'Y.  
2) ASSEMBLE UPPER CASE AND SLIDE ASS'Y.  
3) DRIVE SCREWS AT 3 POINT.  
4) ATTACH SCREW CAPS AT 2 POINT.

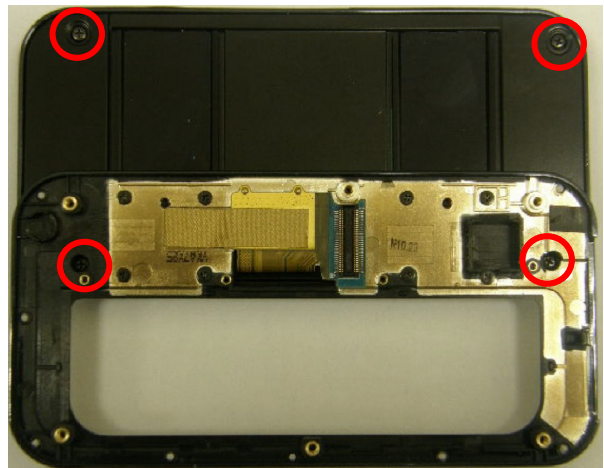

1) DO NOT MAKE SCRATCH ON CASE.

5

- 1) SLIDE UP SLIGHTLY.
- 2) DRIVE SCREWS AT 2 POINT.

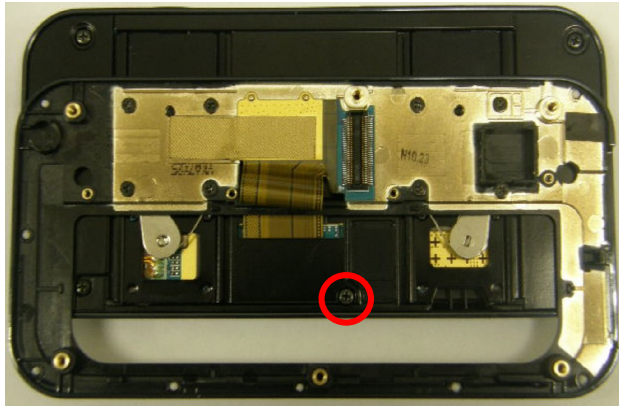

1) PLEASE MAKE SURE THAT THE F-PCB IS LOCATED IN THE MIDDLE OF SLOT. (OTHERWISE F-PCB WILL BE DAMAGED.)

6

- 1) ATTACH CONDUCTION GASKET.
- 2) INSERT CORRECTLY KEY PAD.

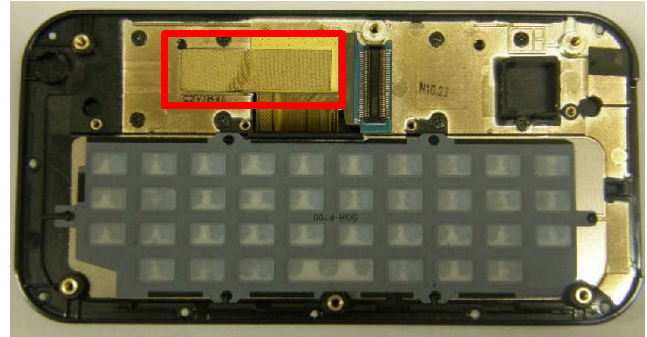

7

- 1) DRIVE SCREWS AT 4 POINT.

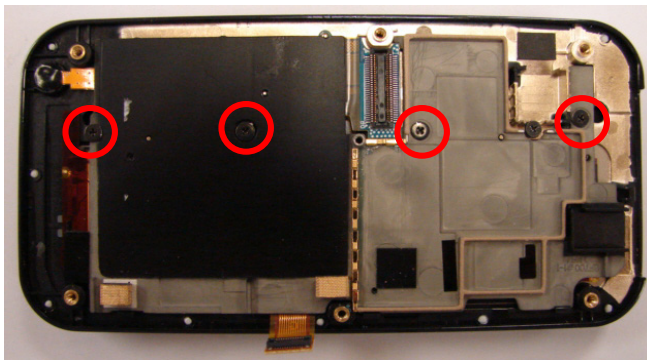

- 1) WHEN YOU ASSEMBLE, BE CAREFUL NOT TO DESTROY THE SHIELD GASKET.
- 2) USE AN AIR GUN NOT TO LEAVE ANY PARTICLE ON LCD CONNECTOR.

8

- 1) ATTACH MAIN PBA.
  1. AT FIRST, ATTACH MAIN CAMERA.
  2. TURN 180° THE EARJACK THEN INSERT IT.
- 2) ASSEMBLE KEY CONNECTOR.
- 3) DRIVE SCREWS AT 1 POINT.

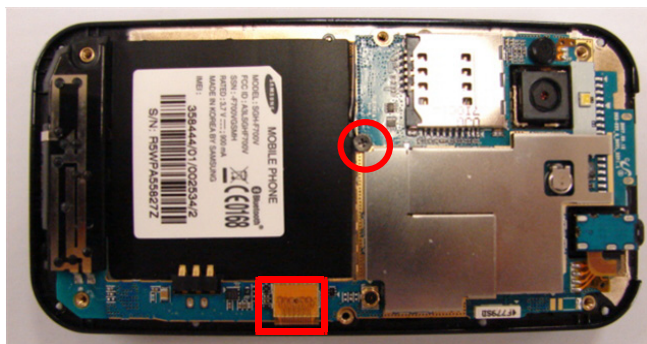

- 1) WHEN LCD CONNECTOR IS ASSEMBLED, CHECK IT OUT THERE IS "TICK" SOUND.
- 2) WHEN YOU DRIVE SCREWS, TAKE CARE NOT TO TOUCH THE COMPONENTS.

9

- 1) ASSEMBLE REAR CASE.
- 2) DRIVE SCREWS AT 6 POINT.



- 1) FIRSTLY, DRIVE SCREWS FROM THE BOTTOM ONES TO TOP ONES.
- 2) DO NOT MAKE SCRATCH ON CASE.

# 12. Schematic Diagram

## - NC Point(Top View)

UCP200

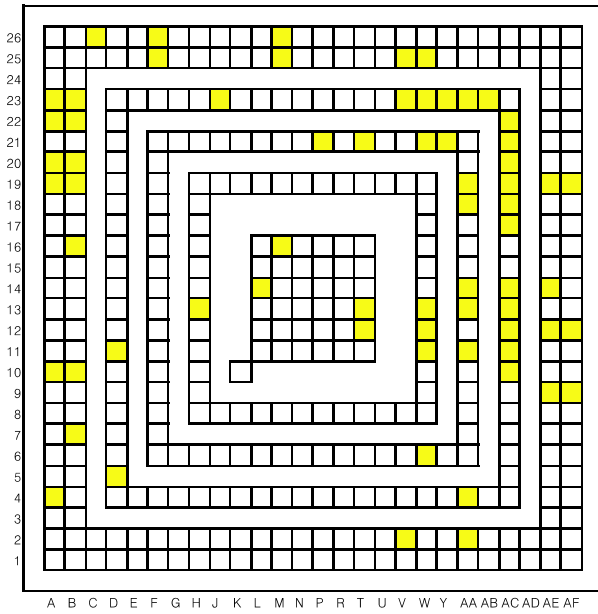

UME200

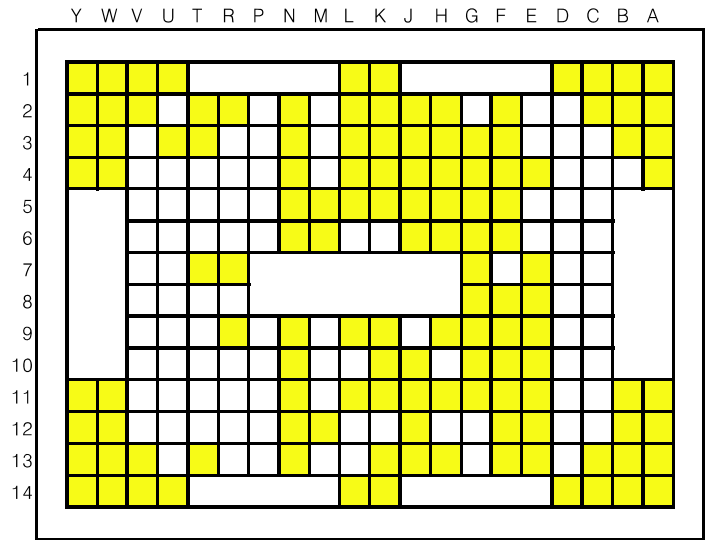

U503

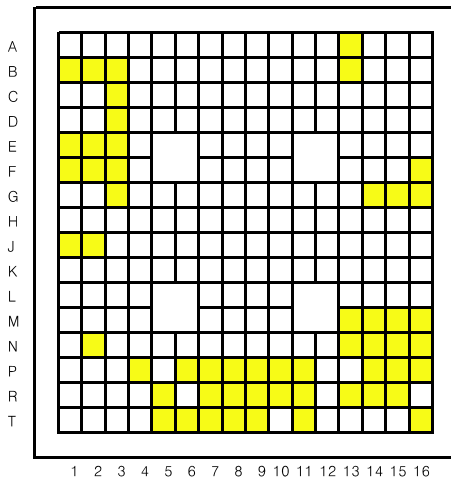

U302

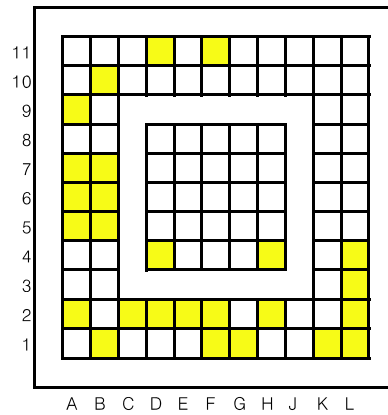

U604

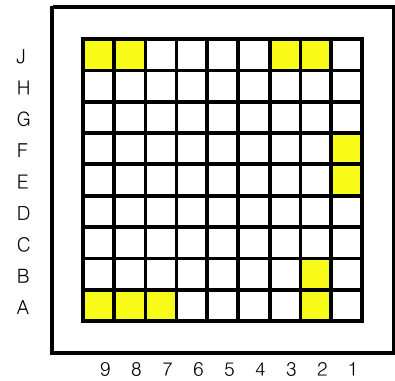

U204

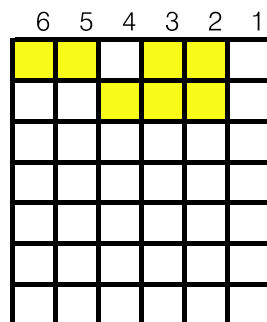

C522

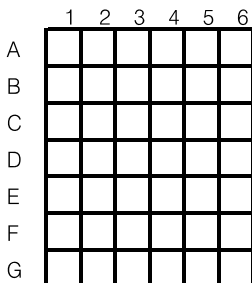

**SAMSUNG  
ELECTRONICS**



GSPN (Global Service Partner Network)

<b>Country</b>	<b>Web Site</b>
North America	service.samsungportal.com
Latin America	latin.samsungportal.com
CIS	cis.samsungportal.com
Europe	europe.samsungportal.com
China	china.samsungportal.com
Asia	asia.samsungportal.com
Mideast & Africa	mea.samsungportal.com