

# Trouble Shooting Guide, Mechanical

Applicable for P990

## Contents

<b>1</b>	<b>General</b> .....	<b>2</b>
1.1	Service functions in the software .....	2
1.2	Misuse and other no warranty issues .....	3
<b>2</b>	<b>Appearance Problems</b> .....	<b>6</b>
<b>3</b>	<b>Network/Signal Problems</b> .....	<b>7</b>
<b>4</b>	<b>On/Off Problems</b> .....	<b>9</b>
<b>5</b>	<b>Audio Problems</b> .....	<b>11</b>
<b>6</b>	<b>Key Problems</b> .....	<b>14</b>
<b>7</b>	<b>Display Problems</b> .....	<b>16</b>
<b>8</b>	<b>Illumination Problems</b> .....	<b>17</b>
<b>9</b>	<b>Alert Problems</b> .....	<b>19</b>
<b>10</b>	<b>SIM Problems</b> .....	<b>20</b>
<b>11</b>	<b>Charging/Capacity Problems</b> .....	<b>21</b>
<b>12</b>	<b>Data Communication Problems</b> .....	<b>23</b>
<b>13</b>	<b>Camera Problems</b> .....	<b>24</b>
<b>14</b>	<b>Software Problems</b> .....	<b>29</b>
<b>15</b>	<b>Revision History</b> .....	<b>30</b>

# 1 General

This document outlines the mechanical repairs that should be made in an attempt to fix the common failures that are seen in the field. To gain a complete understanding of how to test and repair a specific failure, this document should be used in conjunction with the Test Instructions, Mechanical and the Working Instructions, Mechanical.

## 1.1 Service functions in the software

The service menu will be accessed with the following key combination. Use the jog dial and keyboard.

**▲\*▼▼\*▼\*** if no flip is attached use X instead of \*

They are as follows:

**Service information**

**Service tests**

**Format internal disk**

The phones software has a built in service functionality that allows you to test some of the phones functions. (See point 2 above) It looks like this:

**Display**

**Camera**

**Touch screen**

**Illumination**

**LED's**

**Keyboard**

**Vibrator**

**Speaker's**

**Microphone**

**FM-radio**

**Memory stick**

**NOTE: Different names may occur depending on language setting and customization.**

## 1.2 Misuse and other no warranty issues





Misuse is not covered by warranty. This chapter will explain what's not covered by warranty. Phones that have been exposed to misuse will not be covered by warranty.

This means: if it is possible to repair the phone, the customer will have to pay for the repair. SEMC will not allow any of these phones to be claimed into WCMS. Some local perspectives may interfere with this. Please reference to local directives.

### 1.2.1 Action

Make a general visual inspection for misuse.

Below are some **examples** of what is not covered by warranty.

				
<p>Front window broken due to misuse.</p>	<p>LCD cracked due to drop.</p>	<p>Clear scratches</p>	<p>Mark after drop</p>	<p>Corrosion components on the PCB.</p>

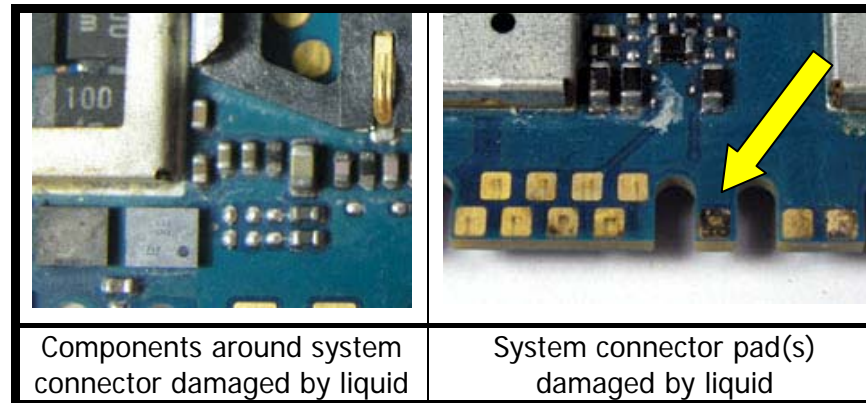
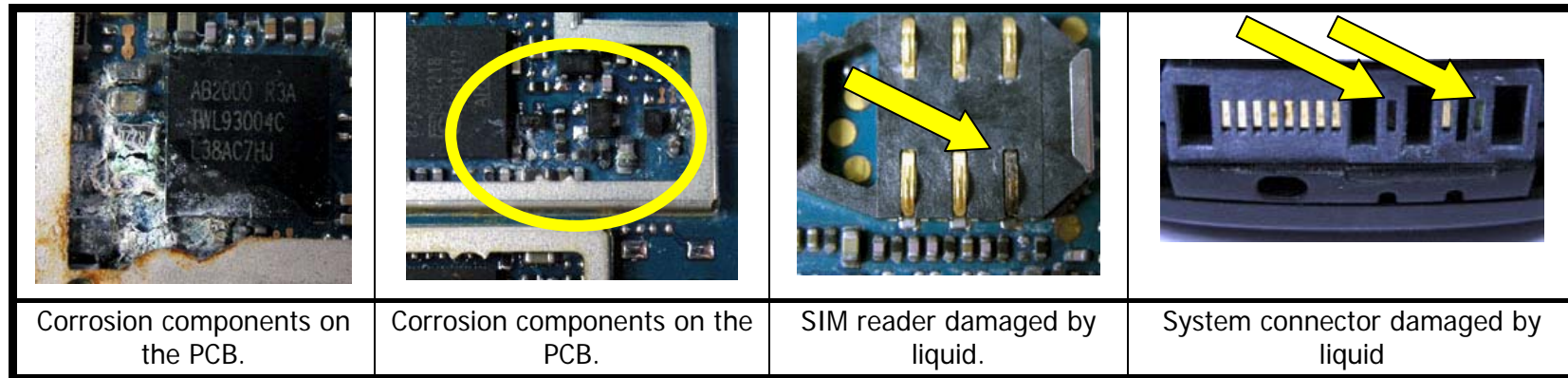

## 1.2.2 Liquid damage sticker

In the phone there is placed a sticker that can give you a hint to see if the phone is damage by liquid or not. This sticker is located near the SIM reader (Fig. 1.2.1) and it is possible to see it without disassemble the phone.

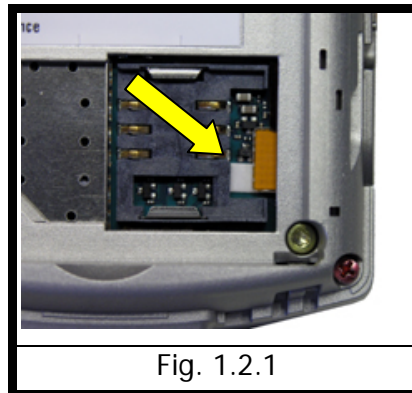
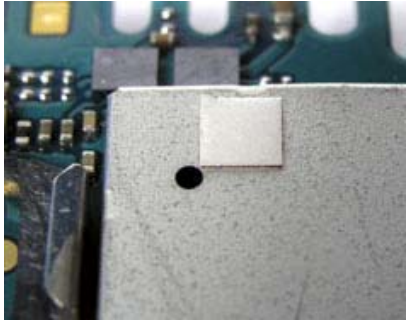
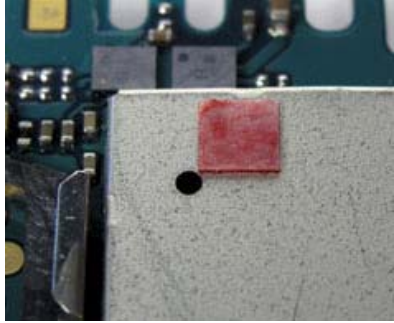

Fig. 1.2.1

On the pictures below you will see the different between a sticker that has been in contact with liquid (Fig. 1.2.3) and with one that hasn't (Fig. 1.2.2).

This sticker is ok	This sticker <u>is not</u> ok	
		<p>The white sticker that has been in contact with liquid turns into a red or pink sticker. In this case you should check the phone for liquid damage (See point 1.1.1).</p> <p>Note: There must be clear marks after liquid on the PCB before rejecting the phone for repair.</p>
<p>Fig. 1.2.3</p>	<p>Fig. 1.2.4</p>	

### 1.2.3 Action

Make a general visual inspection for misuse, corrosion or oxidation from liquid damage. No further action should be taken for a liquid damaged phone. Handle the unit according to local directives.

## 2 Appearance Problems

Problem Area	Items to Check	Repair Action	Reference Image
Appearance	Visually inspect the cosmetic quality of all user viewable surfaces	<ul style="list-style-type: none"> <li>If dirty – Clean parts as necessary.</li> <li>If unacceptably scratched or damaged – Replace damage parts as necessary.</li> </ul> <p><b>NOTE: Misuse is not covered by warranty. Refer to <a href="#">chapter 1.2</a></b></p>	
	Visually inspect all keys	<ul style="list-style-type: none"> <li>If dirty – Clean parts as necessary.</li> <li>If unacceptably scratched or damaged – Replace damaged parts as necessary.</li> </ul> <p><b>NOTE: Misuse is not covered by warranty. Refer to <a href="#">chapter 1.2</a></b></p>	
	Visually inspect for improper gap between seams	<ul style="list-style-type: none"> <li>Reassemble or replace damaged parts as necessary.</li> </ul>	

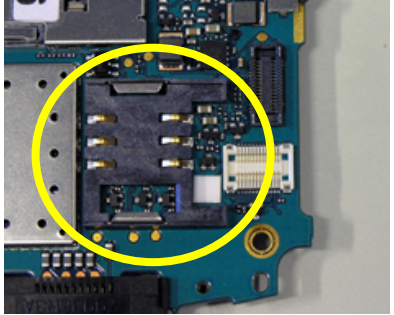
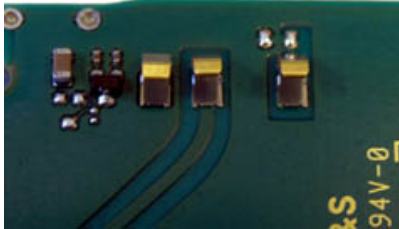
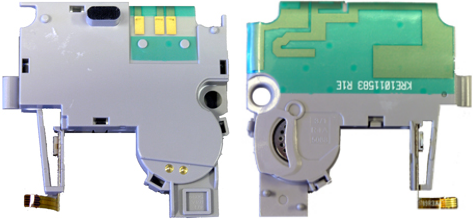

### 3 Network/Signal Problems

Problem Area	Items to Check	Repair Action	Reference Image
No Signal or Poor Signal	Before proceeding →	Perform a flash upgrade.	
	Visually inspect SIM holder	<ul style="list-style-type: none"> <li>If dirty, oxidized – Clean it</li> </ul> <p><b>Note: Be gentle do not bend or damage the gold surface on connector pins.</b></p>	
	Visually inspect antenna contact pads	<ul style="list-style-type: none"> <li>If dirty or oxidized – Send to electrical repair center</li> </ul> <p><b>NOTE: Do not try to clean.</b></p>	
	Visually inspect antenna	<ul style="list-style-type: none"> <li>If dirty, damaged or oxidized – Replace Antenna/Acoustic ASM.</li> </ul>	
	If the issue has not been resolved →	<ul style="list-style-type: none"> <li>Handle the unit according to local directives.</li> </ul>	

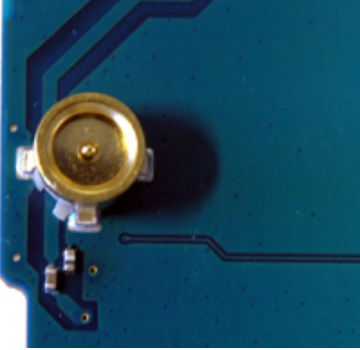
Problem Area	Items to Check	Repair Action	Reference Image
<p>No signal when using external antenna (ex. Hands free in car).</p>	<p>Connect the phone to a handsfree car kit connected with external antenna.</p> <p>Visually inspect the antenna bar on the phone.</p>	<ul style="list-style-type: none"> <li>If no or only very less signal – Push the middle pin of the ext. antenna connector a few times.</li> </ul> <p><b>Note: Be gently it might damage the connector.</b></p>	
	<p>If the issue has not been resolved →</p>	<ul style="list-style-type: none"> <li>Handle the unit according to local directives.</li> </ul>	



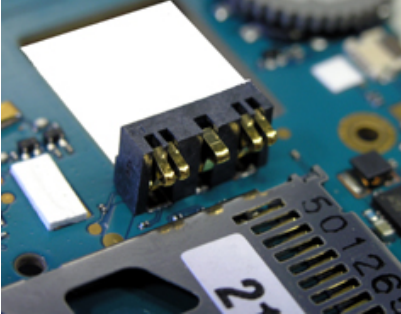

## 4 On/Off Problems

Problem Area	Items to Check	Repair Action	Reference Image
Power On problems	Check whether the phone vibrates 10 to 15 seconds after pressing the power key and whether the keypad illuminates	<ul style="list-style-type: none"> <li>If activation of the vibrator or keypad are detected, refer to the “Display Problems” <a href="#">chapter 7</a></li> </ul>	
	Before proceeding →	<ul style="list-style-type: none"> <li>Perform a flash upgrade.</li> </ul>	
	Visually inspect contact pads on battery	<ul style="list-style-type: none"> <li>If dirty or oxidized – Clean pads.</li> </ul> <p><b>Note: Be gentle do not bend or damage the gold surface on connector pads.</b></p> <ul style="list-style-type: none"> <li>If damaged – Replace the battery.</li> </ul>	
	Visually inspect battery connector	<ul style="list-style-type: none"> <li>If dirty or oxidized – Clean it.</li> </ul> <p><b>Note: Be gentle do not bend or damage the gold surface on connector pins.</b></p> <ul style="list-style-type: none"> <li>If damaged – Send to an electrical repair location.</li> </ul>	

Problem Area	Items to Check	Repair Action	Reference Image
	Visually inspect the power key	<ul style="list-style-type: none"> <li>If damaged – Replace it.</li> </ul>	
	If the issue has not been resolved →	<ul style="list-style-type: none"> <li>Handle the unit according to local directives.</li> </ul>	

## 5 Audio Problems

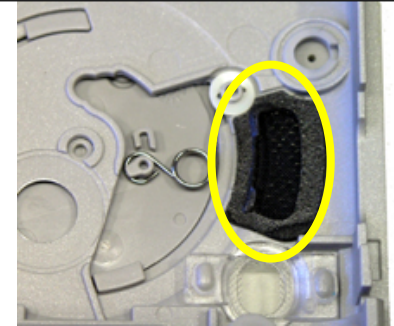

Problem Area	Items to Check	Repair Action	Reference Image
Microphone:	Before proceeding →	<ul style="list-style-type: none"> <li>Perform a flash upgrade and a setting reset.</li> </ul>	
	Visually inspect the microphone's external port	<ul style="list-style-type: none"> <li>If clogged - Clean the microphone net and check the microphone grommet and check the through hole on the circuit board to see that there is open space to the microphone on the circuit board.</li> </ul>	
	If the issue has not been resolved →	<ul style="list-style-type: none"> <li>Handle the unit according to local directives.</li> </ul>	
Ear speaker: No or poor sound quality	Before proceeding →	<ul style="list-style-type: none"> <li>Perform a flash upgrade and a setting reset.</li> </ul>	
	Visually inspect ear speaker's external port	<ul style="list-style-type: none"> <li>If clogged – Clean or replace Front sub ASM.</li> </ul>	

*Trouble Shooting Guide, Mechanical*

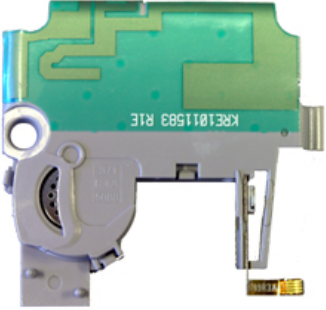
Problem Area	Items to Check	Repair Action	Reference Image
	If the issue has not been resolved →	<ul style="list-style-type: none"> <li>Replace ear speaker.</li> </ul> <p>Note: The gasket is a part of the delivered assembly.</p>	
	If the issue has not been resolved →	<ul style="list-style-type: none"> <li>Handle the unit according to local directives.</li> </ul>	
Loudspeaker: No or poor sound quality	Before proceeding →	<ul style="list-style-type: none"> <li>Perform a flash upgrade and a setting reset.</li> </ul>	
	Visually inspect the loud speaker's dust cloth	<ul style="list-style-type: none"> <li>If dirty or damaged – Replace the dust cover.</li> </ul>	

Problem Area	Items to Check	Repair Action	Reference Image
	If the issue has not been resolved →	<ul style="list-style-type: none"> <li>• Replace antenna/Acoustic ASM.</li> </ul>	
	If the issue has not been resolved →	<ul style="list-style-type: none"> <li>• Handle the unit according to local directives.</li> </ul>	

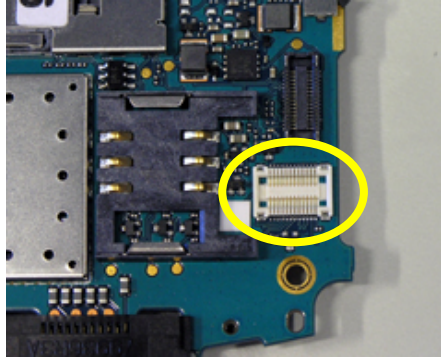
## 6 Key Problems



Problem Area	Items to Check	Repair Action	Reference Image
<b>Keyboard:</b> A key on the QWERTY keyboard or a side key is not functioning or is intermittent	Visually inspect if the BtB connector is properly connected.	<ul style="list-style-type: none"> <li>• If improperly connected – Re-establish proper connection.</li> <li>• If damaged – Send to electrical repair.</li> </ul>	
	Visually inspect for debris between keyboard QWERTY and LCD frame ASM and for damage to the keyboard QWERTY or LCD frame ASM.	<ul style="list-style-type: none"> <li>• If dirty – Clean both parts.</li> <li>• If damaged - Replace keyboard QWERTY and/or LCD frame ASM as necessary.</li> </ul>	
	If the issue has not been resolved →	<ul style="list-style-type: none"> <li>• Replace LCD frame ASM if it has not already been replaced.</li> </ul>	
	If the issue has not been resolved →	<ul style="list-style-type: none"> <li>• Handle the unit according to local directives.</li> </ul>	



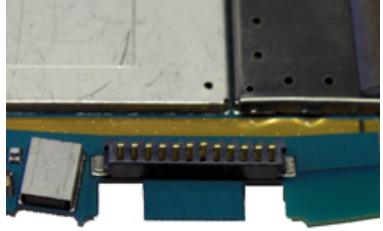
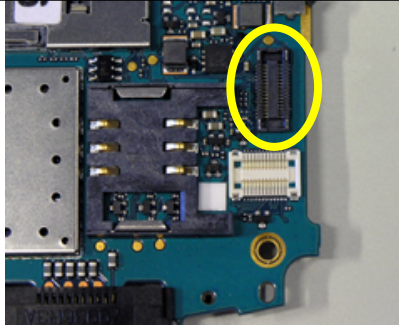
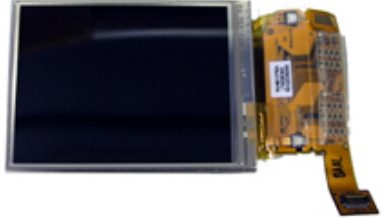

*Trouble Shooting Guide, Mechanical*

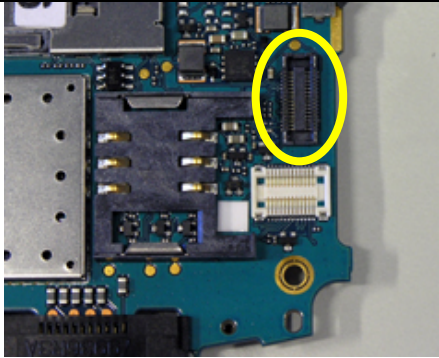
<b>Problem Area</b>	<b>Items to Check</b>	<b>Repair Action</b>	<b>Reference Image</b>
Keyboard: A key on the flip (1,2,3 keyboard) is not functioning or is intermittent	Visually inspect flip connector	<ul style="list-style-type: none"> <li>• If dirty or oxidized – Clean it</li> <li>• If damaged – Send to electrical repair</li> </ul>	
Touch screen	Visually inspect if the BtB connector is properly connected	<ul style="list-style-type: none"> <li>• If improperly connected – Re-establish proper connection.</li> <li>• If damaged – Send to electrical repair.</li> </ul>	
	Visually inspect for damage to the touch screen	<ul style="list-style-type: none"> <li>• If damaged – Replace touch panel assy</li> </ul> <p><b>Note: Check mechanical repair instruction for details.</b></p>	
	If the issue has not been resolved →	<ul style="list-style-type: none"> <li>• Handle the unit according to local directives.</li> </ul>	

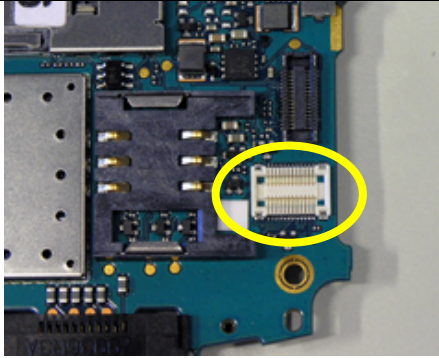

## 7 Display Problems

Problem Area	Items to Check	Repair Action	Reference Image
LCD problem	Check whether the phone vibrates 10 to 15 seconds after pressing the power key and whether the keypad illuminates	<ul style="list-style-type: none"> <li>If activation of the vibrator are <b>not detected</b>, refer to the On/Off Problems" <a href="#">chapter 4</a></li> </ul>	
	Before proceeding →	<ul style="list-style-type: none"> <li>Perform a flash upgrade and a setting reset.</li> </ul>	
	Visually inspect if the BtB connector is properly connected	<ul style="list-style-type: none"> <li>If improperly connected – Re-establish proper connection.</li> <li>If damaged – Send to electrical repair.</li> </ul>	
	If the issue has not been resolved →	<ul style="list-style-type: none"> <li>Replace the LCD.</li> </ul> <p><b>Note: When replacing display take care not to damage the LCD gaskets.</b></p>	

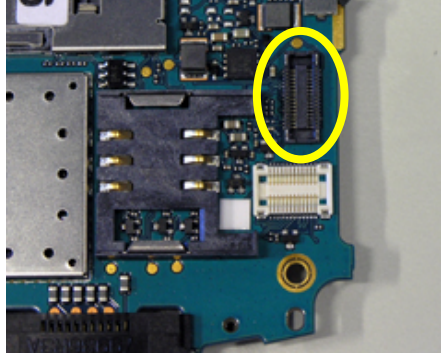

## 8 Illumination Problems

Problem Area	Items to Check	Repair Action	Reference Image
<b>Keys QWERTY:</b> The entire keypad or a portion of the keypad does not illuminate.	Before proceeding →	<ul style="list-style-type: none"> <li>Perform a flash upgrade and a setting reset.</li> </ul>	
	Visually inspect if the BtB connector is properly connected	<ul style="list-style-type: none"> <li>If improperly connected – Re-establish proper connection.</li> <li>If damaged – Send to electrical repair.</li> </ul>	
	Visually inspect the LCD frame ASM.	<ul style="list-style-type: none"> <li>If damaged – Replace it</li> </ul>	
	If the issue has not been resolved →	<ul style="list-style-type: none"> <li>Replace the LCD frame ASM if it has not already been replaced.</li> </ul>	
If the issue has not been resolved →	<ul style="list-style-type: none"> <li>Handle the unit according to local directives.</li> </ul>		

*Trouble Shooting Guide, Mechanical*

<b>Problem Area</b>	<b>Items to Check</b>	<b>Repair Action</b>	<b>Reference Image</b>
LCD	Before proceeding →	<ul style="list-style-type: none"> <li>Perform a flash upgrade and a setting reset.</li> </ul>	
	Visually inspect if the BtB connector is properly connected	<ul style="list-style-type: none"> <li>If improperly connected – Re-establish proper connection.</li> <li>If damaged – Send to electrical repair.</li> </ul>	
	If issue has not been resolved →	<ul style="list-style-type: none"> <li>Replace the LCD.</li> </ul> <p><b>Note: When replacing display take care not to damage the LCD gasket.</b></p>	
	If the issue has not been resolved →	<ul style="list-style-type: none"> <li>Handle the unit according to local directives.</li> </ul>	

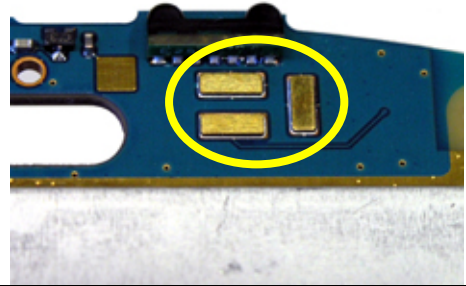
## 9 Alert Problems

Problem Area	Items to Check	Repair Action	Reference Image
Vibrator:	Before proceeding →	<ul style="list-style-type: none"> <li>Perform a flash upgrade and a setting reset.</li> </ul>	
	Visually inspect the vibrator pads on the PCB	<ul style="list-style-type: none"> <li>If dirty or oxidized – Clean them.</li> </ul>	
	Visually inspect the vibrator	<ul style="list-style-type: none"> <li>If dirty or oxidized – Replace it.</li> <li>If damaged – Replace it.</li> </ul>	
Loud speaker:	Refer to <b>“loudspeaker”</b> section under <a href="#">“Audio Problems”</a>		

## 10 SIM Problems

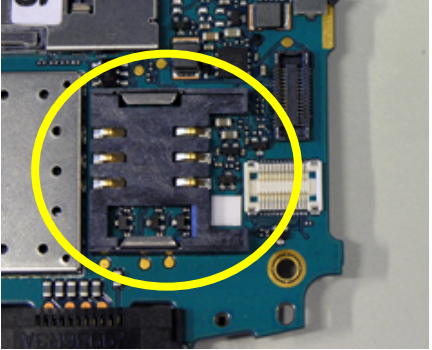
Problem Area	Items to Check	Repair Action	Reference Image
SIM undetected <b>(Insert SIM)</b>	Inspect SIM holder	<ul style="list-style-type: none"> <li>• If dirty or oxidized – Clean it.</li> <li>• If damaged – Send to electrical repair.</li> </ul>	
	If the issue has not been resolved →	<ul style="list-style-type: none"> <li>• Handle the unit according to local directives.</li> </ul>	
Unit indicates an incorrect SIM is inserted <b>(Insert correct SIM)</b>	Check whether the phone is locked to a particular carrier and whether the correct carrier's SIM is being used	<ul style="list-style-type: none"> <li>• Use Correct Carrier SIM or test SIM.</li> </ul>	
	If the issue has not been resolved →	<ul style="list-style-type: none"> <li>• Handle the unit according to local directives.</li> </ul>	



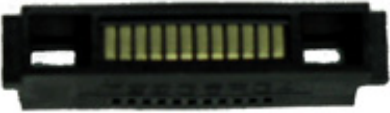
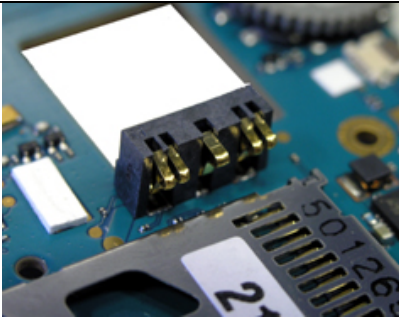

## 11 Charging/Capacity Problems

Problem Area	Items to Check	Repair Action	Reference Image
Battery will not charge	Visually inspect the contact pads of the battery	<ul style="list-style-type: none"> <li>• If dirty or oxidized – Clean.</li> <li>• If damaged – Replace battery.</li> </ul> <p><b>Note: Be gentle do not bend or damage the gold surface on connector pad's</b></p>	
	Visually inspect the system connector	<ul style="list-style-type: none"> <li>• If dirty, oxidized or damaged – Clean.</li> </ul> <p><b>Note: Misuse is not covered by warranty. Refer to <a href="#">chapter 1.2</a></b></p>	
	Visually inspect the battery connector	<ul style="list-style-type: none"> <li>• If dirty or oxidized – Clean it.</li> <li>• If damaged – Send to an electrical repair location.</li> </ul> <p><b>Note: Be gentle do not bend or damage the gold surface on connector pin's</b></p>	

Battery loses charge quickly/ standby time seems short	Before proceeding →	<ul style="list-style-type: none"> <li>Perform a flash upgrade and a setting reset.</li> </ul>	
	<b>NOTE: Some features noticeably reduce the amount of standby time if they are turned on. Some examples are the back light (when on all the time and), Bluetooth and infrared.</b>		
	If the issue has not been resolved →	<ul style="list-style-type: none"> <li>Replace battery.</li> </ul>	
	If the issue has not been resolved →	<ul style="list-style-type: none"> <li>Handle the unit according to local directives.</li> </ul>	

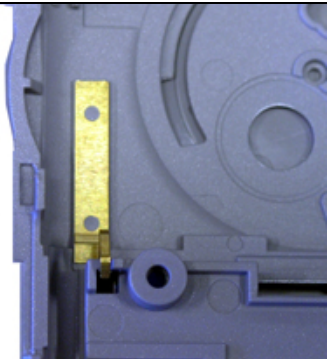

## 12 Data Communication Problems

Problem Area	Items to Check	Repair Action	Reference Image
Will not connect with a functional bluetooth device	Before proceeding →	Perform a flash upgrade.	
	Visually inspect bluetooth antenna	<ul style="list-style-type: none"> <li>If damaged – Replace frame ASM.</li> </ul>	
	If the issue has not been resolved →	<ul style="list-style-type: none"> <li>Handle the unit according to local directives.</li> </ul>	
Will not connect with a functional IR device	Before proceeding →	<ul style="list-style-type: none"> <li>Perform a flash upgrade and a setting reset.</li> </ul>	
	Visually inspect the IRDA window for dirt, scratches, and damage	<ul style="list-style-type: none"> <li>If dirty – Clean it.</li> <li>If damaged – Replace the frame ASM.</li> </ul>	
	If the issue has not been resolved →	<ul style="list-style-type: none"> <li>Handle the unit according to local directives.</li> </ul>	

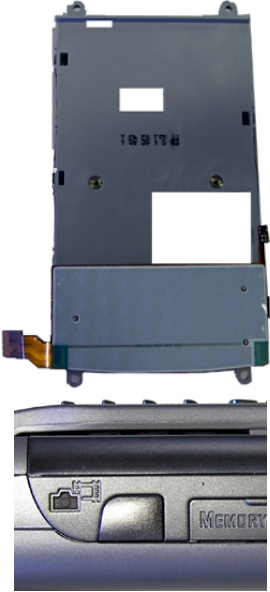
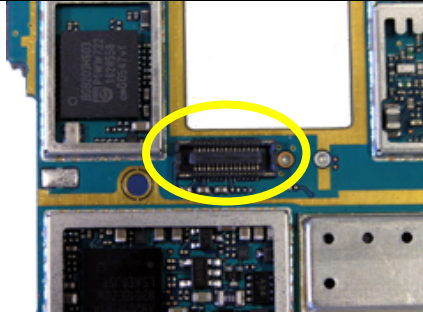
## 13 Camera Problems

Problem Area	Items to Check	Repair Action	Reference Image
Camera rear (2M pixels) Will not capture an image	Visually inspect for debris between and/or damage to the camera key and the LCD frame ASM.	<ul style="list-style-type: none"> <li>• If dirty – Clean both parts.</li> <li>• If damaged - Replace the camera key and/or the cabinet upper sub ASM as necessary.</li> </ul>	
	Visually inspect if the BtB connector is properly connected	<ul style="list-style-type: none"> <li>• If improperly connected – Re-establish proper connection.</li> <li>• If damaged – Send to electrical repair.</li> </ul>	
	If the issue has not been resolved →	<ul style="list-style-type: none"> <li>• Replace the LCD frame ASM if it has not already been replaced.</li> </ul>	

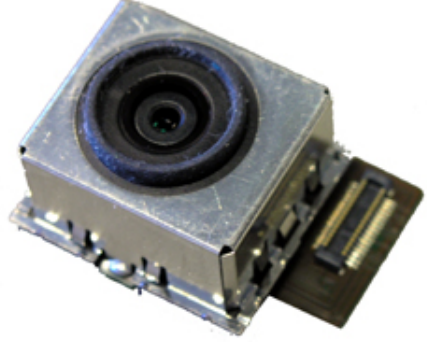
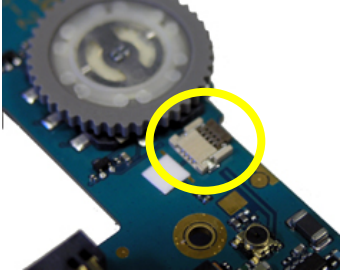
*Trouble Shooting Guide, Mechanical*

Problem Area	Items to Check	Repair Action	Reference Image
	If the issue has not been resolved →	<ul style="list-style-type: none"> <li>Replace camera 2M pixels.</li> </ul>	
	If the issue has not been resolved →	<ul style="list-style-type: none"> <li>Handle the unit according to local directives.</li> </ul>	
Will not start camera	Visually inspect if the BtB connector is properly connected	<ul style="list-style-type: none"> <li>If improperly connected – Re-establish proper connection.</li> <li>If damaged – Send to electrical repair.</li> </ul>	
	Visually inspect flex film, camera cover switch	<ul style="list-style-type: none"> <li>If damaged – Replace it.</li> </ul>	

*Trouble Shooting Guide, Mechanical*

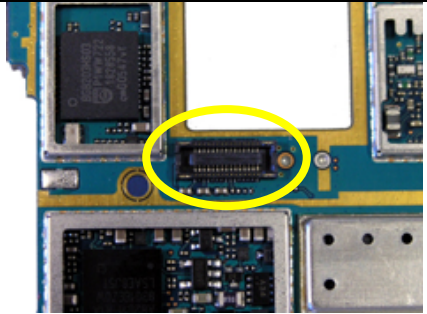
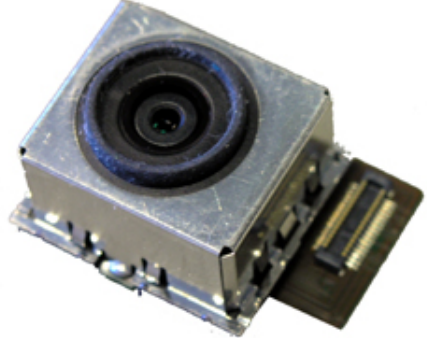
Problem Area	Items to Check	Repair Action	Reference Image
Lines, marks, blurred or discolored picture/ Will not enter camera menu	Visually inspect if the BtB connector is properly connected	<ul style="list-style-type: none"> <li>• If improperly connected – Re-establish proper connection.</li> <li>• If damaged – Send to electrical repair.</li> </ul>	
	If the issue has not been resolved →	<ul style="list-style-type: none"> <li>• Replace the camera 2M pixels.</li> </ul>	
	If the issue has not been resolved →	<ul style="list-style-type: none"> <li>• Handle the unit according to local directives.</li> </ul>	

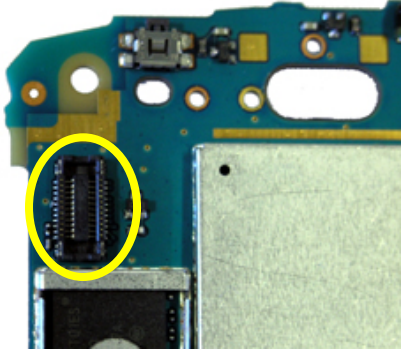
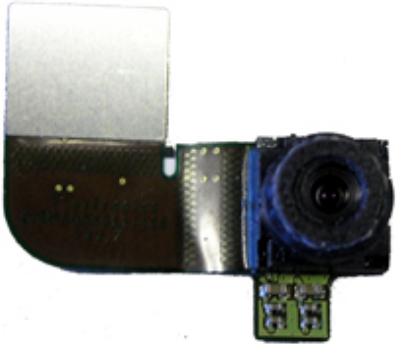

<b>Problem Area</b>	<b>Items to Check</b>	<b>Repair Action</b>	<b>Reference Image</b>
Camera front (Video call camera)	Visually inspect if the BtB connector is properly connected	<ul style="list-style-type: none"> <li>• If improperly connected – Re-establish proper connection.</li> <li>• If damaged – Send to electrical repair.</li> </ul>	
	If the issue has not been resolved →	<ul style="list-style-type: none"> <li>• Replace the camera front.</li> </ul>	

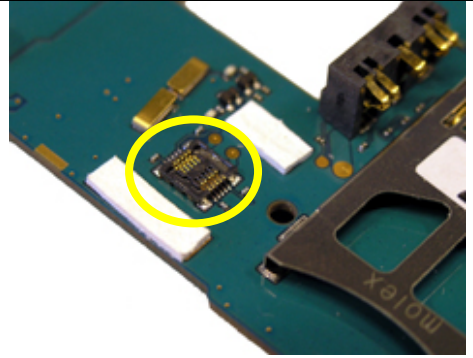
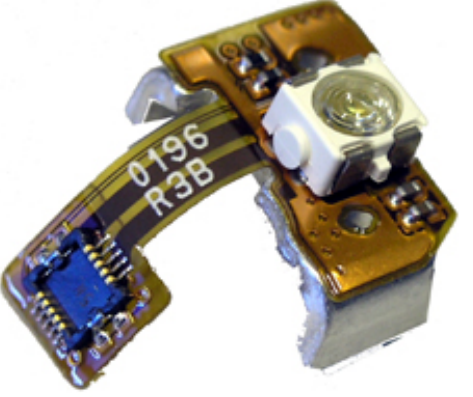
Problem Area	Items to Check	Repair Action	Reference Image
Camera light	Visually inspect if the BtB connector is properly connected	<ul style="list-style-type: none"> <li>• If improperly connected – Re-establish proper connection.</li> <li>• If damaged – Send to electrical repair.</li> </ul>	
	If the issue has not been resolved →	<ul style="list-style-type: none"> <li>• Replace the flash flex ASM.</li> </ul>	

## 14 Software Problems

- If there are problems with the response of the keypad commands, or spelling errors in the menu, if they are not related to mechanical damage, make a master reset and flash the phone with the latest software from EMMA II or III.
- Checking the software revision can be done in the Service info, see chapter *Service functions in the software*.  
Choose: Service info / SW information.  
The Software revision and date will be shown in the display.

**Note:** Do a SW upgrade before sending the unit to a higher level. Do **not** scrap a phone that hasn't been upgraded.

If the failure still occurs, handle the unit according to the local directives.

## 15 Revision History

Rev.	Date	Changes / Comments
A	2006-07-11	First draft