

11.2. Circuit Diagram of Main PCB (RF Band)

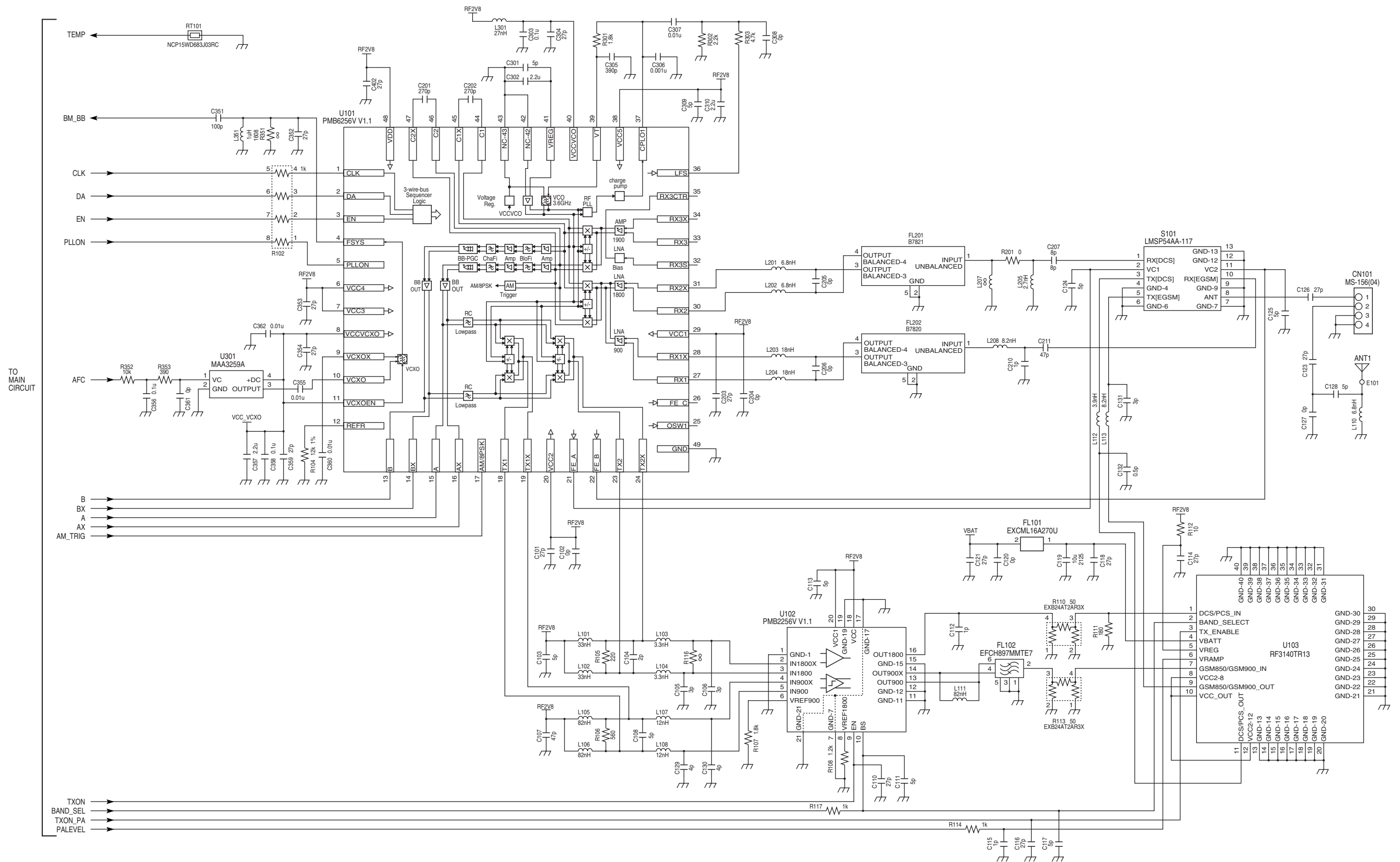

11.3. Circuit Diagram of Upper Face PCB

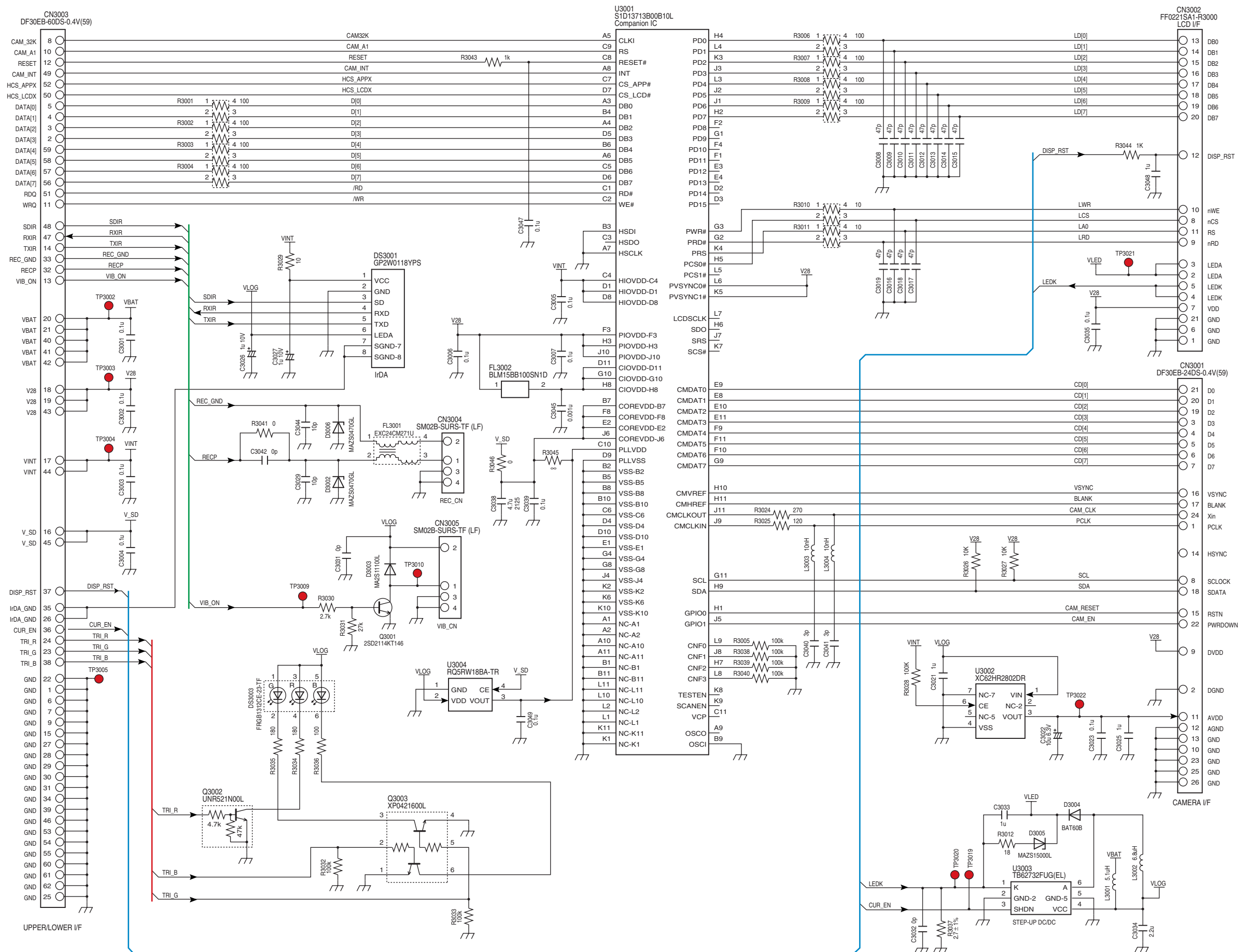

11.4. Circuit Diagram of Hinge

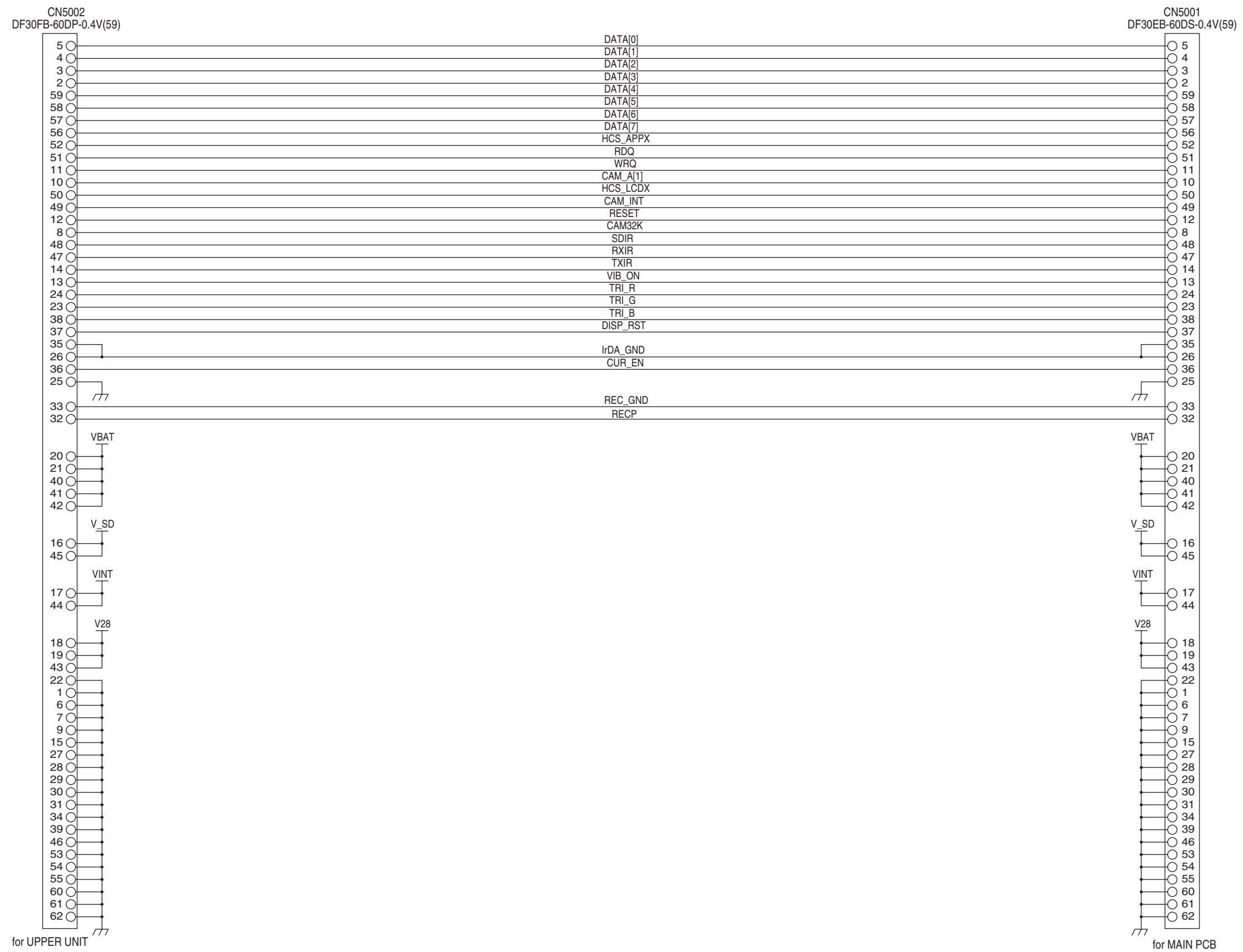

11.5. Circuit Diagram of Keypad

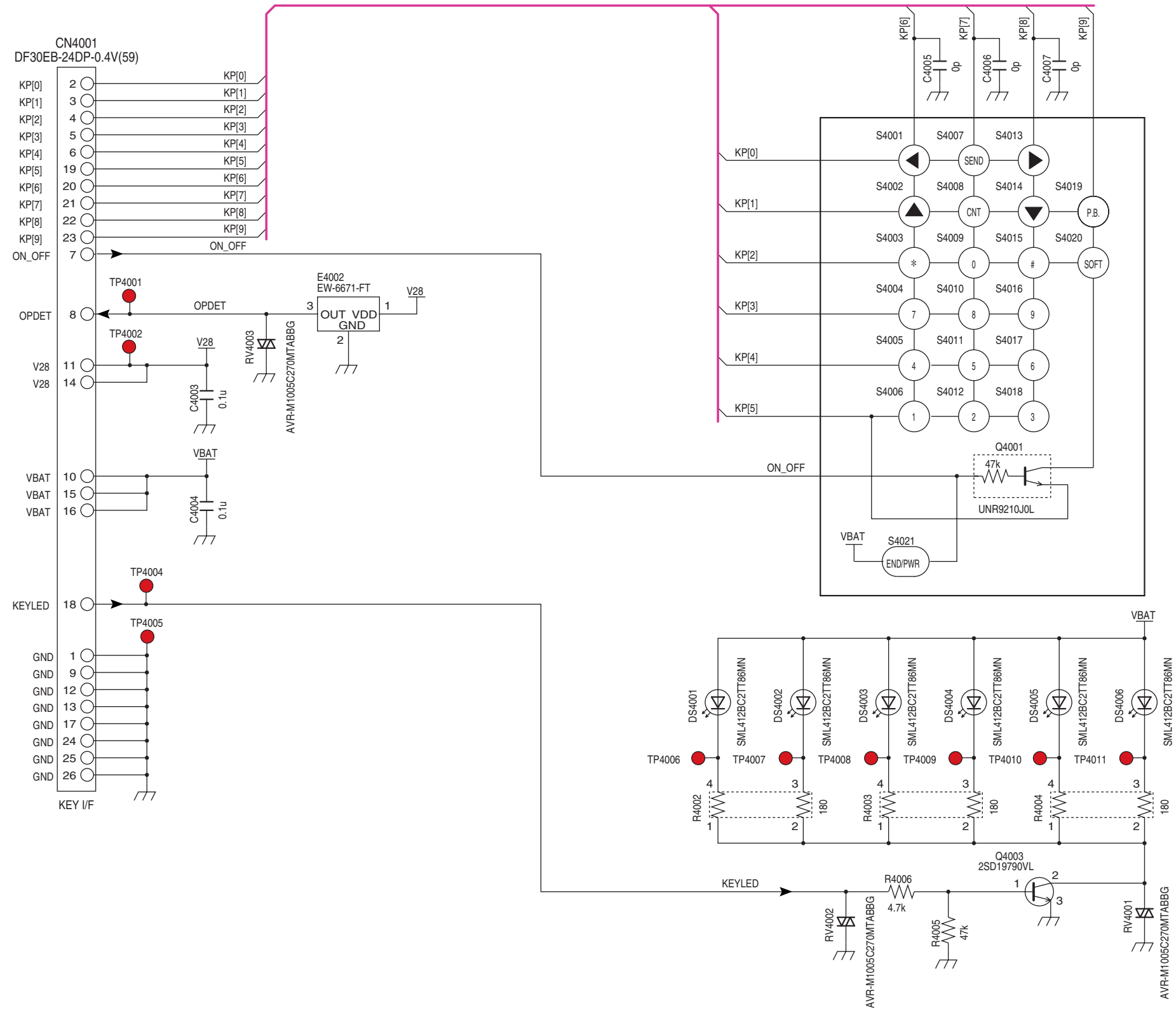

12. LAYOUT DIAGRAMS

12.1. Layout Diagram of Main PCB

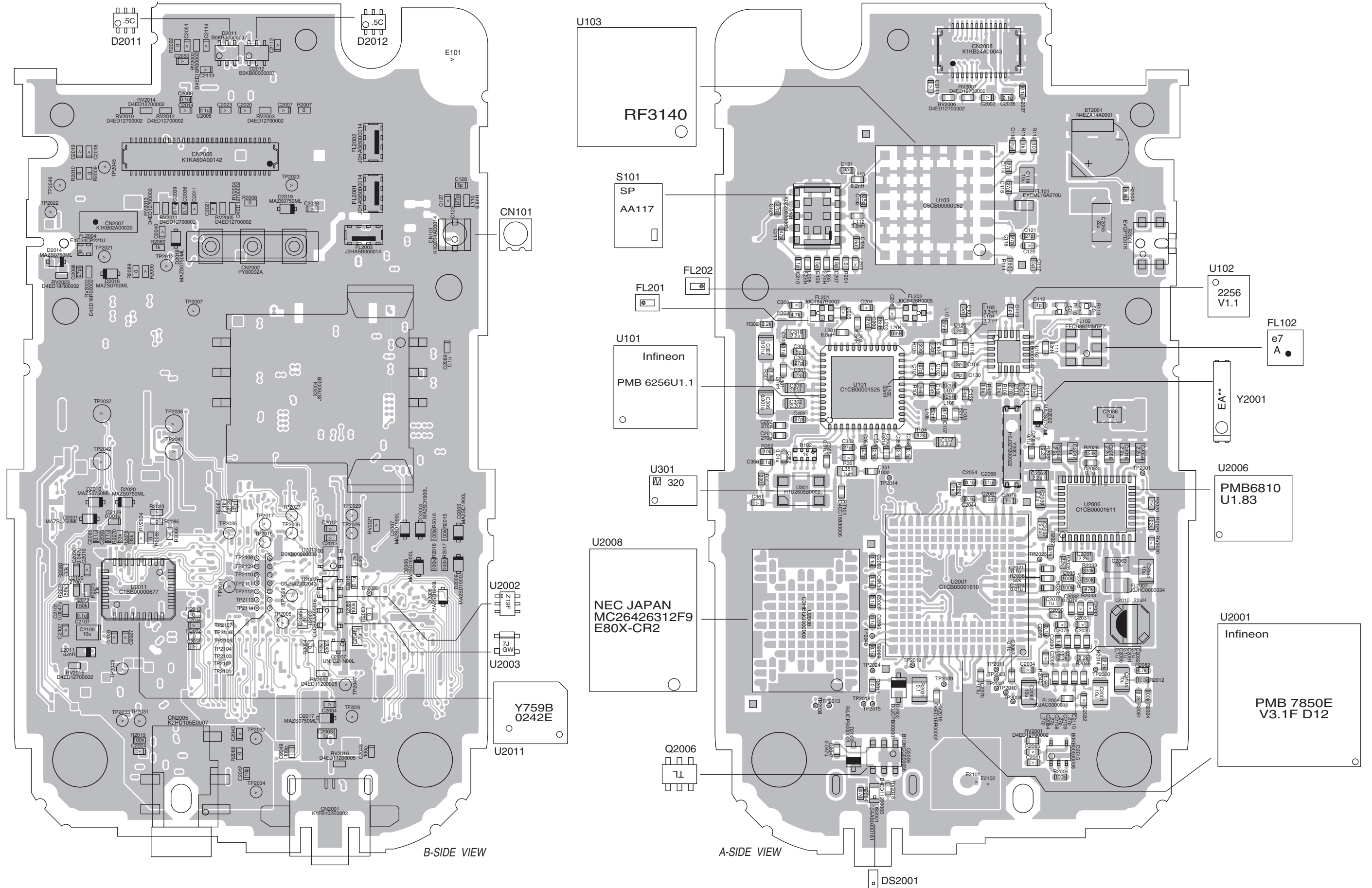

12.3. Layout Diagram of Hinge PCB

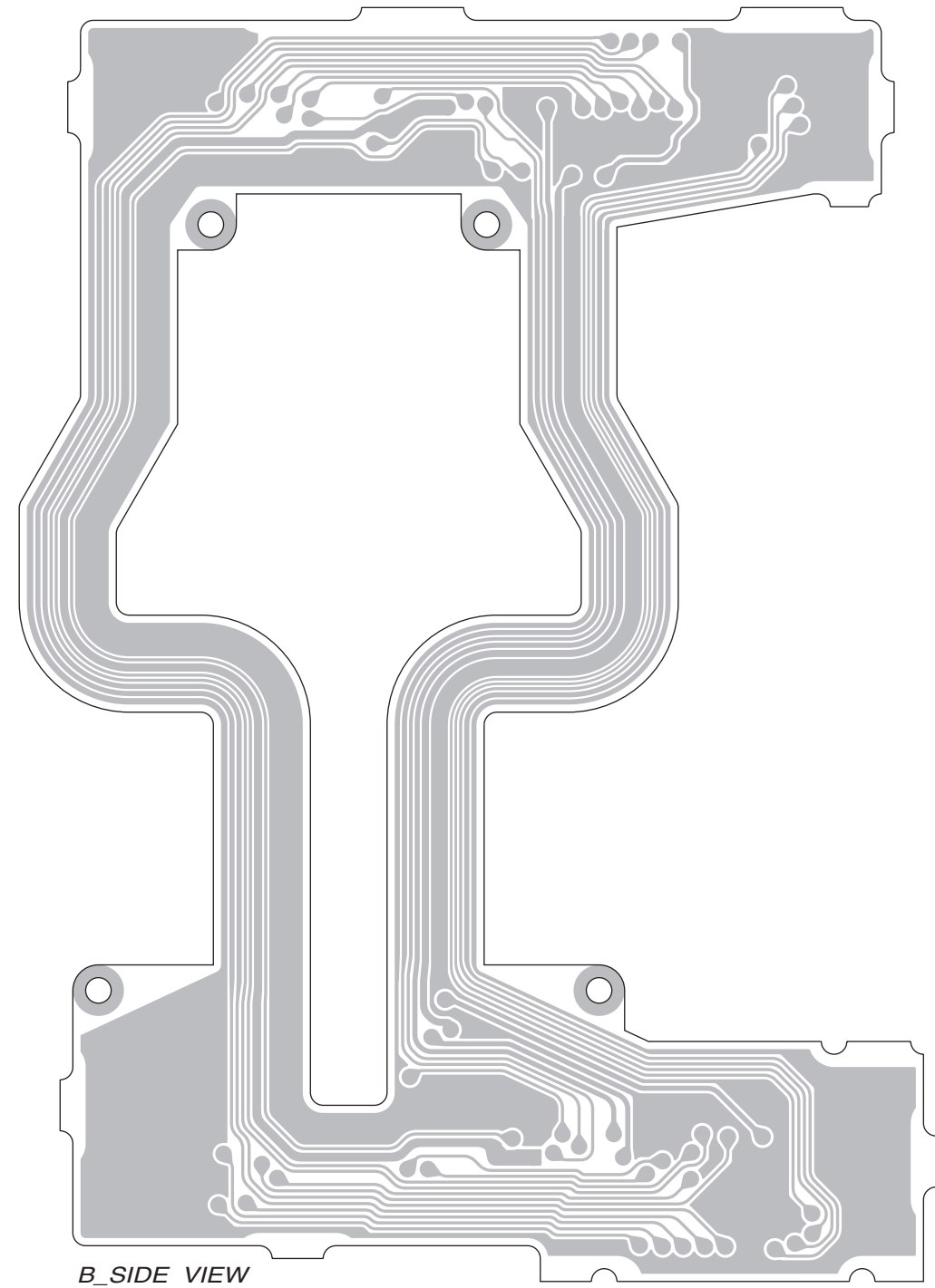
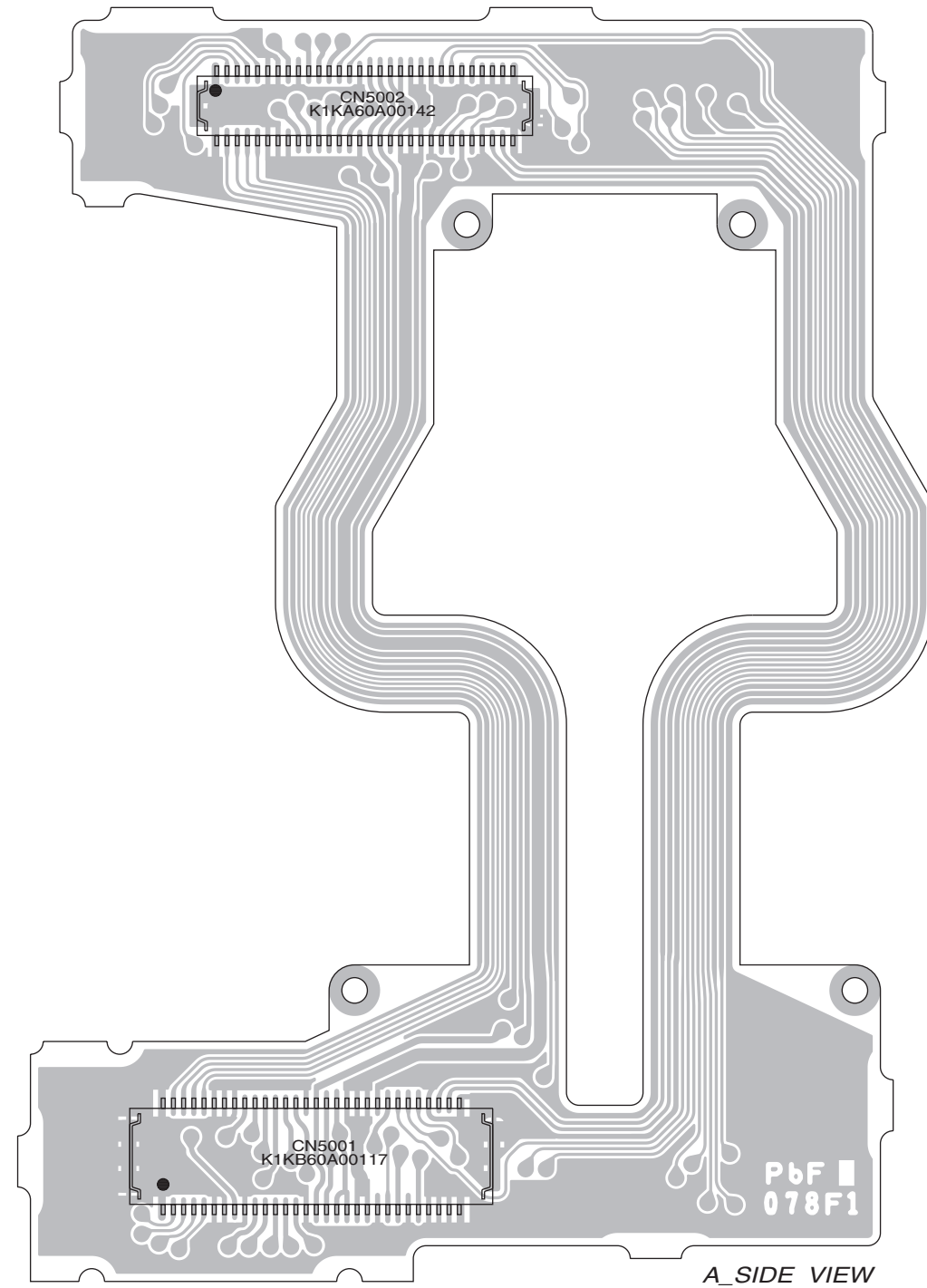

12.4. Layout Diagram of Keypad PCB

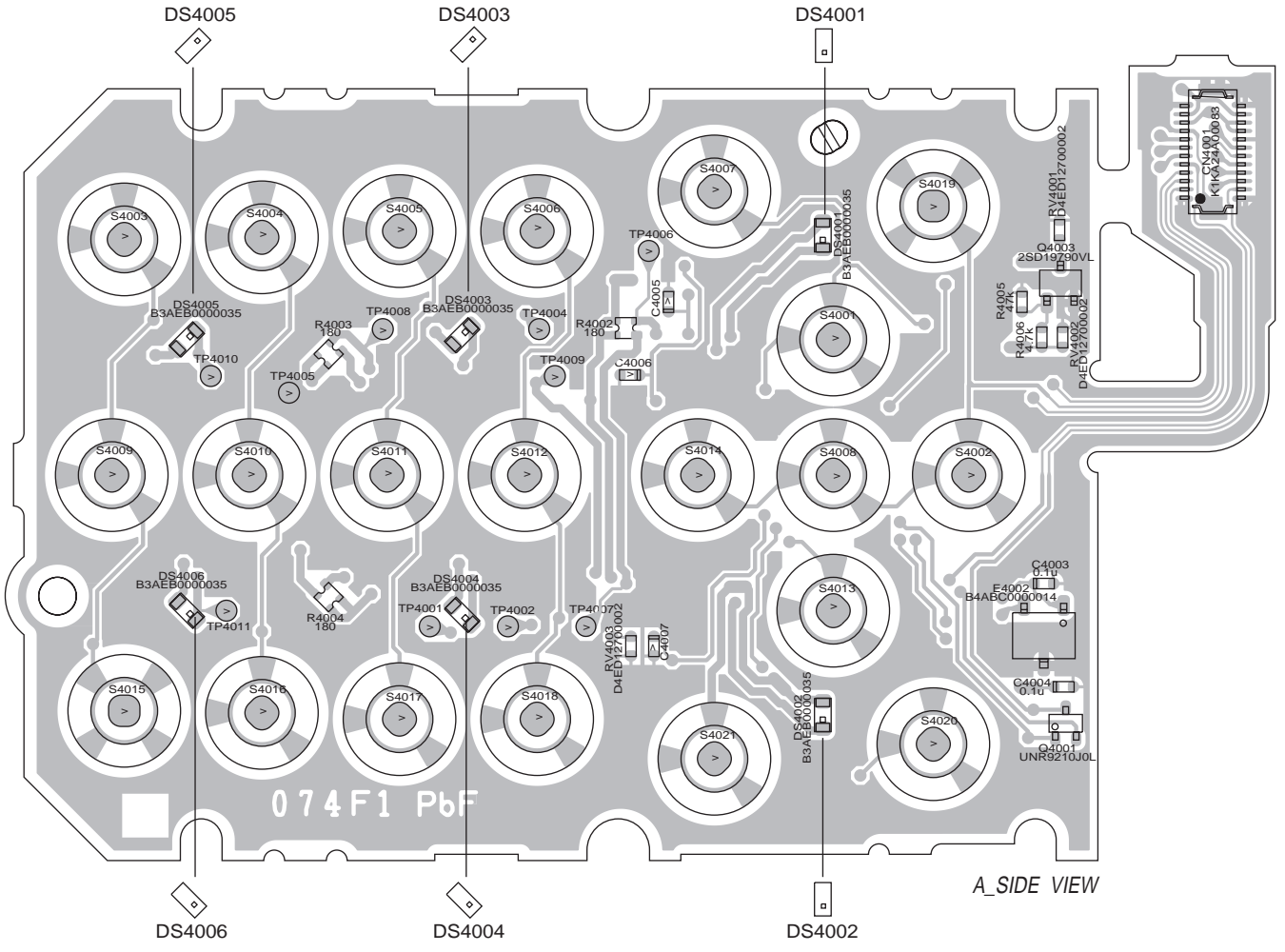

A_SIDE VIEW

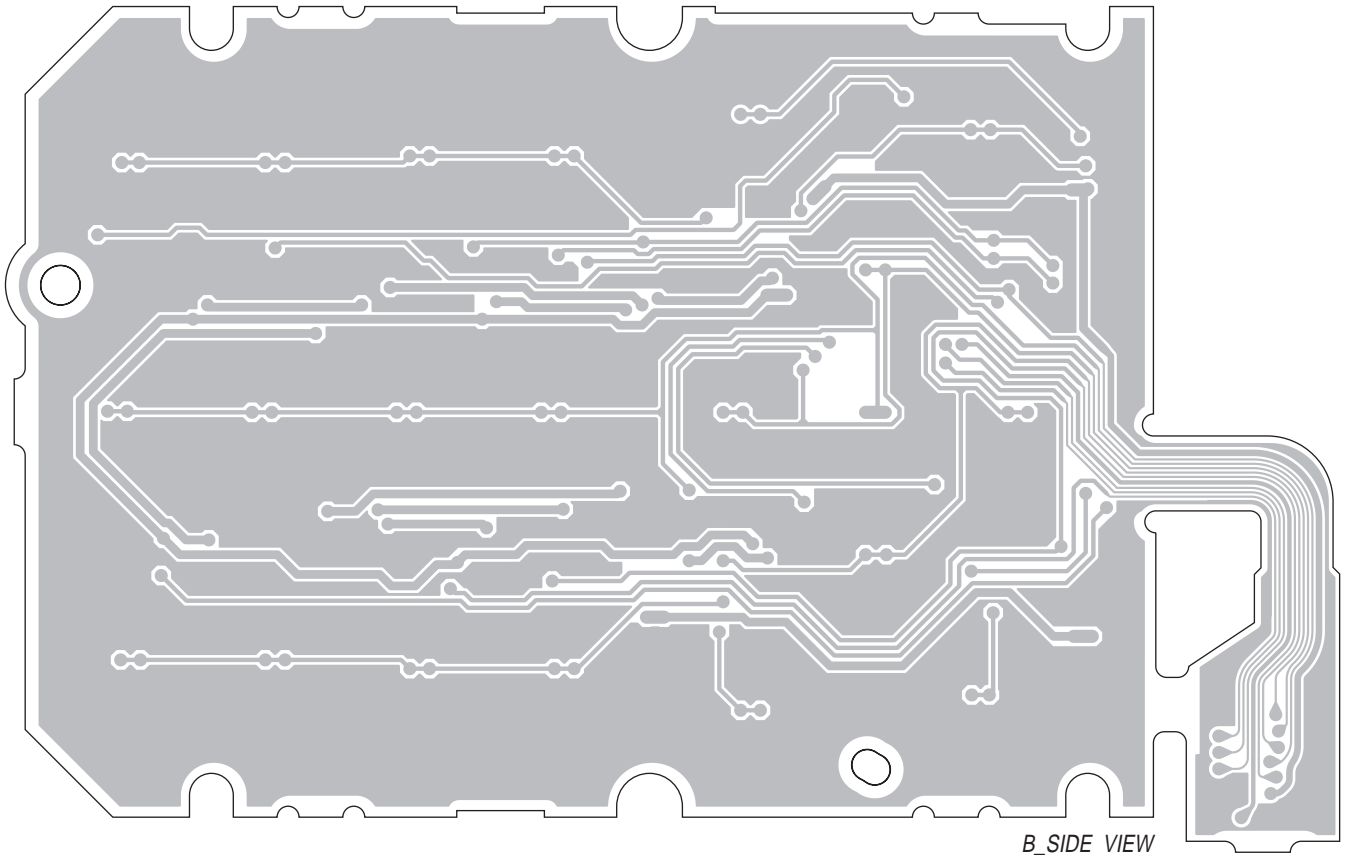

B_SIDE VIEW