

# TXTM8 3G User Guide

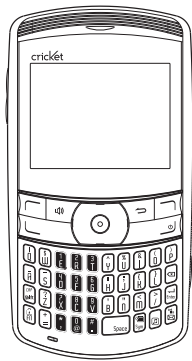

cricket

# Table of contents

<b>Safety</b> .....	<b>3</b>
About your device .....	3
<b>Before using your phone</b> .....	<b>5</b>
Handset description .....	5
Battery usage .....	6
Battery charging .....	6
Battery handling information .....	7
<b>Basic operation</b> .....	<b>8</b>
Using MyHomeScreen .....	8
Accessing the menu map .....	8
Basic functions .....	9
Making a call through the contact list .....	11
Mute/Unmute a call .....	11
<b>Memory function</b> .....	<b>13</b>
Storing a phone number .....	13
Entering letters, numbers & symbols .....	13
<b>Messages</b> .....	<b>14</b>
Send text message .....	14
Send picture message .....	15
Voicemail .....	15
Conversations .....	16
Drafts .....	16
Settings .....	17

<b>Contacts</b> .....	<b>18</b>
My Backup .....	18
Contact list .....	18
Add new entry .....	18
Speed dial .....	19
Group .....	19
Service number .....	20
My phone number .....	20
<b>Multimedia</b> .....	<b>21</b>
Camera .....	21
Video Recorder .....	21
My Pictures .....	22
My Videos .....	23
My Sounds .....	23
My Ringtones .....	24
<b>Music</b> .....	<b>24</b>
Music Player .....	24
Music Files .....	25
My Lists .....	25
<b>Tools</b> .....	<b>25</b>
Schedule .....	25
<b>Bluetooth</b> .....	<b>27</b>
Bluetooth .....	27
<b>Care and maintenance</b> .....	<b>29</b>
<b>Warranty</b> .....	<b>30</b>
One (1) year limited warranty (U.S.) .....	30

<b>Additional safety information .....</b>	<b>36</b>
Small children.....	36
Operating environment.....	36
Medical devices .....	36
Vehicles.....	38
Potentially explosive environments .....	39
Emergency calls.....	40
Certification information (SAR).....	40
Safety information for fixed wireless terminals potentially explosive atmospheres .....	41
Interference to medical devices.....	42
Exposure to RF energy .....	42
Body-worn operation.....	42
FCC compliance information.....	42
U.S.A.	
U.S.Federal communications commission radio frequency interference statement.....	43
FCC hearing-aid compatibility (HAC) regulations for wireless devices...	43

## Safety

Read these simple guidelines. Not following them may be dangerous or illegal. Read the complete user guide for further information.

### Power on safely

Do not power on the device when and where prohibited or when it may cause interference or danger.

### Road safety comes first

Obey all local laws. Always keep your hands free to operate the vehicle while driving. Your first consideration while driving should be road safety.

### Interference

All wireless devices may be susceptible to interference, which could affect performance.

### Turn device off in restricted areas

Follow all warnings. Turn device off in aircraft, near medical equipment, fuel, chemicals, or blasting areas.

### Qualified service

Only qualified personnel may install or repair this product.

### Accessories and batteries

Use only approved accessories. Do not connect incompatible products.

### Water-resistance

Your device is not water-resistant. Keep it dry.

### About your device

The wireless device described in this guide is approved for use on the CDMA 800, 1700, 1900 and 2100 MHz networks. Contact your service provider for more information about networks.

When using the features in this device, obey all laws and respect local customs, privacy and legitimate rights of others, including copyrights.

Copyright protection may prevent some images, music, and other content from being copied, modified, or transferred.

Warning: To use any features in this device, other than the alarm clock, the device must be powered. Do not power the device on when wireless device use may cause interference or danger.

Remember to make back-up copies or keep a written record of all important information stored in your device.

When connecting to any other device, read its user guide for detailed safety instructions. Do not connect incompatible products.

# Before using your phone

## Handset description

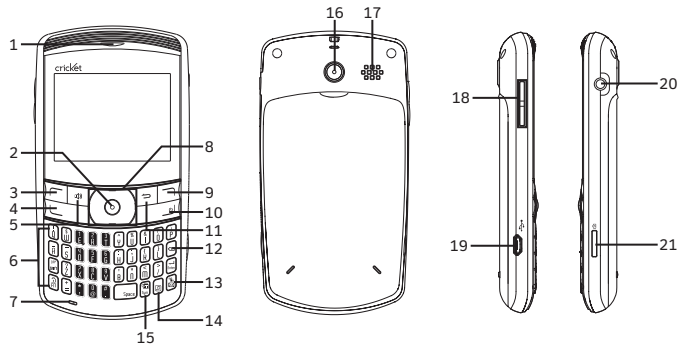

- |                     |                   |                     |
|---------------------|-------------------|---------------------|
| 1. Earpiece         | 8. Navigation key | 15. Schedule key    |
| 2. OK key           | 9. Contacts menu  | 16. Camera lens     |
| 3. Menu key         | 10. End key       | 17. Speaker         |
| 4. Send key         | 11. Back Key      | 18. Side volume key |
| 5. Speakerphone key | 12. Delete key    | 19. Charger port    |
| 6. QWERTY keyboard  | 13. Messages key  | 20. Headset port    |
| 7. Microphone       | 14. Music key     | 21. Camera key      |

## Battery usage

### Battery installation

1. Remove the battery cover from the unit.
2. Slide the battery into the slot located at the bottom of the unit and press until you hear the "Click".

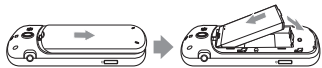

### Battery removal

1. To remove the battery, push down on the top of the battery while inserting your finger into the slot and pulling up from the back of the battery and slide it out.
2. Align the cover tabs with the slots at the top of the device and slide the battery cover back onto the unit.



6 Before using your phone

**note** If the battery is not installed properly, the handset will not turn on and/or the battery may detach during use.

### Battery charging

#### Power connection

1. Plug the AC Charger into a standard outlet.
2. Plug the other end of the AC Charger into the charging port on your phone. The battery must be installed in the device to charge properly.

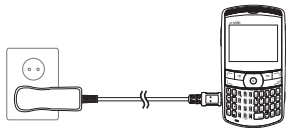

#### **note**

- When you charge the battery with the phone powered off, you will see a charging status screen. You cannot operate the phone until it is powered on.

- Fully charge the battery before use.
- Battery operating time gradually decreases over time.
- If the battery fails to perform normally, you may need to replace the battery.

### Battery handling information

#### Do's

- Only use the battery and charger approved by the manufacturer.
- Only use the battery for its original purpose.
- Try to keep batteries in a temperature between 41°F (5°C) and 95°F (35°C).
- If the battery is stored in temperatures above or below the recommended range, give it time to warm up or cool down before using.
- Completely drain the battery before recharging.
- Store the discharged battery in a cool, dark, and dry place.
- Purchase a new battery when its operating time gradually decreases after fully charging.

- Properly dispose of the battery according to local laws.

#### Don'ts

- Do not attempt to disassemble the battery – it is a sealed unit with no serviceable parts.
- Do not short circuit the battery by carrying it in your pocket or purse with other metallic objects such as coins, clips and pens. This may critically damage the battery.
- Do not leave the battery in hot or cold temperatures. This could significantly reduce the capacity and lifetime of the battery.
- Do not dispose of the battery into a fire.

Before using your phone 7

# Basic operation

## Using MyHomeScreen (widgets)

The MyHomeScreen menu (located along the left hand side of the idle screen display) provides quick access to features like Personalize, Horoscope, Weather, Sports, Stock, Storefront and keeps them organized and easily accessible.

1. To access the MyHomeScreen menu in the idle mode, press the Navigation Key up or down to scroll through the MyHomeScreen Menu or press the OK Key and then press the Navigation Key up or down to scroll thru the widget options.
2. To scroll through the Widget sub options, press the Navigation Key left, right, up or down. Press the OK Key to select an option.
3. To exit MyHomeScreen and return to the idle mode, press the END Key. To exit a widget, press the Back or END Key.

### note

- The default widget Menu items - Personalize, My Account and Storefront - cannot be changed, deleted, or moved.

## Accessing the menu map

### 1. Recent Call

1. All Calls
2. Missed Calls
3. Incoming Calls
4. Outgoing Calls
5. Call Timers

### 2. Messages

1. Send Message
2. Voicemail
3. Conversations
4. Drafts
5. Settings

### 3. Email

### 4. Contacts

1. Contact List
2. Add New Entry
3. Speed Dial
4. Group
5. Service Number
6. My Phone Number

### 5. Browser

### 6. Games & Apps

### 7. Multimedia

1. Camera
2. Video Recorder
3. My Pictures
4. My Videos
5. My Sounds
6. My Ringtones

### 8. Music

1. Music Player
2. Music Files
3. My Lists

### 9. Tools

1. Voice Service
2. Schedule
3. Alarm
4. Memo Pad
5. Calculator
6. World Time
7. Tip Calculator
8. Stop Watch
9. Countdown Timer
10. Unit Converter

### 10. Navigator

### 11. Bluetooth

### 12. Settings

1. Display
2. Sounds
3. Call
4. Security
5. Phone
6. Mass Storage
7. Memory Info
8. Phone Info

## Basic functions

### Making a call

1. Enter a phone number.

note To modify the phone number you have entered :

- To erase one digit at a time press the Delete Key.
  - To erase the entire number, press and hold the Delete Key.
2. Press the SEND Key.

### note

- If “CALL FAILED” appears on the display or the line is busy, press the END Key.
- If you activate the “AUTO RETRY” function, the phone will automatically

retry the number until you select the END Key.

- If “Please Enter Lock Code” appears on the display enter your 4-digit password to unlock your phone.
- The default password is the last 4 digits of your phone number.

3. To end a call, press the END Key.

### Call answer

1. To answer an incoming call, press the SEND Key to answer the incoming call. (Depending on your phone’s settings, you may also answer incoming calls by pressing any key.)

note To reject incoming calls, press the Right Soft Key **Reject** or press the END Key.

2. To end a call, press the END Key.

### Wait/pause feature

Pauses are used for automated systems (i.e., Voicemail, calling cards). Insert a pause after a phone number then enter another group of numbers.

The second set of numbers is dialed automatically after the pause. This feature is useful for dialing systems that require a code.

1. To insert a wait/pause, enter a phone number then press the Right Soft Key **Options**. Select either a Type 'P' ("P" appears) or a Type 'T' ("T" appears).

**note**

- Type 'P': A hard pause stops the calling sequence until further input from you.
  - Type 'T': A pause stopping the calling sequence for two seconds and then automatically sends the remaining digits.
2. Press the SEND Key to dial or Left Soft Key **Save** to save the number.

### 3-way calling

With 3-Way Calling, you can talk to two people at the same time.

1. Enter a number you wish to call then press the SEND Key.
2. Once you have established the

connection, enter the second number you wish to call then press the SEND Key.

3. When you're connected to the second party, press the SEND Key again to begin your 3-Way call.

**note** 3-way calling is a system dependent feature. Please contact your service provider for details.

### Caller ID function

Identifies caller by displaying their phone number. If the caller's name and number are stored in the phone book, their name will appear. This is a system dependent feature. Please contact your service provider for details.

### Call waiting function

Notifies you of an incoming call when you are already on a call by sounding a beep tone and displaying the caller's phone number.

1. To answer another call while on the phone, press the SEND Key. This

places the first call on hold.

To switch back to the first caller, press the SEND Key again.

**note** Call Waiting is a system dependent feature. Please contact your service provider for details.

### Adjusting volume

1. During a call, press Side Volume Scroll Key up or down to adjust the earpiece volume.

### Making a call through the contact list

#### One-touch/two-touch dialing

Ideal for frequently dialed numbers, this feature allows entries in your contact list to be dialed via the keypad with only one or two key presses. In order for One-Touch/Two-Touch Dialing to properly work, it must be enabled.

#### One-touch dialing

- 2-9: Press and hold the corresponding memory number for more than 1 second.

### Two-touch dialing

10-99: Enter the first digit and press and hold the second digit for more than 1 second.

**note**

- If no phone number is stored in the location entered, "Speed dial is empty" will appear on the screen.
- If One Touch Dial is set to Off: Enter the speed dial location number then press the SEND Key.
- Location 1 is reserved for voicemail. Location 2-99 are unassigned. To assign a speed dial location, please see page 19.

### Mute/Unmute a call

1. During a call, press the Left Soft Key **Mute**.
  - **Mute (Unmute):** If you press Mute during a call, the person you are speaking with cannot hear you or any sounds from your side of the conversation. However, you can still hear them.

- To Unmute, press the Left Soft Key **Unmute**.
- The phone will automatically unmute in Emergency Call or Callback Mode.

**During a call**, press the Right Soft Key “Options” for;

- **Voice Memo:** To record a voice memo during a call.
- **Recent Calls:** To select a phone number from your Recent Calls List during a call.
- **Contacts:** To view a phone number from your Contact list during a call.
- **Messages:** To send a text message (SMS) during a call.
- **Bluetooth:** When user is calling with TXTM8 3G mobile phone, user can select Bluetooth in order to call with Bluetooth headset.

### Making an emergency call

The 911 feature puts the phone in the Emergency Call Mode when you dial

the preprogrammed emergency number, 911. It also operates in Lock Mode and outside the service area.

### 911 in lock mode

The 911 call service is available even in Lock Mode.

1. Enter “911”, then press the SEND Key.
2. The call connects.
3. When the call ends, the phone returns to Lock Mode.

### 911 using any available system

1. Enter “911”, then press the SEND Key.
2. The call connects.
3. The phone maintains the Emergency Mode and the phone can receive an incoming call from any available system. However, it cannot make a call while still in Emergency Callback Mode.

## Memory function

### Storing a phone number

The phone book stores up to 1000 entries.

1. Enter phone number then press the Left Soft Key **Save**.
2. Select “New Entry” or “Existing Entry”.
3. If “Existing Entry” is selected, your contact list is displayed. Choose the entry to add the number, then press the OK Key. Select the phone type you are adding from the list, then press the OK. If a phone number is already assigned to the category you selected, press the OK Key **Save**.
4. If “New Entry” is selected, the New entry list appears. Press the Navigation Key up or down to choose the type of Phone you are adding. Enter a name. Press the Navigation Key down to enter information in other fields for the

contact. Fields include “Photo”, “Name”, “Mobile”, “Home”, “Office”, “Fax”, “Other Number”, “Email”, “Ringtone”, “Group”, “Birthday”, “Memo”. Press the OK Key **Save**.

### Entering letters, numbers & symbols

The TXTM8 3G has a fully functional QWERTY keypad that provides a superior typing experience for easy and comfortable input. See following key descriptions on the diagram and corresponding numbered paragraph.

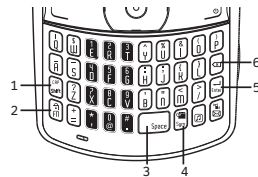

1. Cap/Shift Key: To type upper-case letters, press the CAP/Shift Key and then press one or more letter keys. To type upper-case letters only, press the FN Key and then press

the CAP/Shift Key. The CAP icon will appear on the screen. To return to typing lower-case letters, press the FN Key again. To type an upper-case for the first letter of a word only, simply press the CAP/Shift Key once. Then, the first letter you type will be an upper-case while the rest will be normal letters.

2. FN Key: To type the special character or numbers that appear on the keys, press the FN Key and then press one or more special character or numbers keys. To type special characters or numbers consecutively, use the FN-LOCK mode. To change to the FN-LOCK mode, press the FN Key twice. You can type special characters or numbers only in this mode. To deactivate, press the FN Key again. To type a special character or number for the first letter of a word only, simply press the FN Key once. Then, the first letter you type will be a special character or number while the rest will be normal letters.

3. Space Key: Press the Space Key to type a blank space.
4. Sym Key: Press to open symbols list.
5. Enter Key: Press the Enter Key to insert a line break.
6. Delete Key: Press the Delete Key to delete a character to the left of the text cursor. Press and hold to delete the entire entry.

## Messages

### Send text message

To send a new text message:

1. Press the Left Soft Key **Menu** > **Messages** > **Send Message**.
2. Under “Send To”, input the recipient’s phone number.
  - Press the Right Soft Key **Options**. (Recent Calls, Recent Msg., Contacts, Group Lists)
3. Press the OK Key **Message**. Under “SMS”, input your message.

- Press the Right Soft Key **Options**. (Preset Msg., Add Picture, Add Video, Add Sound, Add vCard, Attach Contact, Preview, Save as Draft, Delivery)
4. Press the OK Key **Recipient**. To send the message, press the Left Soft Key **Send**.

### Send picture message

To send a new picture message:

1. Press the Left Soft Key **Menu** > **Messages** > **Send Message**.
2. Under “Send To”, input the recipient’s phone number.
  - Press the Right Soft Key **Options**. (Recent Calls, Recent Msg., Contacts, Group Lists)
3. Press the OK Key **Message**. Under “SMS”, input your message.
4. Press the Right Soft Key **Options**. Select “Add Picture”, “Add Video”, “Add Sound” or “Add vCard”.
5. Scroll to desired content folder and press the OK Key.

6. Scroll to the desired picture, video or sound, press the Right Soft Key **Select**.
7. Press the OK Key **Recipient**. Under “Send To”, input the recipient’s phone number and subject.
  - Press the Right Soft Key **Options**. (Recent Calls, Recent Msg., Contacts, Group Lists)
8. To send the multimedia message, press the Left Soft Key **Send**.

### Voicemail

Voicemail allows callers to leave voice messages in your voice mailbox, and lets you review, play, and delete your voice messages any time you are in your Carrier’s network coverage area.

### Call voicemail

1. Press the Left Soft Key **Menu** > **Messages** > **Voicemail** > **Call Voicemail**.

To quickly access voicemail, press

and hold the 1 key. Follow voice prompts.

## Details

View last voicemail information.

1. Press the Left Soft Key **Menu** > **Messages** > **Voicemail** > **Details**.

## Clear notification

Delete the voicemail icon.

1. Press the Left Soft Key **Menu** > **Messages** > **Voicemail** > **Clear Notification**.

## Conversations

The Inbox manages received text/picture/video messages and manages sent messages.

1. Press the Left Soft Key **Menu** > **Messages** > **Conversations**.
2. To delete a message, press the Right Soft Key **Options**, and select Erase, then select “Yes” and press the OK Key. To delete all messages, press the Right Soft Key **Options**, and select Erase All, then

- select “Yes” and press the OK Key.
3. To display a message, scroll to the message and press the OK Key. The message is displayed. Press the Right Soft Key **Options** to send the selected message.

- Press the Right Soft Key **Options**. (Edit, Retry Sending, Show Contact, Send Message, Erase, Forward, Erase All)

## Drafts

The Draft folder contains messages that are not yet ready to send. If message composition is interrupted by a voice call or other interrupting event, the text of the current composition is automatically saved in the drafts folder.

1. Press the Left Soft Key **Menu** > **Messages** > **Drafts**.
2. Select a message then press the OK Key.
  - Press the Right Soft Key **Options**. (Edit/Send, Forward, Save Contact, , Multi Check, Erase All)

3. To edit the message. Press the Right Soft Key **Options**. Select “Edit/Send”. Edit the message.
4. Under “Send To”, input the recipient’s phone number.
5. Press the OK Key **Message**. Under “SMS”, input your message.
6. Press the OK Key **Recipient**. To send the message, press the Left Soft Key **Send**.

## Settings

1. Press the Left Soft Key **Menu** > **Messages** > **Settings**.
  - Entry Mode: To set a entry mode. Select “Abc”, “ABC” or “Function Lock”.
  - Notification: To set a notification. Select “Msg. & Icon” or “ICON Only”.
  - Message Reminder: To set a message remind. Select “Off” or “1 Min”.
  - Auto Save: To automatically save a message after sending,

select “Auto Save”, “Prompt” or “Do Not Save”.

- Auto Erase: Automatically erases Inbox messages when new messages arrive. Select “On” or “Off”. Oldest message erased from Inbox automatically when Inbox is full.
- Auto View: To set Auto View. Select “On” or “Off”.
- Auto Retrieve: To set Auto Retrieve. Select “Auto” or “Manual”.
- Callback #: Allows you to input a specific callback number. Callback numbers are used in text messaging so the other party knows how to get back to you. Select “None”, “MDN” or “Custom”.
- Voice Mail #: To set your voicemail number. (Default setting is \*99)
- Signature: To create a signature that can be automatically inserted at the end of a text message. Select “None” or “Custom”. If you

select “Custom”, the signature input screen appears.

- **Msg Receipt:** To set Msg Receipt. Select “On” or “Off”.
- **Preset Messages:** The preset messages are displayed.

2. Press the OK Key to save the setting.

## Contacts

### My Backup

The My Backup application will backup your contact list perform regular updates and download contacts. Please contact your Service Provider for details including associated service costs.

### Contact list

Retrieves an entry by name and calls the primary number by simply pressing the SEND Key. You can review all the entries stored in your Contact list or quickly find an entry

by entering a name or its character string.

1. Press the Left Soft Key **Menu** > **Contacts** > **Contact List**.
2. The list of names in your contacts is displayed alphabetically.
3. Enter a name or its character string or scroll through the list by pressing the Navigation Key up or down.

**note** Selecting My Backup will launch this preloaded application at Games & Apps.

### Add new entry

To add a new entry:

1. Press the Left Soft Key **Menu** > **Contacts** > **Add New Entry**.
2. Fill in the fields as they are selected. Press the Navigation Key up or down to select a field.
  - Phone book fields: Photo, Name, Phone number (Mobile, Home, Office, Fax, Other Number), Email, Ringtone, Group (No Assigned,

Family, Friends, Work), Birthday, Memo

**note** See page 13 for more detailed information about storing a number.

### Speed dial

In idle mode, calls can be placed to numbers stored in speed dial by pressing & holding the location number on the key pad. For a 2-digit location number, press the first number, then press and hold the second number.

**note** Speed Dial must be activated.

1. Press the Left Soft Key **Menu** > **Contacts** > **Speed Dial**.
2. To assign a phone number to a speed dial location, select the speed dial location, then press the OK Key **Assign**. Scroll to the contact number desired and press the OK Key **Assign**.
  - Press the Right Soft Key **Options**. (Msg., Prepend, Erase)

**note** The “Prepend” option allows additional numbers to be added prior to the Contact phone number you are calling. You can prepend the international dialing number, area code or calling card number before the phone number you try to call.

- “Empty” appears if the location is available.
  - Location 1 is reserved for voicemail.
3. Scroll to the contact in the list.
  4. If more than one number exists for the contact, press the Navigation Key left or right to select the phone number for the speed dial location. The Speed Dial number assigned will be displayed to the right of the contact in the contact list.

### Group

Allows you to classify phone entries into groups. Existing groups include No Group, Family, Friends, Work.

## Add new group

1. Press the Left Soft Key **Menu** > **Contacts** > **Group**.
2. Press the Left Soft Key **Add** to add a new group name.
3. Input a new group name.
4. To save it, press the OK Key **OK**.
  - Press the Right Soft Key **Options**. (Ringtone, Add Members, Rename, Erase Group)

## Change group name

1. Press the Left Soft Key **Menu** > **Contacts** > **Group**.
2. Select an existing group name. Only groups you created can be renamed.
3. Press the Right Soft Key **Options**, then scroll to "Rename", press the OK Key.
4. Input a new group name.
5. Press the OK Key **OK** to save the setting.

## Service number

Your Contact list is preprogrammed with contact numbers for various services.

1. Press the Left Soft Key **Menu** > **Contacts** > **Service Number**.
2. Select the number (Info "411" / Cust Svc "611" / Cust Care "\*\*611" / \*Pay "\*\*729") then press the OK Key.
3. Press the SEND Key to call.

## My phone number

Displays your phone number.

1. Press the Left Soft Key **Menu** > **Contacts** > **My Phone Number**.
2. Your phone number will be displayed.

# Multimedia

## Camera

### Take picture

1. Press the Left Soft Key **Menu** > **Multimedia** > **Camera**, or press the Side Camera Key.
  2. Point the camera lens at your subject. You can check the picture framing through the display screen.
    - Zoom - Press the Navigation Key up or down (No zoom at 1600x1200 resolution).
  3. Pressing the Right Soft Key **Options**, you can choose from the following:
    - Mode: Camera, Video
    - Resolution: 1600 x 1200, 1280 x 960, 640 x 480, 320 x 240
    - Self Timer: Off, 2 Seconds, 5 Seconds, 10 Seconds
    - Mirror: Normal, Vertical, Horizontal
    - Quality: Economy, Normal, Fine
    - White Balance: Auto, Sunny,

Cloudy, Fluorescent, Incandescent

- Image Effect: Off, Gray, Negative, Sepia
- Fun Frame: Off, Image1, Image2, Image3, Image4, Image5, Image6, Image7, Image8, Image9
- Settings & Help: Settings, Reset, Help

**note** To view captured images, press the Left Soft Key **Pictures**.

4. Press the Side Camera Key or press the OK Key to take the picture.
5. Picture will be automatically saved.

## Video Recorder

1. Press the Left Soft Key **Menu** > **Multimedia** > **Video Recorder**.
2. Point the camera lens at your subject. You can check the video framing through the display screen.
  - Zoom - Press the Navigation Key up or down.
3. Pressing the Right Soft Key **Options**, you can choose from the

following:

- Mode: Camera, Video
- Resolution: 320 x 240, 176 x 144
- Self Timer: Off
- Mirror: Normal, Vertical, Horizontal
- Quality: Economy, Normal, Fine
- White Balance: Auto, Sunny, Cloudy, Fluorescent, Incandescent
- Image Effect: Off, Gray, Negative, Sepia
- Settings & Help: Settings, Reset, Help

4. Press the OK Key **Rec** or Side Camera Key to take the video.
5. To stop recording, press the OK Key **Stop** or Side Camera Key.
6. Video will be automatically saved.

## My Pictures

In my Images you can view all the images you have taken.

1. Press the Left Soft Key **Menu** > **Multimedia** > **My Pictures**.
2. Press the Navigation Key up, down, left or right to select your

desired images, then press the Right Soft Key **Options**.

3. Select one of the following options:

- Get New: To get new wallpapers and/or screensavers.
- Set As: Assigns image as wallpaper to a contact, main display or front display. (Contacts, Wallpaper, Incoming Calls)
- Erase: To erase a picture stored on your phone.
- Lock: Lock the selected picture.
- Protect: Protect the selected picture.
- Rename: Rename the selected picture.
- Multi Check: To select multiple pictures.
- Erase All: To erase all the pictures in your phone.
- View Type: Select Icon style or List style.
- Picture Info: Displays information about the selected picture.

4. To send via picture message, press the Left Soft Key **Send**.

**note** See page 15 for more detailed information about sending picture messages.

## My Videos

In my videos you can view all the video you have taken.

1. Press the Left Soft Key **Menu** > **Multimedia** > **My Videos**.
2. Press the Navigation Key up, down, left or right to select your desired videos, then press the Right Soft Key **Options**.
3. Select one of the following options:
  - Erase: To erase a video stored on your phone.
  - Lock: Lock the selected video.
  - Protect: Protect the selected video.
  - Rename: Rename the selected video.
  - Multi Check: To select multiple videos.
  - Erase All: To erase all the videos in your phone.

- View Type: Select Icon style or List style.
- Video Info: Displays information about the selected video.

4. To send via video message, press the Left Soft Key **Send**.

## My Sounds

Allows you to record a reminder message that can be up to 4 minutes.

1. Press the Left Soft Key **Menu** > **Multimedia** > **My Sounds**.
2. To record a voice message, press the Left Soft Key "Record".
3. To start recording, press the OK Key **in red**. To stop recording and save, press the OK Key.
4. Enter a name or press the OK Key to save the sound.
  - Press the Right Soft Key **Options**. (Record, Set As, Erase, Protect, Rename, Multi Check, Erase All, Sound Info)

## My Ringtones

This menu displays the list of downloaded ringtones.

1. Press the Left Soft Key **Menu** > **Multimedia** > **My Ringtones**.
2. Scroll through the downloaded ringtones to play the ringtone you want.
  - Get New: To get new ringtones.

**note** Additional charges apply for downloads.

# Music

## Music Player

To access the music player.

1. Press the Left Soft Key **Menu** > **Music** > **Music Player**, or press the Music Key.
2. The music Library screen appears in the display.

### **note**

- Navigation Key up: To play your song random order mode.

- Navigation Key down: To replay the song mode.
  - Navigation Key left: To start the song over again.
  - Navigation Key right: To skip to the next song.
3. Pressing the Right Soft Key **Options**, you can choose from the following:
    - Minimize: To minimize Music Player.
    - Equalizer: Normal, Rock, Jazz, Classic, Pop, Live, Bass
    - Player Theme: Theme 1, Theme 2, Theme 3
    - Song Info: To see detail information - File name, Title, Artist, Album, Genre, File size
  4. Press the OK Key to pause or play the song.
    - Playlist - Press the Left Soft Key.

## Music Files

To access the music files.

1. Press the Left Soft Key **Menu** > **Music** > **Music Files**.
2. All songs appear on the display.
3. Press the OK Key to pause or play the song.

## My Lists

To access the music lists.

1. Press the Left Soft Key **Menu** > **Music** > **My Lists**.
2. The music lists appears in the display.
3. Pressing the Left Soft Key **Add New**, to get new music.
4. Press the OK Key to pause or play the song.

# Tools

## Schedule

Sets an event and reminds you of that event.

### Add new event

1. Press the Left Soft Key **Menu** > **Tools** > **Schedule**.
2. Press the Navigation Key to choose a date in the calendar, then press the Left Soft Key **Add**.
3. The “Add New” screen will be displayed.
  - Title: Enter the event name.
  - Date: You can edit the start date for the event.
  - Start Time: Enter the start time. Press the Left Soft Key for **am** or **pm**.
  - End Time: Enter the end time. Press the Left Soft Key for **am** or **pm**.
  - Contents: Enter any notes for the event.

- Repeat: Press the Navigation Key left or right to select “None”, “Daily”, “Weekly”, “Monthly” or “Yearly”.
  - Duration: You can edit the duration date for the event.
  - Notice: Enter when the alert should sound for the event (On Time, 10 Min Before, 20 Min Before, 1 Hour Before, One Day Before, Off).
  - Ring type: Press the Right Soft Key **List** to select a ringer for the event. Press the OK Key when the ringer is selected.
4. Press the OK Key **Save** to save the event or the Back Key to return to the calendar.
  5. The date of the event will be marked on your calendar.

#### View added events

1. Press the Left Soft Key **Menu** > **Tools** > **Schedule**.
2. Scroll to a date in the calendar and press the OK Key to view the event

for that day.

3. Press the OK Key **View** to see the details for the event.
  - Press the Right Soft Key **Options**. (Add New, Go to Date, Erase Past Entries, Erase Entry, Erase All Entries)

Press the Left Soft Key **Edit** to edit the event, then press the OK Key **Save** to save the event.

#### note

- Schedule/Calendar - To quickly access your schedule/calendar, press the Calendar Key. To scroll thru the schedule/calendar, press the right, left, up or down Navigation Key to a specific date. Press the OK Key to select that date and entry events.

## Bluetooth

### Bluetooth

Using Bluetooth wireless, you can connect the phone wirelessly to other Bluetooth devices, talk hands-free or control the phone remotely. Bluetooth technology allows free wireless connections between all Bluetooth-compliant devices within a range of up to 30 feet. Since the devices communicate using radio waves, they do not need to be in line of sight to each other.

### Bluetooth ON/OFF

To toggle Bluetooth® power On/Off.

1. Press the Left Soft Key **Menu** > **Bluetooth** > **Bluetooth**.
2. Press the Left Soft Key **Turn On**.

note When Bluetooth is set to on, a Bluetooth icon will be displayed in the status bar of the display. The grey icon indicates Bluetooth is on but no Bluetooth devices are connected to

the phone. The blue icon indicates Bluetooth is on and a Bluetooth device is connected to the phone.

### New device

Pairing is the process that allows the handset to locate, establish and register a 1-to-1 connection with the target device.

1. Press the Left Soft Key **Menu** > **Bluetooth** > **Bluetooth** > **Add New Devices**.
2. “Place device you’re connecting to in discoverable mode” will be displayed. Press the OK Key.
3. Press the Right Soft Key **Info**.
4. The handset will automatically enable Bluetooth functionality and search for nearby Bluetooth devices.
5. Devices found will appear in the “Add New” list. Press the Navigation Key up or down to select a device, press the OK Key **Pair**.

- The handset may prompt you for the password. Consult the Bluetooth® accessory (sold separately) instructions for the appropriate password (typically “0000”—4 zeroes). Enter the password, then press the OK Key.
- Once pairing is complete, the device will be listed in My Devices. If the device is connected, a circular arrow icon will appear to the right of the Bluetooth device.

If a Bluetooth device is not connected, scroll to the device and press the OK Key.

#### **note**

- In the My Device list, to disconnect, press “Disconnected”. To reconnect, press the OK Key again.
- When an audio device is connected, you can select another device and the connection is automatically transferred from that audio device to the other one.
- If multiple devices are displayed,

select the device you want to connect.

#### **Settings**

To change Bluetooth settings:

- Press the Left Soft Key **Menu** > **Bluetooth** > **Bluetooth**.
- Press the Right Soft Key **Options**.
  - Name: To edit the Bluetooth® name of your phone.
  - Visibility: To select Shown to All or Hidden.
  - Support Service: To view brief descriptions of the Services supported by the phone: Press the Navigation Key up or down to select one of the following Services, then press the OK Key. (Headset/Hands Free/Stereo/Object Push/File Transfer)
  - Information: Displays the bluetooth information (Name, Type, Status, Address);
- Press the OK Key.

## Care and maintenance

Your device is a product of superior design and craftsmanship and should be treated with care. The following suggestions will help you protect your warranty coverage.

- Keep the device dry. Precipitation, humidity, and all types of liquids or moisture can contain minerals that will corrode electronic circuits. If your device does get wet, remove the battery, and allow the device to dry completely before replacing it.
- Do not use or store the device in dusty, dirty areas. Its moving parts and electronic components can be damaged.
- Do not store the device in hot areas. High temperatures can shorten the life of electronic devices, damage batteries, and warp or melt certain plastics.
- Do not store the device in cold

areas. When the device returns to its normal temperature, moisture can form inside the device and damage electronic circuit boards.

- Do not attempt to open the device other than as instructed in this guide.
- Do not drop, knock, or shake the device. Rough handling can break internal circuit boards and fine mechanics.
- Do not use harsh chemicals, cleaning solvents, or strong detergents to clean the device.
- Do not paint the device. Paint can clog the moving parts and prevent proper operation.
- Use only the supplied or an approved replacement antenna. Unauthorized antennas, modifications, or attachments could damage the device and may violate regulations governing radio devices.
- Use chargers indoors.
- Always create a backup of data you want to keep, such as contacts and

calendar notes.

- To reset the device from time to time for optimum performance, power off the device and remove the battery.

These suggestions apply equally to your device, battery, charger, or any accessory. If the device is not working properly, take it to the nearest authorized service facility for service.

## Warranty

### **One (1) year limited warranty (U.S.)**

For products purchased from Cricket or its authorized dealers Cricket warrants that this device ("Product") is free from defects in material and workmanship that result in Product failure during normal usage, according to the following terms and conditions (the "Limited Warranty"):

1. This Limited Warranty for the Product extends for one (1) year beginning on the date of the

purchase of the Product.

2. The Limited Warranty extends only to the original purchaser ("Consumer") of the Product and is not assignable or transferable to any subsequent purchaser/ end-user.
3. The Limited Warranty extends only to Consumers who purchase the Product from Cricket or its authorized dealers.
4. During the Limited Warranty period, Cricket will repair or replace, at Cricket's sole option, any defective parts, or any parts that will not properly operate for their intended use with new or refurbished replacement items if such repair or replacement is needed because of product malfunction or failure during normal usage. the Limited Warranty does not cover defects in appearance, cosmetic, decorative or structural items, including framing, and any non-operative parts. Cricket's limit of liability

under the Limited Warranty shall be the actual cash value of the Product at the time the Consumer returns the Product for repair, determined by the price paid by the Consumer for the Product less a reasonable amount for usage. Cricket shall not be liable for any other losses or damages. these remedies are the Consumer's exclusive remedies for breach of the Limited Warranty.

5. Upon request from Cricket, the Consumer must prove the date of the original purchase of the Product by a dated bill of sale or dated itemized receipt.
6. The Consumer shall bear the cost of shipping the Product to Cricket. Cricket shall bear the cost of shipping the Product back to the Consumer after the completion of service under this Limited Warranty.
7. The Consumer shall have no coverage or benefits under this Limited Warranty if any of the

following conditions are applicable:

- a. The Product has been subjected to abnormal use, abnormal conditions, improper storage, exposure to moisture or dampness, unauthorized modifications, unauthorized connections, unauthorized repair, misuse, neglect, abuse, accident, alteration, improper installation, or other acts which are not the fault of Cricket, including damage caused by shipping.
- b. The Product has been damaged from external causes such as collision with an object, or from fire, flooding, sand, dirt, windstorm, lightning, earthquake or damage from exposure to weather conditions, an act of God, or battery leakage, theft, blown fuse, or improper use of any electrical source, damage caused by computer or internet viruses, bugs, worms, trojan Horses, cancelbots or damage caused by the connection to

- other products (including but not limited to hardware and software) not recommended for interconnection by Cricket.
- c. The Product serial number plate or the enhancement data code has been removed, defaced or altered.
  - d. The defect or damage was caused by the defective function of the cellular system or by inadequate signal reception by the external antenna, or viruses or other software problems introduced into the Product.
8. Cricket does not warrant uninterrupted or error-free operation of the Product. If a problem develops during the Limited Warranty period, the Consumer shall take the following step-by-step procedure:
    - a. The Consumer shall return the Product to the place of purchase for repair or replacement processing.
    - b. The Consumer shall include a return address, daytime phone number and/ or fax number, complete description of the problem, proof of purchase and service agreement (if applicable). Expenses related to removing the Product from an installation are not covered under this Limited Warranty.
    - c. The Consumer will be billed for any parts or labor charges not covered by this Limited Warranty. The Consumer will be responsible for any expenses related to reinstallation of the Product.
    - d. Cricket will repair the Product under the Limited Warranty within 30 days after receipt of the Product. If Cricket cannot perform repairs covered under this Limited Warranty within 30 days, or after a reasonable number of attempts to repair the same defect, Cricket at its option, will provide a replacement Product or refund the purchase price of the Product less a reasonable amount for usage.
  9. If the Product is returned during the Limited Warranty period, but the problem with the Product is not covered under the terms and conditions of this Limited Warranty, the Consumer will be notified and given an estimate of the charges the Consumer must pay to have the Product repaired, with all shipping charges billed to the Consumer. If the estimate is refused, the Product will be returned freight collect. If the Product is returned after the expiration of the Limited Warranty period, Cricket's normal service policies shall apply and the Consumer will be responsible for all shipping charges.
  9. You (the Consumer) understand that the Product may consist of refurbished equipment that contains used components, some of which have been reprocessed. The used components comply with Product performance and reliability specifications.
  10. Disclaimer of Warranty. EXCEPT AS SET FORTH IN THIS EXPRESS LIMITED WARRANTY, CONSUMER TAKES THE PRODUCT "AS IS", AND CRICKET MAKES NO WARRANTY OR REPRESENTATION AND THEREAFTER NO CONDITIONS, EXPRESS OR IMPLIED, STATUTORY OR OTHERWISE, OF ANY KIND WHATSOEVER WITH RESPECT TO THE PRODUCT, INCLUDING BUT NOT LIMITED TO ANY IMPLIED WARRANTY OF MERCHANTABILITY, OR FITNESS FOR A PARTICULAR PURPOSE OR USE; WARRANTIES OF TITLE OR NON-INFRINGEMENT; DESIGN, CONDITION, QUALITY, OR PERFORMANCE OF THE PRODUCT; THE WORKMANSHIP OF THE PRODUCT OR THE COMPONENTS CONTAINED THEREIN; OR COMPLIANT OF THE PRODUCT WITH THE REQUIREMENTS OF ANY LAW,

RULE, SPECIFICATION OR CONTRACT PERTAINING THERETO.

11. CRICKET SHALL NOT BE LIABLE FOR SPECIAL, INCIDENTAL, PUNITIVE OR CONSEQUENTIAL DAMAGES, INCLUDING BUT NOT LIMITED TO LOSS OF ANTICIPATED BENEFITS OR PROFITS, LOSS OF SAVINGS OR REVENUE, LOSS OF DATA, PUNITIVE DAMAGES, LOSS OF USE OF THE PRODUCT OR ANY ASSOCIATED EQUIPMENT, COST OF CAPITAL, COST OF ANY SUBSTITUTE EQUIPMENT OR FACILITIES, DOWNTIME, THE CLAIMS OF ANY THIRD PARTIES, INCLUDING CUSTOMERS, AND INJURY TO PROPERTY, RESULTING FROM THE PURCHASE OR USE OF THE PRODUCT OR ARISING FROM BREACH OF THE WARRANTY, BREACH OF CONTRACT, NEGLIGENCE, STRICT TORT, OR ANY OTHER LEGAL OR

EQUITABLE THEORY, EVEN IF CRICKET KNEW OF THE LIKELIHOOD OF SUCH DAMAGES. CRICKET SHALL NOT BE LIABLE FOR DELAY IN RENDERING SERVICE UNDER THE LIMITED WARRANTY, OR LOSS OF USE DURING THE PERIOD THAT THE PRODUCT IS BEING REPAIRED. NOTHING CONTAINED IN THE INSTRUCTION MANUAL SHALL BE CONSTRUED TO CREATE AN EXPRESS WARRANTY OF ANY KIND WHATSOEVER WITH RESPECT TO THE PRODUCT. ALL IMPLIED WARRANTIES AND CONDITIONS THAT MAY ARISE BY OPERATION OF LAW, INCLUDING IF APPLICABLE THE IMPLIED WARRANTIES OF MERCHANTABILITY AND FITNESS FOR A PARTICULAR PURPOSE, ARE HEREBY LIMITED TO THE SAME DURATION OF TIME AS THE EXPRESS WRITTEN WARRANTY STATED HEREIN.

12. Some states do not allow

limitation of how long an implied warranty lasts, so the one (1) year warranty limitation may not apply to you (the Consumer). Some states do not allow the exclusion or limitation of incidental and consequential damages, so certain of the above limitations or exclusions may not apply to you (the Consumer). this Limited Warranty gives the Consumer specific legal rights and the Consumer may also have other rights which vary from state to state.

13. Cricket neither assumes nor authorizes any authorized service center or any other person or entity to assume for it any other obligation or liability beyond that which is expressly provided for in this Limited Warranty including the provider or seller of any extended warranty or service agreement.
14. This is the entire warranty between Cricket and the Consumer, and supersedes all

prior and contemporaneous agreements or understandings, oral or written, relating to the Product, and no representation, promise or condition not contained herein shall modify these terms. the agents, employees, distributors, and dealers of Cricket are not authorized to make modifications to this Limited Warranty, or make additional warranties binding on Cricket. accordingly, additional statements such as dealer advertising or presentation, whether oral or written, do not constitute warranties by Cricket and should not be relied upon.

15. This Limited Warranty allocates the risk of failure of the Product between the Consumer and Cricket. The allocation is recognized by the Consumer and is reflected in the purchase price.
16. IF ANY PORTION OF THIS LIMITED WARRANTY IS HELD ILLEGAL OR UNENFORCEABLE

BY REASON OF ANY LAW, SUCH PARTIAL ILLEGALITY OR UNENFORCEABILITY SHALL NOT AFFECT THE ENFORCEABILITY FOR THE REMAINDER OF THIS LIMITED WARRANTY WHICH PURCHASER ACKNOWLEDGES IS AND WILL ALWAYS BE CONSTRUED TO BE LIMITED BY ITS TERMS OR AS LIMITED AS THE LAW PERMITS.

## Additional safety information

### Small children

Your device and its enhancements may contain small parts. Keep them out of the reach of small children.

### Operating environment

This device meets RF exposure guidelines when used either in the normal use position against the ear or when positioned at least 2 centimeters (4/5 inches) away from

the body. When a carry case, belt clip, or holder is used for body-worn operation, it should not contain metal and should position the device the above-stated distance from your body.

To transmit data files or messages, this device requires a quality connection to the network. In some cases, transmission of data files or messages may be delayed until such a connection is available. Ensure the above separation distance instructions are followed until the transmission is completed.

Parts of the device are magnetic. Metallic materials may be attracted to the device. Do not place credit cards or other magnetic storage media near the device, because information stored on them may be erased.

### Medical devices

Operation of any radio transmitting equipment, including wireless devices, may interfere with the functionality of inadequately

protected medical devices. Consult a physician or the manufacturer of the medical device to determine if they are adequately shielded from external RF energy or if you have any questions. Switch off your device in health care facilities when any regulations posted in these areas instruct you to do so. Hospitals or health care facilities may be using equipment that could be sensitive to external RF energy.

### Implanted medical devices

Manufacturers of medical devices recommend that a minimum separation of 15.3 centimeters (6 inches) should be maintained between a wireless device and an implanted medical device, such as a pacemaker or implanted cardioverter defibrillator, to avoid potential interference with the medical device. Persons who have such devices should:

- Always keep the wireless device

more than 15.3 centimeters (6 inches) from the medical device when the wireless device is turned on.

- Not carry the wireless device in a breast pocket.
- Hold the wireless device to the ear opposite the medical device to minimize the potential for interference.
- Turn the wireless device off immediately if there is any reason to suspect that interference is taking place.
- Read and follow the directions from the manufacturer of their implanted medical device.

If have any questions about using your wireless device with an implanted medical device, consult your health care provider.

### Hearing aids

Some digital wireless devices may interfere with some hearing aids. If

interference occurs, consult your service provider.

### Hearing aid compatibility

Your mobile device model complies with FCC rules governing hearing aid compatibility. These rules require an M3 microphone or higher value. The M-value, shown on the device box, refers to lower radio frequency (RF) emissions. A higher M-value generally indicates that a device model has a lower RF emissions level, which may improve the likelihood that the device will operate with certain hearing aids. Some hearing aids are more immune than others to interference. Please consult your hearing health professional to determine the M-rating of your hearing aid and whether your hearing aid will work with this device.

This device includes a setting for direct connection to telecoil equipped hearing aids. When both the telecoil hearing aid (T switch)

and the phone telecoil are activated, using the device with the aided ear will provide a direct connection for audio through your hearing aid. The quality of sound depends on the type of hearing aid used. You should test the device with the telecoil setting activated to determine whether your audio performance improves. Using the telecoil hearing-aid setting consumes additional battery power.

More information on accessibility can be found at.

### Vehicles

RF signals may affect improperly installed or inadequately shielded electronic systems in motor vehicles such as electronic fuel injection systems, electronic antiskid (antilock) braking systems, electronic speed control systems, and air bag systems. For more information, check with the manufacturer, or its representative, of your vehicle or any equipment that has been added.

Only qualified personnel should

service the device or install the device in a vehicle. Faulty installation or service may be dangerous and may invalidate any warranty that may apply to the device. Check regularly that all wireless device equipment in your vehicle is mounted and operating properly. Do not store or carry flammable liquids, gases, or explosive materials in the same compartment as the device, its parts, or enhancements. For vehicles equipped with an air bag, remember that air bags inflate with great force. Do not place objects, including installed or portable wireless equipment in the area over the air bag or in the air bag deployment area.

If in-vehicle wireless equipment is improperly installed and the air bag inflates, serious injury could result.

Using your device while flying in aircraft is prohibited. Switch off your device before boarding an aircraft. The use of wireless teledevices in

an aircraft may be dangerous to the operation of the aircraft, disrupt the wireless telephone network, and may be illegal.

### Potentially explosive environments

Switch off your device when in any area with a potentially explosive atmosphere, and obey all signs and instructions. Potentially explosive atmospheres include areas where you would normally be advised to turn off your vehicle engine. Sparks in such areas could cause an explosion or fire resulting in bodily injury or even death. Switch off the device at refueling points such as near gas pumps at service stations. Observe restrictions on the use of radio equipment in fuel depots, storage, and distribution areas; chemical plants; or where blasting operations are in progress. Areas with a potentially explosive atmosphere are often, but not always, clearly marked. They include below deck on boats, chemical transfer

or storage facilities and areas where the air contains chemicals or particles such as grain, dust, or metal powders. You should check with the manufacturers of vehicles using liquefied petroleum gas (such as propane or butane) to determine if this device can be safely used in their vicinity.

### **Emergency calls**

Important: This device operates using radio signals, wireless networks, landline networks, and user-programmed functions.

Connections in all conditions cannot be guaranteed. You should never rely solely on any wireless device for essential communications like medical emergencies.

To make an emergency call:

1. If the device is not on, switch it on. Check for adequate signal strength. Depending on your device, you may also need to complete the following:
  - Remove certain call restrictions

you have activated in your device.

2. Press the END Key as many times as needed to clear the display and ready the device for calls.
3. Enter the official emergency number for your present location. Emergency numbers vary by location.
4. Press the SEND Key.

When making an emergency call, give all the necessary information as accurately as possible. Your wireless device may be the only means of communication at the scene of an accident. Do not end the call until given permission to do so.

### **Certification information (SAR)**

This mobile device meets guidelines for exposure to radio waves.

Your mobile device is a radio transmitter and receiver. It is designed not to exceed the limits for exposure to radio waves recommended by international

guidelines. These guidelines were developed by the independent scientific organization ICNIRP and include safety margins designed to assure the protection of all persons, regardless of age and health.

The exposure guidelines for mobile devices employ a unit of measurement known as the Specific Absorption Rate or SAR. The SAR limit stated in the ICNIRP guidelines is 1.6 watts/kilogram (W/kg) averaged over 1 grams of tissue. Tests for SAR are conducted using standard operating positions with the device transmitting at its highest certified power level in all tested frequency bands. The actual SAR level of an operating device can be below the maximum value because the device is designed to use only the power required to reach the network. That amount changes depending on a number of factors such as how close you are to a network base station.

Use of device accessories and

enhancements may result in different SAR values. SAR values may vary depending on national reporting and testing requirements and the network band.

Your mobile device is also designed to meet the requirements for exposure to radio waves established by the Federal Communications Commission (USA) and Industry Canada. These requirements set a SAR limit of 1.6 W/kg averaged over one gram of tissue. The highest SAR value reported under this standard during product certification for use at the ear is 1.13W/Kg and when properly worn on the body is 0.443W/Kg.

### **SAFETY INFORMATION FOR FIXED WIRELESS TERMINALS POTENTIALLY EXPLOSIVE ATMOSPHERES**

Turn your phone OFF when in any area with a potentially explosive atmosphere and obey all signs and instructions. Sparks in such areas could cause an explosion or fire

resulting in bodily injury or even death.

## **INTERFERENCE TO MEDICAL DEVICES**

Certain electronic equipment may be shielded against RF signal from your wireless phone. (pacemakers, Hearing Aids, and so on) Turn your phone OFF in health care facilities when any regulations posted in these areas instruct you to do so. RF signals may affect improperly installed or inadequately shielded electronic system in motor vehicles.

## **EXPOSURE TO RF ENERGY**

Use only the supplied or an approved replacement antenna. Do not touch the antenna unnecessarily when the phone is in use. Do not move the antenna close to, or touching any exposed part of the body when making a call.

## **BODY-WORN OPERATION**

This device was tested for typical body-worn operations with the back

of the phone kept 2.0 cm from the body. To maintain compliance with FCC RF exposure requirements, use only belt-clips, holsters or similar accessories that maintain 2.0 cm separation distance between the user's body and the back of the phone, including the antenna. The use of belt-clips, holsters and similar accessories should not contain metallic components in its assembly. The use of accessories that do not satisfy these requirements may not comply with FCC RF exposure requirements, and should be avoided. For more information about RF exposure, please visit the FCC website at [www.fcc.gov](http://www.fcc.gov).

## **FCC compliance information**

This device complies with Part 15 of FCC Rules. Operation is subject to the following two conditions:

- (1) This device may not cause harmful interference, and
- (2) This device must accept any interference received.

Including interference that may cause undesired operation.

## **U.S.A.**

## **U.S.FEDERAL COMMUNICATIONS COMMISSION RADIO FREQUENCY INTERFERENCE STATEMENT**

### **INFORMATION TO THE USER**

**note** This equipment has been tested and found to comply with the limits for a Class B digital device pursuant to Part 15 of the FCC Rules. These limits are designed to provide reasonable protection against harmful Interference in a residential installation. This equipment generates, uses, and can radiate radio frequency energy and, if Not installed and used in accordance with the instructions, may cause harmful Interference to radio communications. However, there is no guarantee that interference will not occur in a particular Installation.

If this equipment does cause harmful interference to radio or television reception, which can be determined

by turning the equipment off and on, the user is encouraged to try to correct the interference by one or more of the following measures:

- \*- Reorient or relocate the receiving antenna. Increase the separation between the equipment and receiver.
- \*- Connect the equipment into an outlet of a circuit different from that to which the receiver is connected.
- \*- Consult the dealer or an experienced radio/TV technician for assistance.

Changes or modification not expressly approved by the party responsible for Compliance could void the user's authority to operate the equipment. Connecting of peripherals requires the use of grounded shielded signal cables.

## **FCC hearing-aid compatibility (HAC) regulations for wireless devices**

On July 10, 2003, the U.S. Federal

Communications Commission (FCC) Report and Order in WT Docket 01-309 modified the exception of wireless phones under the Hearing Aid Compatibility Act of 1988 (HAC Act) to require digital wireless phones be compatible with hearing-aids. The intent of the HAC Act is to ensure reasonable access to telecommunications services for persons with hearing disabilities. While some wireless phones are used near some hearing devices (hearing aids and cochlear implants), users may detect a buzzing, humming, or whining noise. Some hearing devices are more immune than others to this interference noise, and phones also vary in the amount of interference they generate. The wireless telephone industry has developed a rating system for wireless phones, to assist hearing device users find phones that may be compatible with their hearing devices. Not all phones have been rated. Phones that are rated have the

rating on their box or a label located on the box. The ratings are not guarantees. Results will vary depending on the user's hearing device and hearing loss. If your hearing device happens to be vulnerable to interference, you may not be able to use a rated phone successfully. Trying out the phone with your hearing device is the best way to evaluate it for your personal needs.

**M-Ratings:** Phones rated M3 or M4 meet FCC requirements and are likely to generate less

interference to hearing devices than phones that are not labeled. M4 is the better/higher of the two ratings. Hearing devices may also be rated. Your hearing device manufacturer or hearing health professional may help you find this rating. Higher ratings mean that the hearing device is relatively immune to interference noise. The hearing aid and wireless



phone rating values are then added together. A sum of 5 is considered acceptable for normal use. A sum of 6 is considered for best use. In the above example, if a hearing aid meets the M2 level rating and the wireless phone meets the M3 level rating, the sum of the two values equal M5. This should provide the hearing aid user with “normal usage” while using their hearing aid with the particular wireless phone. “Normal usage” in this context is defined as a signal quality that is acceptable for normal operation. The M mark is intended to be synonymous with the U mark. The T mark is intended to be synonymous with the UT mark. The M and T marks are recommended by the Alliance for Telecommunications Industries Solutions (ATIS). The U and UT marks are referenced in Section 20.19 of the FCC Rules. The HAC rating and measurement procedure are described in the American National Standards Institute (ANSI) C63.19 standard.

