

SAMSUNG

GSM TELEPHONE SGH-J210

SERVICE *Manual*

GSM TELEPHONE



CONTENTS

1. Safety Precautions
2. Specification
3. Product Function
4. Array course control
5. Exploded View and Parts List
6. Main Electrical Parts List
7. Block Diagrams
8. PCB Diagrams
9. Flow Chart of Troubleshooting
10. Reference data
11. Disassembly and Assembly Instructions

**SAMSUNG
ELECTRONICS**



GSPN (Global Service Partner Network)

Country	Web Site
North America	service.samsungportal.com
Latin America	latin.samsungportal.com
CIS	cis.samsungportal.com
Europe	europe.samsungportal.com
China	china.samsungportal.com
Asia	asia.samsungportal.com
Mideast & Africa	mea.samsungportal.com

1. Safety Precautions

1-1. Repair Precaution

- Repair in Shield Box, during detailed tuning.
Take specially care of tuning or test,
because specificity of cellular phone is sensitive for surrounding interference(RF noise).
- Be careful to use a kind of magnetic object or tool,
because performance of parts is damaged by the influence of magnetic force.
- Surely use a standard screwdriver when you disassemble this product,
otherwise screw will be worn away.
- Use a thicken twisted wire when you measure level.
A thicken twisted wire has low resistance, therefore error of measurement is few.
- Repair after separate Test Pack and Set because for short danger (for example an
overcurrent and furious flames of parts etc) when you repair board in condition of
connecting Test Pack and tuning on.
- Take specially care of soldering, because Land of PCB is small and weak in heat.
- Surely tune on/off while using AC power plug, because a repair of battery charger is
dangerous when tuning ON/OFF PBA and Connector after disassembling charger.
- Don't use as you pleases after change other material than replacement registered on SEC System.
Otherwise engineer in charge isn't charged with problem that you don't keep this rules.

1-2. ESD(Electrostatically Sensitive Devices) Precaution

Several semiconductor may be damaged easily by static electricity. Such parts are called by ESD (Electrostatically Sensitive Devices), for example IC,BGA chip etc. Read Precaution below.

You can prevent from ESD damage by static electricity.

- Remove static electricity remained your body before you touch semiconductor or parts with semiconductor. There are ways that you touch an earthed place or wear static electricity prevention string on wrist.
- Use earthed soldering steel when you connect or disconnect ESD.
- Use soldering removing tool to break static electricity. , otherwise ESD will be damaged by static electricity.
- Don't unpack until you set up ESD on product. Because most of ESD are packed by box and aluminum plate to have conductive power,they are prevented from static electricity.
- You must maintain electric contact between ESD and place due to be set up until ESD is connected completely to the proper place or a circuit board.

2. Specification

2-1. GSM General Specification

	GSM900 Phase 1	EGSM 900 Phase 2	DCS1800 Phase 1	PCS1900
Freq. Band[MHz] Uplink/Downlink	890~915 935~960	880~915 925~960	1710~1785 1805~1880	1850~1910 1930~1990
ARFCN range	1~124	0~124 & 975~1023	512~885	512~810
Tx/Rx spacing	45MHz	45MHz	95MHz	80MHz
Mod. Bit rate/ Bit Period	270.833kbps 3.692us	270.833kbps 3.692us	270.833kbps 3.692us	270.833kbps 3.692us
Time Slot Period/Frame Period	576.9us 4.615ms	576.9us 4.615ms	576.9us 4.615ms	576.9us 4.615ms
Modulation	0.3GMSK	0.3GMSK	0.3GMSK	0.3GMSK
MS Power	33dBm~5dBm	33dBm~5dBm	30dBm~0dBm	30dBm~0dBm
Power Class	5pcl ~ 19pcl	5pcl ~ 19pcl	0pcl ~ 15pcl	0pcl ~ 15pcl
Sensitivity	-102dBm	-102dBm	-100dBm	-100dBm
TDMA Mux	8	8	8	8
Cell Radius	35Km	35Km	2Km	-

2-2. GSM Tx Power Class

TX Power control level	GSM900	TX Power control level	DCS1800	TX Power control level	PCS1900
5	33±2 dBm	0	30±3 dBm	0	30±3 dBm
6	31±2 dBm	1	28±3 dBm	1	28±3 dBm
7	29±2 dBm	2	26±3 dBm	2	26±3 dBm
8	27±2 dBm	3	24±3 dBm	3	24±3 dBm
9	25±2 dBm	4	22±3 dBm	4	22±3 dBm
10	23±2 dBm	5	20±3 dBm	5	20±3 dBm
11	21±2 dBm	6	18±3 dBm	6	18±3 dBm
12	19±2 dBm	7	16±3 dBm	7	16±3 dBm
13	17±2 dBm	8	14±3 dBm	8	14±3 dBm
14	15±2 dBm	9	12±4 dBm	9	12±4 dBm
15	13±2 dBm	10	10±4 dBm	10	10±4 dBm
16	11±3 dBm	11	8±4dBm	11	8±4dBm
17	9±3dBm	12	6±4 dBm	12	6±4 dBm
18	7±3 dBm	13	4±4 dBm	13	4±4 dBm
19	5±3 dBm	14	2±5 dBm	14	2±5 dBm
		15	0±5 dBm	15	0±5 dBm

3. Product Function

Main Function

- Simple and modern bar design
- Music oriented function with loud speaker
- 2 Mega-pixel Camera
- Extended Memory (MicroSD slot)
- Bluetooth v2.0 / USB v2.0
- FM radio (FM radio recording 기능: MP3 format 지원)
- WAP 2.0 / Java MIDP 2.0
- Speaker Phone Function
- MP3, AAC+, MP4, 3GPP Decoding (Offline mode)
- Video recording & Messaging
- Mobile Tracker, My Menu, Living world

4. Array course control

4-1. Software Adjustments

Test Jig (GH80-03306A)



Jig Cable (GH80-00836A)1.5M
(GH80-00834A)0.4M



Serial Cable(CSA LL64151-A)



Power Supply Cable



RF CABLE (GH39-00397A)

4-2. Software Downloading

4-2-1. Pre-requisite for Downloading

- Downloader Program([OneNAND Downloder V1.4 Lite For PNX5230.exe](#))
- J210 Mobile Phone
- Data Cable
- Binary file, TFS file

4-2-2. S/W Downloader Program

- Load the binary download program by executing the ["OneNAND Downloder V1.4 Lite For PNX5230.exe"](#)

1. Select the connected serial port and the rate of speed
2. Select the check box, the mode you want to download.
 - if the binary file wanted, check only 'BIN'
 - if the tfs file wanted, check only 'TFS'
 - if all the files wanted, check 'BIN+TFS'

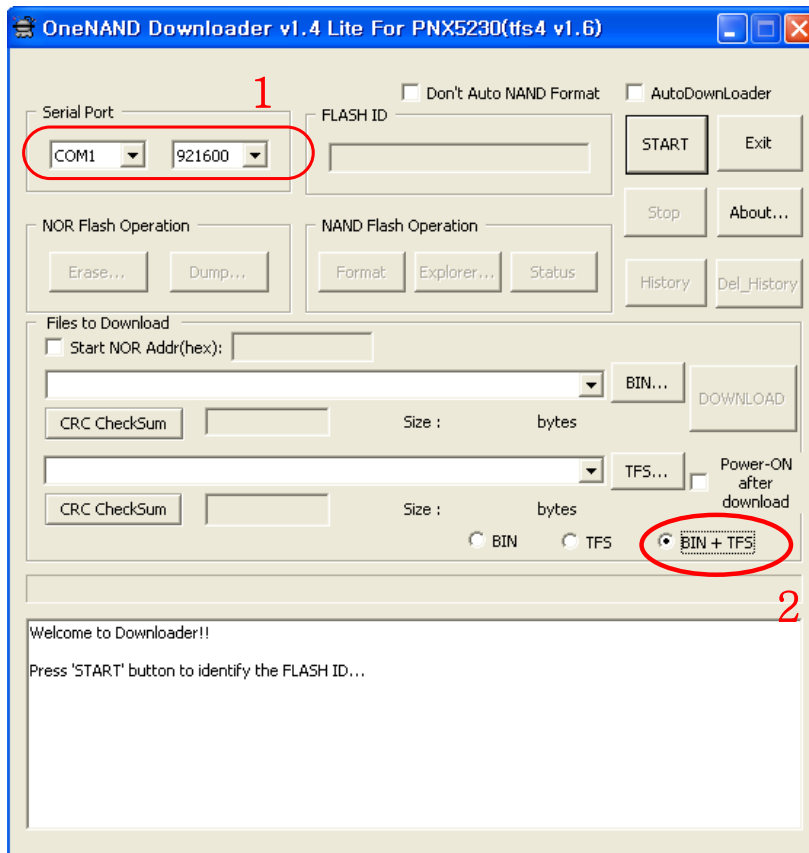

3. Select the file(s) what you want to download

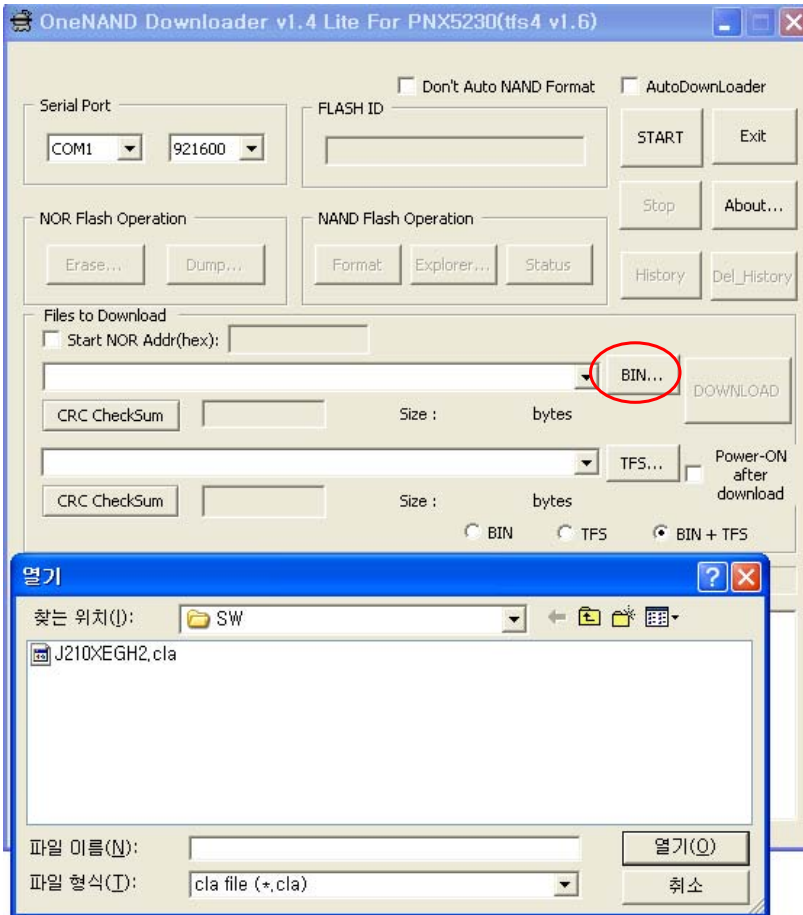

5. Exploded View and Parts List

5-1. Cellular phone Exploded View

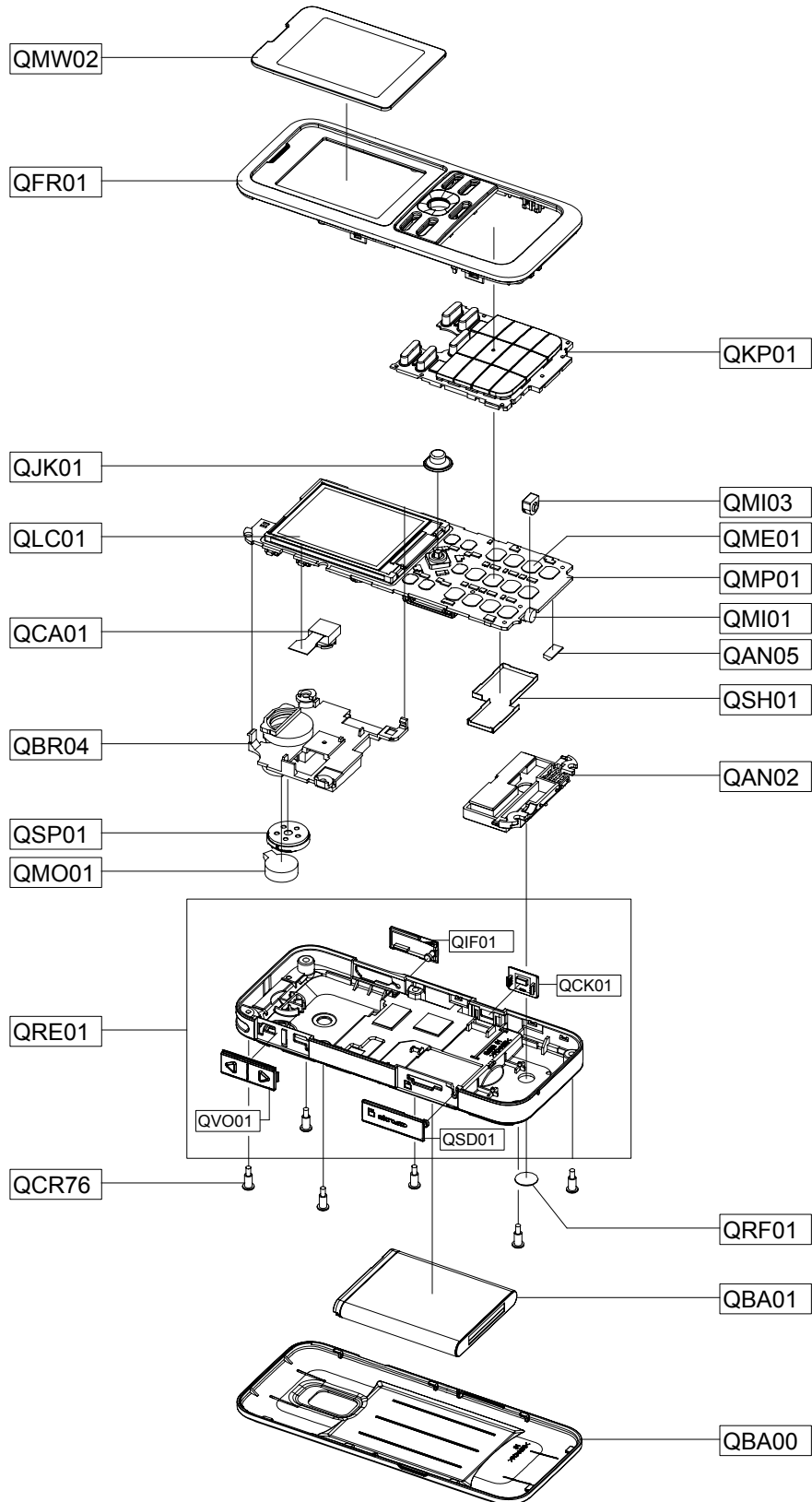

5-2. Cellular phone Parts List

Design LOC		Description	SEC CODE
QAN02		INTENNA-SGHJ210	GH42-01379A
QAN05		ASSY MEC-INTENNA CONTACT	GH75-08168A
QBA00		ASSY CASE-BATTERY	GH98-07028A
QBA01		INNER BATTERY PACK-880MAH , BL	GH43-02772A
QBR04		ASSY BRACKET-SPEAKER	GH98-06810A
QCA01		CAMERA MODULE-SGHJ210	GH59-05040A
QCR76		SCREW-SPECIAL	6009-001525
QFR01		ASSY CASE-FRONT	GH98-06289A
QJK01		PMO KEY-JOY STIC	GH72-42275A
QKP01		ASSY KEYPAD-(SER/BLK)	GH98-06829A
QLC01		LCD-SGHJ200	GH07-01146A
QME01		KEY FPCB-M/DOME SHEET 17KEY	GH59-05041A
QMI01		MICROPHONE-ASSY-SGHJ210	GH30-00451A
QMI03		RMO RUBBER-MIC	GH73-10752A
QMO01		MOTOR DC-SPHV5100	GH31-00122A
QMP01		PBA MAIN-SGHJ210	GH92-04158A
QMW02		PCT WINDOW-MAIN	GH72-44338A
QRF01		TAPE-RF SHEET	GH74-35297A
QSH01		ASSY COVER-SHIELD CAN	GH98-07087A
QSP01		MICRO SPEAKER	3001-002221
QRE01		ASSY CASE-REAR	GH98-06290A
	QCK01	PMO KEY-CAMERA	GH72-44801A
	QIF01	PMO COVER-IF V2	GH72-43256A
	QSD01	PMO COVER-SD V2	GH72-43257A
	QVO01	PMO KEY-VOLUME	GH72-42305A

	Description	SEC CODE
	SCREW-TAPPING	6002-001409
	SCREW-TAPPING	6002-001409
	BAG PE	6902-000634
	CBF INTERFACE-DLC APCBS10BBE(S)	GH39-00922A
	ADAPTOR-ATADS10EBE,BLK,EU	GH44-01702A
	S/W CD-SGHJ210 PC LINK CD	GH46-00534A
	EARPHONE-AAEP405QBE,S20P,EU	GH59-05296A
	LABEL(P)-UNIT SEAL	GH68-00518B
	MANUAL-SFC	GH68-04336A
	LABEL(R)-WATER SOAK	GH68-09361A
	MANUAL USERS-EU RUSSIAN	GH68-16587A
	LABEL(R)-MAIN(SER)	GH68-16962A
	CUSHION-CASE(EU)	GH69-05857A
	BOX-UNIT(SER)	GH69-06255A
	VINYL-BOHO FRONT	GH74-34505A
	TAPE-CAMERA INSU	GH74-34508A
	TAPE-PCB1	GH74-34509A
	TAPE-SIM	GH74-35114A
	SPONGE-NAVI	GH74-35179A
	VINYL-BOHO WINDOW	GH74-36154A
	SPONGE	GH74-36725A
	CBF SIGNAL-SPHA560 RF CABLE	GH39-00397A
0.4M	CBF INTERFACE-SGHT409 TEST CAB	GH39-00834A
1.5M	CBF INTERFACE-SGHT409 TEST CAB	GH39-00836A
	INSTALL-TEST JIG BOX	GH80-03306A

6. Main Electrical Parts List

SEC Code	Design LOC	Description	STATUS
0406-001203	ZD500	DIODE-TVS	SA
0406-001223	U702	DIODE-TVS	SA
0406-001223	ZD400	DIODE-TVS	SA
0406-001267	ZD507	DIODE-TVS	SA
0406-001267	ZD508	DIODE-TVS	SA
0406-001279	ZD503	DIODE-TVS	SA
0406-001279	ZD505	DIODE-TVS	SA
0406-001279	ZD700	DIODE-TVS	SA
0406-001279	ZD701	DIODE-TVS	SA
0406-001279	ZD702	DIODE-TVS	SA
0406-001279	ZD703	DIODE-TVS	SA
0406-001279	ZD704	DIODE-TVS	SA
0406-001279	ZD705	DIODE-TVS	SA
0406-001279	ZD706	DIODE-TVS	SA
0406-001279	ZD707	DIODE-TVS	SA
0406-001279	ZD708	DIODE-TVS	SA
0406-001279	ZD709	DIODE-TVS	SA
0406-001279	ZD710	DIODE-TVS	SA
0406-001279	ZD719	DIODE-TVS	SA
0406-001279	ZD720	DIODE-TVS	SA
0406-001279	ZD721	DIODE-TVS	SA
0406-001279	ZD722	DIODE-TVS	SA
0406-001279	ZD723	DIODE-TVS	SA
0406-001279	ZD724	DIODE-TVS	SA
0406-001286	ZD502	DIODE-TVS	SA
0406-001286	ZD504	DIODE-TVS	SA
0406-001288	ZD501	DIODE-TVS	SA
0406-001288	ZD506	DIODE-TVS	SA
0406-001288	ZD509	DIODE-TVS	SA
0406-001288	ZD711	DIODE-TVS	SA
0406-001288	ZD712	DIODE-TVS	SA
0406-001288	ZD713	DIODE-TVS	SA
0406-001288	ZD714	DIODE-TVS	SA
0407-001002	D700	DIODE-ARRAY	SA
0505-002207	TR400	FET-SILICON	SA
0601-002265	LED700	LED	SA
0601-002265	LED701	LED	SA
0601-002265	LED702	LED	SA
0601-002265	LED703	LED	SA
0601-002265	LED704	LED	SA
0601-002265	LED705	LED	SA
0601-002265	LED706	LED	SA
0601-002265	LED707	LED	SA
0601-002265	LED708	LED	SA
0601-002265	LED709	LED	SA
0601-002265	LED710	LED	SA
0601-002265	LED711	LED	SA
0601-002265	LED712	LED	SA
0601-002265	LED713	LED	SA
0601-002265	LED714	LED	SA
0601-002265	LED715	LED	SA
0801-003012	U100	IC-CMOS LOGIC	SA
0801-003022	U300	IC-CMOS LOGIC	SA
0801-003130	U503	IC-CMOS LOGIC	SA

Main Electrical Parts List

0902-002142	U301	IC-MICROPROCESSOR	SA
1001-001401	U501	IC-ANALOG SWITCH	SA
1001-001410	U601	IC-ANALOG SWITCH	SA
1001-001410	U605	IC-ANALOG SWITCH	SA
1108-000102	UME300	IC-MCP	SA
1201-002492	U600	IC-AUDIO AMP	SA
1201-002576	U102	IC-POWER AMP	SA
1203-003708	U604	IC-DC/DC CONVERTER	SA
1203-003737	U400	IC-POSI.FIXED REG.	SA
1203-003737	U401	IC-POSI.FIXED REG.	SA
1203-003737	U402	IC-POSI.FIXED REG.	SA
1203-003737	U405	IC-POSI.FIXED REG.	SA
1203-003737	U602	IC-POSI.FIXED REG.	SA
1203-003787	U406	IC-POSI.FIXED REG.	SA
1203-004291	U403	IC-MULTI REG.	SA
1203-004382	U404	IC-POWER SUPERVISOR	SA
1205-003082	UCP200	IC-COMM. CONTROLLER	SA
1205-003214	U603	IC-CODEC	SA
1205-003216	U101	IC-TRANSCEIVER	SA
1205-003283	U104	IC-TRANSCEIVER	SA
1404-001221	VR200	THERMISTOR-NTC	SA
2007-000138	R526	R-CHIP	SA
2007-000138	R603	R-CHIP	SA
2007-000138	R608	R-CHIP	SA
2007-000140	R108	R-CHIP	SA
2007-000140	R211	R-CHIP	SA
2007-000140	R320	R-CHIP	SA
2007-000141	R318	R-CHIP	SA
2007-000141	R319	R-CHIP	SA
2007-000141	R407	R-CHIP	SA
2007-000143	R110	R-CHIP	SA
2007-000143	R312	R-CHIP	SA
2007-000143	R321	R-CHIP	SA
2007-000148	R200	R-CHIP	SA
2007-000148	R201	R-CHIP	SA
2007-000148	R202	R-CHIP	SA
2007-000148	R203	R-CHIP	SA
2007-000148	R213	R-CHIP	SA
2007-000148	R221	R-CHIP	SA
2007-000148	R305	R-CHIP	SA
2007-000148	R307	R-CHIP	SA
2007-000148	R311	R-CHIP	SA
2007-000148	R322	R-CHIP	SA
2007-000148	R501	R-CHIP	SA
2007-000148	R502	R-CHIP	SA
2007-000148	R509	R-CHIP	SA
2007-000148	R510	R-CHIP	SA
2007-000148	R516	R-CHIP	SA
2007-000148	R610	R-CHIP	SA
2007-000157	R300	R-CHIP	SA
2007-000157	R301	R-CHIP	SA
2007-000157	R302	R-CHIP	SA
2007-000157	R304	R-CHIP	SA
2007-000157	R306	R-CHIP	SA
2007-000157	R308	R-CHIP	SA
2007-000157	R314	R-CHIP	SA

2007-000157	R507	R-CHIP	SA
2007-000157	R605	R-CHIP	SA
2007-000157	R606	R-CHIP	SA
2007-000159	R517	R-CHIP	SA
2007-000159	R518	R-CHIP	SA
2007-000159	R519	R-CHIP	SA
2007-000159	R520	R-CHIP	SA
2007-000159	R521	R-CHIP	SA
2007-000159	R522	R-CHIP	SA
2007-000162	R103	R-CHIP	SA
2007-000162	R212	R-CHIP	SA
2007-000162	R303	R-CHIP	SA
2007-000162	R315	R-CHIP	SA
2007-000162	R408	R-CHIP	SA
2007-000162	R410	R-CHIP	SA
2007-000162	R411	R-CHIP	SA
2007-000162	R414	R-CHIP	SA
2007-000166	R523	R-CHIP	SA
2007-000170	R503	R-CHIP	SA
2007-000170	R504	R-CHIP	SA
2007-000171	R104	R-CHIP	SA
2007-000171	R105	R-CHIP	SA
2007-000171	R106	R-CHIP	SA
2007-000171	R206	R-CHIP	SA
2007-000171	R207	R-CHIP	SA
2007-000171	R208	R-CHIP	SA
2007-000171	R313	R-CHIP	SA
2007-000171	R409	R-CHIP	SA
2007-000171	R413	R-CHIP	SA
2007-000171	R417	R-CHIP	SA
2007-000172	R602	R-CHIP	SA
2007-000172	R604	R-CHIP	SA
2007-000758	R217	R-CHIP	SA
2007-000758	R218	R-CHIP	SA
2007-000758	R412	R-CHIP	SA
2007-001292	R600	R-CHIP	SA
2007-001292	R601	R-CHIP	SA
2007-001298	R700	R-CHIP	SA
2007-001298	R701	R-CHIP	SA
2007-001298	R702	R-CHIP	SA
2007-001298	R703	R-CHIP	SA
2007-001298	R704	R-CHIP	SA
2007-001298	R705	R-CHIP	SA
2007-001298	R706	R-CHIP	SA
2007-001298	R707	R-CHIP	SA
2007-001298	R708	R-CHIP	SA
2007-001298	R709	R-CHIP	SA
2007-001298	R710	R-CHIP	SA
2007-001298	R711	R-CHIP	SA
2007-001298	R712	R-CHIP	SA
2007-001298	R713	R-CHIP	SA
2007-001298	R714	R-CHIP	SA
2007-001298	R715	R-CHIP	SA
2007-001319	R215	R-CHIP	SA
2007-001319	R216	R-CHIP	SA
2007-001333	R401	R-CHIP	SA

Main Electrical Parts List

2007-001333	R402	R-CHIP	SA
2007-001333	R525	R-CHIP	SA
2007-001333	R607	R-CHIP	SA
2007-001339	R508	R-CHIP	SA
2007-002796	R220	R-CHIP	SA
2007-002796	R506	R-CHIP	SA
2007-002796	R612	R-CHIP	SA
2007-007001	R209	R-CHIP	SA
2007-007001	R310	R-CHIP	SA
2007-007107	R204	R-CHIP	SA
2007-007107	R316	R-CHIP	SA
2007-007107	R317	R-CHIP	SA
2007-007142	R109	R-CHIP	SA
2007-007142	R511	R-CHIP	SA
2007-007311	R406	R-CHIP	SA
2007-007312	R513	R-CHIP	SA
2007-007334	R512	R-CHIP	SA
2007-007489	R101	R-CHIP	SA
2007-007528	R500	R-CHIP	SA
2007-007528	R505	R-CHIP	SA
2007-007528	R609	R-CHIP	SA
2007-007528	R611	R-CHIP	SA
2007-007573	R210	R-CHIP	SA
2007-007573	R400	R-CHIP	SA
2007-008117	R309	R-CHIP	SA
2007-008354	R403	R-CHIP	SA
2203-000138	C128	C-CER,CHIP	SA
2203-000138	C129	C-CER,CHIP	SA
2203-000138	C130	C-CER,CHIP	SA
2203-000233	C132	C-CER,CHIP	SA
2203-000233	C136	C-CER,CHIP	SA
2203-000233	C138	C-CER,CHIP	SA
2203-000233	C417	C-CER,CHIP	SA
2203-000254	C140	C-CER,CHIP	SA
2203-000254	C211	C-CER,CHIP	SA
2203-000254	C305	C-CER,CHIP	SA
2203-000254	C308	C-CER,CHIP	SA
2203-000254	C311	C-CER,CHIP	SA
2203-000254	C313	C-CER,CHIP	SA
2203-000254	C515	C-CER,CHIP	SA
2203-000254	C519	C-CER,CHIP	SA
2203-000278	C106	C-CER,CHIP	SA
2203-000278	C111	C-CER,CHIP	SA
2203-000278	C121	C-CER,CHIP	SA
2203-000278	C131	C-CER,CHIP	SA
2203-000311	C518	C-CER,CHIP	SA
2203-000330	C126	C-CER,CHIP	SA
2203-000330	C507	C-CER,CHIP	SA
2203-000386	C634	C-CER,CHIP	SA
2203-000425	C419	C-CER,CHIP	SA
2203-000425	C422	C-CER,CHIP	SA
2203-000438	C100	C-CER,CHIP	SA
2203-000438	C107	C-CER,CHIP	SA
2203-000438	C139	C-CER,CHIP	SA
2203-000628	C217	C-CER,CHIP	SA
2203-000628	C218	C-CER,CHIP	SA

2203-000628	C316	C-CER,CHIP	SA
2203-000628	C317	C-CER,CHIP	SA
2203-000628	C320	C-CER,CHIP	SA
2203-000628	C321	C-CER,CHIP	SA
2203-000679	C141	C-CER,CHIP	SA
2203-000679	C220	C-CER,CHIP	SA
2203-000679	C221	C-CER,CHIP	SA
2203-000812	C110	C-CER,CHIP	SA
2203-000812	C117	C-CER,CHIP	SA
2203-000812	C118	C-CER,CHIP	SA
2203-000812	C133	C-CER,CHIP	SA
2203-000812	C201	C-CER,CHIP	SA
2203-000812	C204	C-CER,CHIP	SA
2203-000812	C213	C-CER,CHIP	SA
2203-000812	C520	C-CER,CHIP	SA
2203-000812	C521	C-CER,CHIP	SA
2203-000812	C522	C-CER,CHIP	SA
2203-000812	C523	C-CER,CHIP	SA
2203-000812	C524	C-CER,CHIP	SA
2203-000812	C525	C-CER,CHIP	SA
2203-000812	C526	C-CER,CHIP	SA
2203-000812	C527	C-CER,CHIP	SA
2203-000812	C531	C-CER,CHIP	SA
2203-000812	C532	C-CER,CHIP	SA
2203-000812	C533	C-CER,CHIP	SA
2203-000812	C536	C-CER,CHIP	SA
2203-000812	C537	C-CER,CHIP	SA
2203-000812	C538	C-CER,CHIP	SA
2203-000812	C539	C-CER,CHIP	SA
2203-000812	C540	C-CER,CHIP	SA
2203-000812	C541	C-CER,CHIP	SA
2203-000812	C542	C-CER,CHIP	SA
2203-000812	C543	C-CER,CHIP	SA
2203-000854	C633	C-CER,CHIP	SA
2203-000854	C636	C-CER,CHIP	SA
2203-000870	C105	C-CER,CHIP	SA
2203-000995	C102	C-CER,CHIP	SA
2203-000995	C103	C-CER,CHIP	SA
2203-001153	C512	C-CER,CHIP	SA
2203-001153	C513	C-CER,CHIP	SA
2203-001153	C514	C-CER,CHIP	SA
2203-001239	C613	C-CER,CHIP	SA
2203-001239	C614	C-CER,CHIP	SA
2203-001239	C615	C-CER,CHIP	SA
2203-001239	C616	C-CER,CHIP	SA
2203-001239	C700	C-CER,CHIP	SA
2203-001239	C701	C-CER,CHIP	SA
2203-001259	C503	C-CER,CHIP	SA
2203-001437	C501	C-CER,CHIP	SA
2203-001437	C508	C-CER,CHIP	SA
2203-003054	C637	C-CER,CHIP	SA
2203-005050	C112	C-CER,CHIP	SA
2203-005050	C113	C-CER,CHIP	SA
2203-005050	C122	C-CER,CHIP	SA
2203-005138	C318	C-CER,CHIP	SA
2203-005138	C319	C-CER,CHIP	SA

Main Electrical Parts List

2203-005288	C115	C-CER,CHIP	SA
2203-005288	C116	C-CER,CHIP	SA
2203-005288	C119	C-CER,CHIP	SA
2203-005288	C120	C-CER,CHIP	SA
2203-005395	C502	C-CER,CHIP	SA
2203-005395	C509	C-CER,CHIP	SA
2203-005446	C127	C-CER,CHIP	SA
2203-005480	C605	C-CER,CHIP	SA
2203-005480	C606	C-CER,CHIP	SA
2203-005480	C622	C-CER,CHIP	SA
2203-005480	C627	C-CER,CHIP	SA
2203-005482	C104	C-CER,CHIP	SA
2203-005482	C135	C-CER,CHIP	SA
2203-005482	C200	C-CER,CHIP	SA
2203-005482	C202	C-CER,CHIP	SA
2203-005482	C203	C-CER,CHIP	SA
2203-005482	C205	C-CER,CHIP	SA
2203-005482	C206	C-CER,CHIP	SA
2203-005482	C207	C-CER,CHIP	SA
2203-005482	C208	C-CER,CHIP	SA
2203-005482	C212	C-CER,CHIP	SA
2203-005482	C214	C-CER,CHIP	SA
2203-005482	C215	C-CER,CHIP	SA
2203-005482	C216	C-CER,CHIP	SA
2203-005482	C300	C-CER,CHIP	SA
2203-005482	C301	C-CER,CHIP	SA
2203-005482	C302	C-CER,CHIP	SA
2203-005482	C303	C-CER,CHIP	SA
2203-005482	C304	C-CER,CHIP	SA
2203-005482	C306	C-CER,CHIP	SA
2203-005482	C309	C-CER,CHIP	SA
2203-005482	C312	C-CER,CHIP	SA
2203-005482	C314	C-CER,CHIP	SA
2203-005482	C315	C-CER,CHIP	SA
2203-005482	C322	C-CER,CHIP	SA
2203-005482	C434	C-CER,CHIP	SA
2203-005482	C504	C-CER,CHIP	SA
2203-005482	C506	C-CER,CHIP	SA
2203-005482	C511	C-CER,CHIP	SA
2203-005482	C516	C-CER,CHIP	SA
2203-005482	C530	C-CER,CHIP	SA
2203-005482	C534	C-CER,CHIP	SA
2203-005482	C602	C-CER,CHIP	SA
2203-005482	C604	C-CER,CHIP	SA
2203-005482	C617	C-CER,CHIP	SA
2203-005482	C632	C-CER,CHIP	SA
2203-005482	C635	C-CER,CHIP	SA
2203-006048	C108	C-CER,CHIP	SA
2203-006048	C603	C-CER,CHIP	SA
2203-006208	C405	C-CER,CHIP	SA
2203-006208	C407	C-CER,CHIP	SA
2203-006208	C409	C-CER,CHIP	SA
2203-006208	C411	C-CER,CHIP	SA
2203-006208	C412	C-CER,CHIP	SA
2203-006208	C529	C-CER,CHIP	SA
2203-006208	C535	C-CER,CHIP	SA

2203-006257	C406	C-CER,CHIP	SA
2203-006257	C408	C-CER,CHIP	SA
2203-006257	C410	C-CER,CHIP	SA
2203-006257	C414	C-CER,CHIP	SA
2203-006257	C416	C-CER,CHIP	SA
2203-006257	C424	C-CER,CHIP	SA
2203-006260	C626	C-CER,CHIP	SA
2203-006260	C629	C-CER,CHIP	SA
2203-006324	C423	C-CER,CHIP	SA
2203-006361	C429	C-CER,CHIP	SA
2203-006399	C428	C-CER,CHIP	SA
2203-006474	C430	C-CER,CHIP	SA
2203-006562	C101	C-CER,CHIP	SA
2203-006562	C109	C-CER,CHIP	SA
2203-006562	C114	C-CER,CHIP	SA
2203-006562	C307	C-CER,CHIP	SA
2203-006562	C310	C-CER,CHIP	SA
2203-006562	C400	C-CER,CHIP	SA
2203-006562	C401	C-CER,CHIP	SA
2203-006562	C403	C-CER,CHIP	SA
2203-006562	C404	C-CER,CHIP	SA
2203-006562	C413	C-CER,CHIP	SA
2203-006562	C415	C-CER,CHIP	SA
2203-006562	C421	C-CER,CHIP	SA
2203-006562	C426	C-CER,CHIP	SA
2203-006562	C427	C-CER,CHIP	SA
2203-006562	C431	C-CER,CHIP	SA
2203-006562	C432	C-CER,CHIP	SA
2203-006562	C433	C-CER,CHIP	SA
2203-006562	C435	C-CER,CHIP	SA
2203-006562	C436	C-CER,CHIP	SA
2203-006562	C505	C-CER,CHIP	SA
2203-006562	C528	C-CER,CHIP	SA
2203-006562	C607	C-CER,CHIP	SA
2203-006562	C608	C-CER,CHIP	SA
2203-006562	C610	C-CER,CHIP	SA
2203-006562	C611	C-CER,CHIP	SA
2203-006562	C612	C-CER,CHIP	SA
2203-006562	C618	C-CER,CHIP	SA
2203-006562	C619	C-CER,CHIP	SA
2203-006562	C620	C-CER,CHIP	SA
2203-006562	C621	C-CER,CHIP	SA
2203-006562	C623	C-CER,CHIP	SA
2203-006562	C624	C-CER,CHIP	SA
2203-006562	C625	C-CER,CHIP	SA
2203-006562	C628	C-CER,CHIP	SA
2203-006681	C134	C-CER,CHIP	SA
2203-006681	C137	C-CER,CHIP	SA
2203-006681	C420	C-CER,CHIP	SA
2203-006681	C425	C-CER,CHIP	SA
2203-006838	C209	C-CER,CHIP	SA
2203-006838	C210	C-CER,CHIP	SA
2203-006838	C640	C-CER,CHIP	SA
2203-006838	C641	C-CER,CHIP	SA
2203-006838	C642	C-CER,CHIP	SA
2203-006838	C704	C-CER,CHIP	SA

Main Electrical Parts List

2404-001088	C609	C-TA,CHIP	SA
2404-001339	C219	C-TA,CHIP	SA
2404-001377	C500	C-TA,CHIP	SA
2404-001380	C630	C-TA,CHIP	SA
2404-001381	C402	C-TA,CHIP	SA
2404-001381	C510	C-TA,CHIP	SA
2404-001381	C517	C-TA,CHIP	SA
2404-001381	C544	C-TA,CHIP	SA
2404-001381	C601	C-TA,CHIP	SA
2404-001396	C600	C-TA,CHIP	SA
2404-001496	C124	C-TA,CHIP	SA
2703-002155	L500	INDUCTOR-SMD	SA
2703-002176	L115	INDUCTOR-SMD	SA
2703-002205	L102	INDUCTOR-SMD	SA
2703-002308	L106	INDUCTOR-SMD	SA
2703-002313	L101	INDUCTOR-SMD	SA
2703-002558	L111	INDUCTOR-SMD	SA
2703-002586	L113	INDUCTOR-SMD	SA
2703-002586	L114	INDUCTOR-SMD	SA
2703-002608	L110	INDUCTOR-SMD	SA
2703-002608	L112	INDUCTOR-SMD	SA
2703-002701	L100	INDUCTOR-SMD	SA
2703-003064	L700	INDUCTOR-SMD	SA
2703-003064	L701	INDUCTOR-SMD	SA
2703-003103	L116	INDUCTOR-SMD	SA
2703-003290	L400	INDUCTOR-SMD	SA
2801-004466	OSC300	CRYSTAL-SMD	SA
2801-004466	OSC400	CRYSTAL-SMD	SA
2801-004543	OSC301	CRYSTAL-SMD	SA
2801-004587	OSC100	CRYSTAL-SMD	SA
2901-001316	F500	FILTER-EMI SMD	SA
2901-001408	F501	FILTER-EMI SMD	SA
2909-001279	F100	FILTER-LC	SA
2911-000072	F101	DUPLEXER-FEM	SA
3301-001534	L506	BEAD-SMD	SA
3301-001659	L109	BEAD-SMD	SA
3301-001729	L300	BEAD-SMD	SA
3301-001729	L401	BEAD-SMD	SA
3301-001729	L501	BEAD-SMD	SA
3301-001729	L502	BEAD-SMD	SA
3301-001729	L600	BEAD-SMD	SA
3301-001729	L601	BEAD-SMD	SA
3301-001812	L503	BEAD-SMD	SA
3301-001812	L504	BEAD-SMD	SA
3301-001812	L505	BEAD-SMD	SA
3404-001303	TAC700	SWITCH-TACT	SA
3404-001303	TAC701	SWITCH-TACT	SA
3404-001303	TAC702	SWITCH-TACT	SA
3705-001421	RFS100	CONNECTOR-COAXIAL	SA
3708-002222	CON600	CONNECTOR-FPC/FFC/PIC	SA
3709-001453	T/SIM500	CONNECTOR-CARD EDGE	SA
3710-002499	IFC500	SOCKET-INTERFACE	SA
3711-006084	BATT500	HEADER-BATTERY	SA
4202-001360	ANT100	ANTENNA-CHIP	SA
4302-001181	C418	BATTERY-LI(2ND)	SA
GH59-04723A	SW700	KEY FPCB-SGHJ200, JOG KEY	SA

GH70-02367A	SC100	ICT-ON-BOARD CLIP	SA
GH70-02367A	SC101	ICT-ON-BOARD CLIP	SA
GH70-02367A	SC102	ICT-ON-BOARD CLIP	SA
GH70-02367A	SC103	ICT-ON-BOARD CLIP	SA
GH70-02367A	SC104	ICT-ON-BOARD CLIP	SA
GH70-02367A	SC105	ICT-ON-BOARD CLIP	SA
GH71-06570A	L103	NPR-ANTENNA CONTACT V2	SA
GH71-06570A	L104	NPR-ANTENNA CONTACT V2	SA

Please consult the GSPN website (Samsung Portal) for the most recent version of the product's part list.

7. Block Diagrams

7-1. Base Band Solution Block Diagram

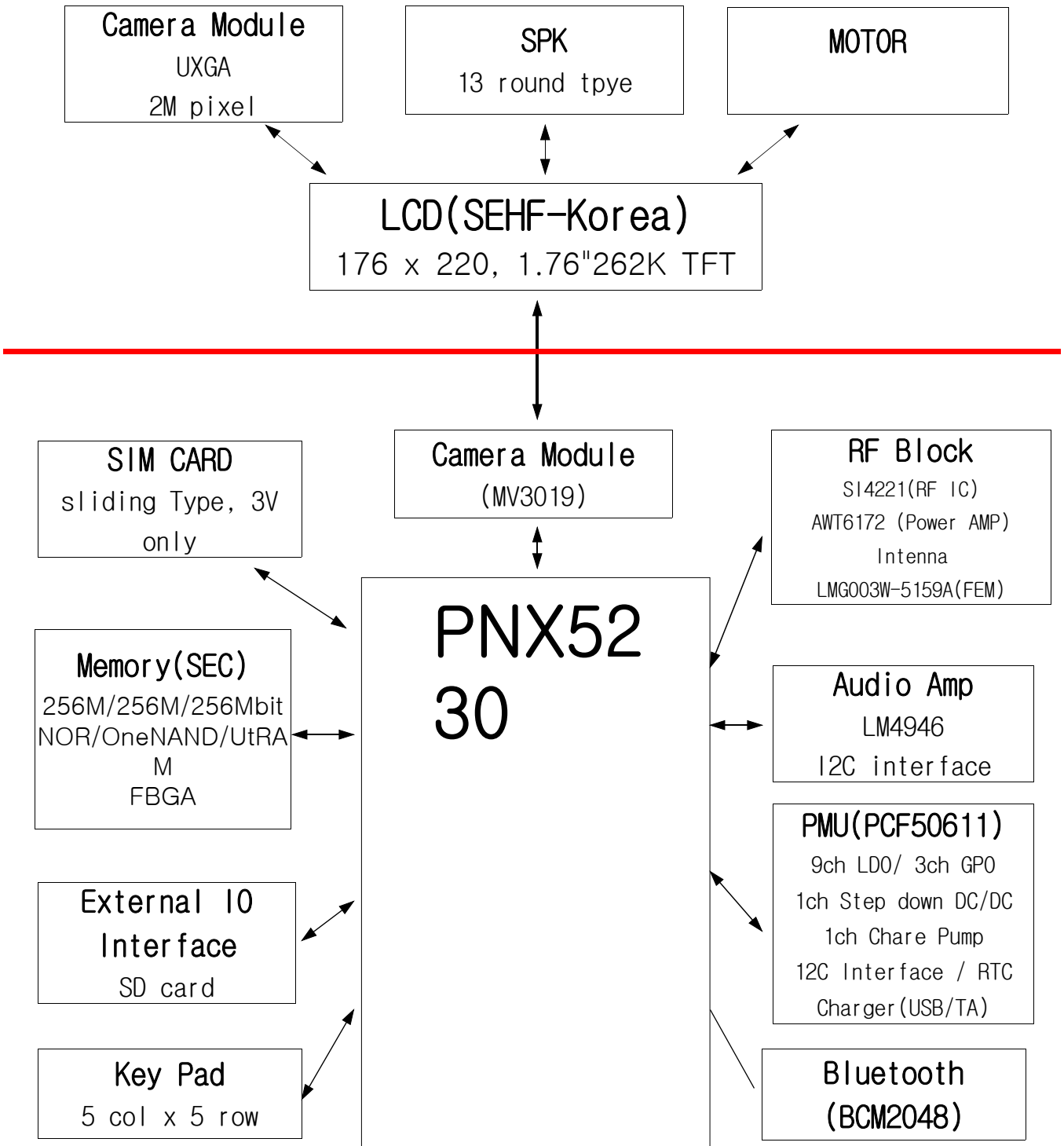

7-2. RF Solution Block Diagram

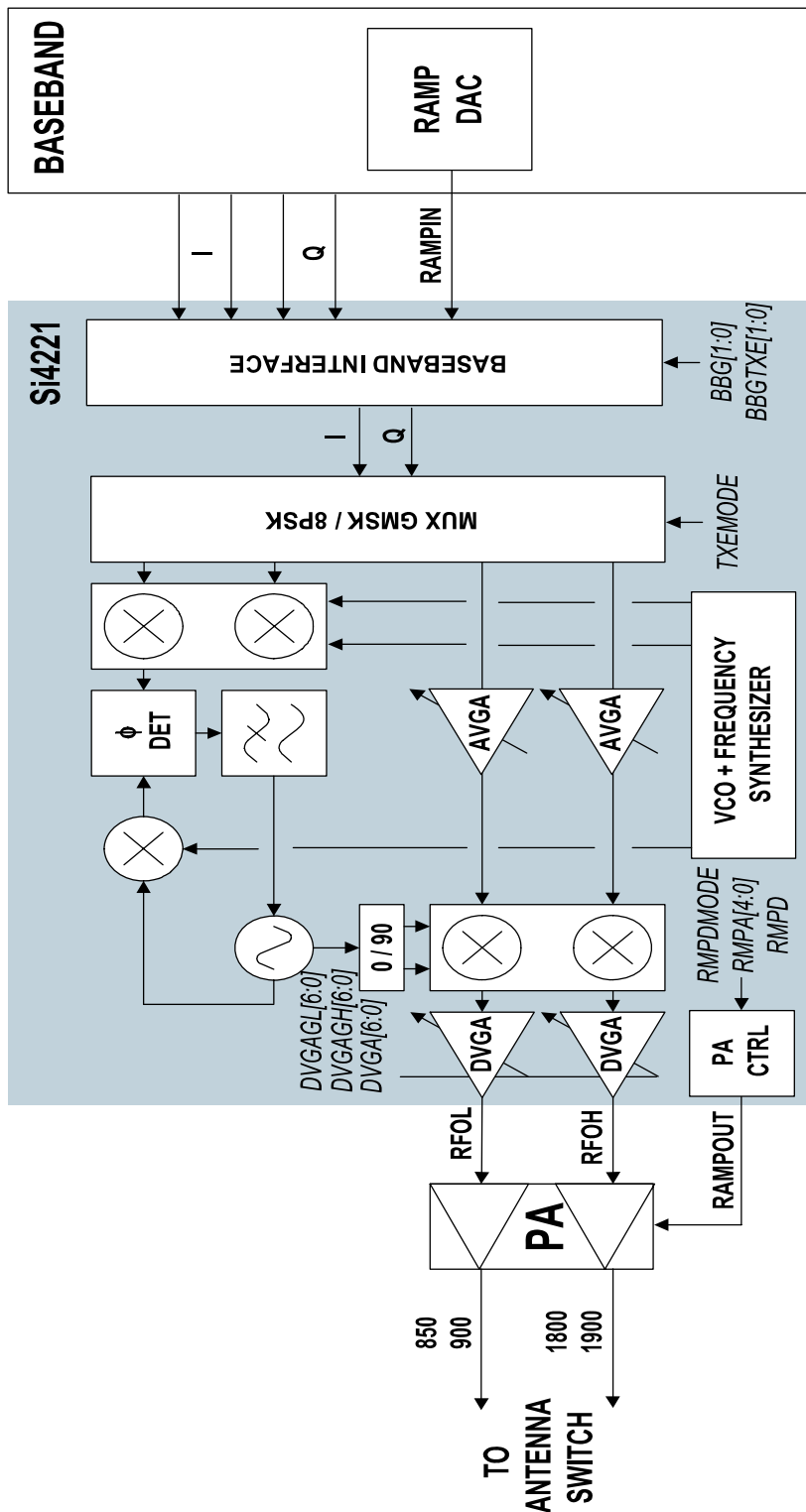

7-3. BT Solution Block Diagram

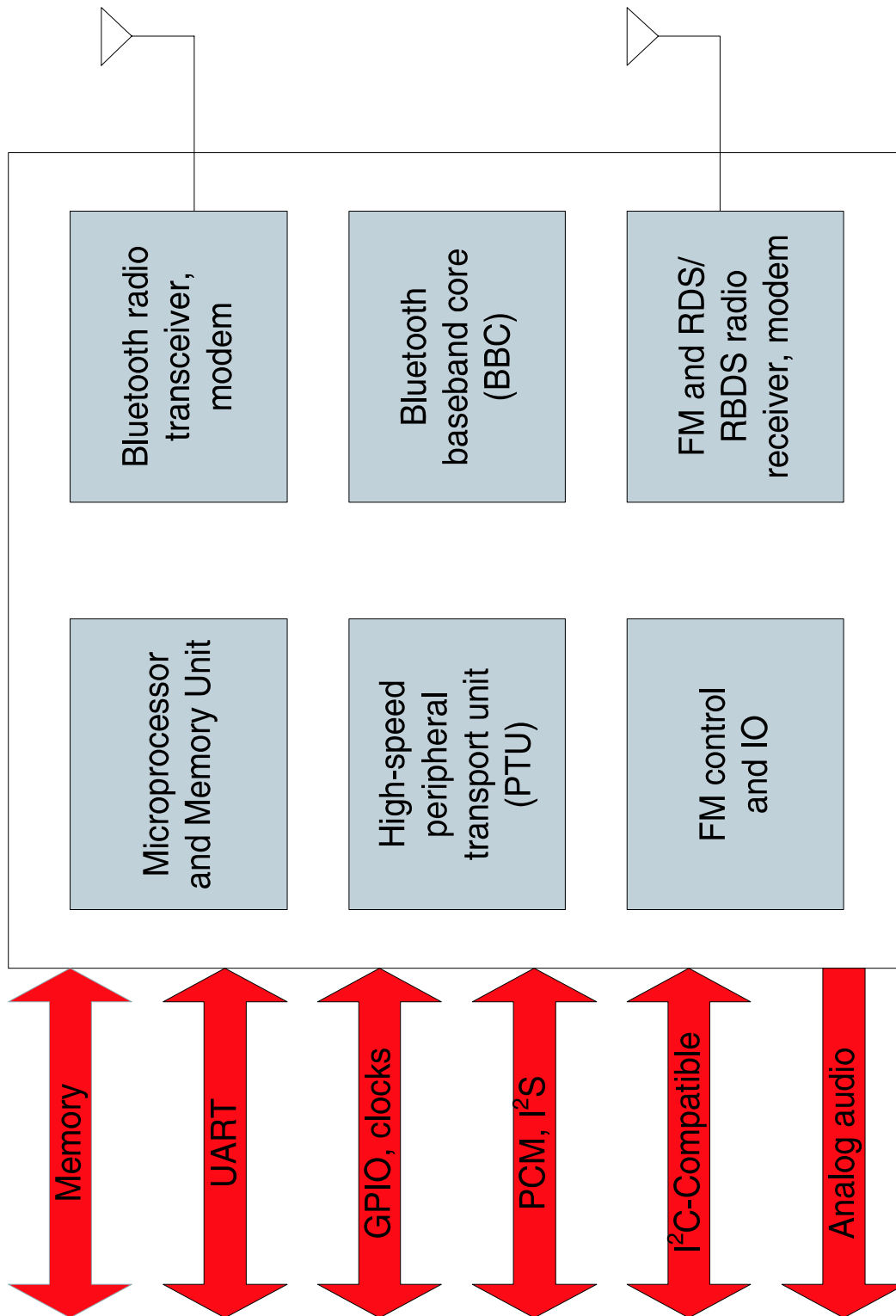

8. PCB Diagrams

- Main top view

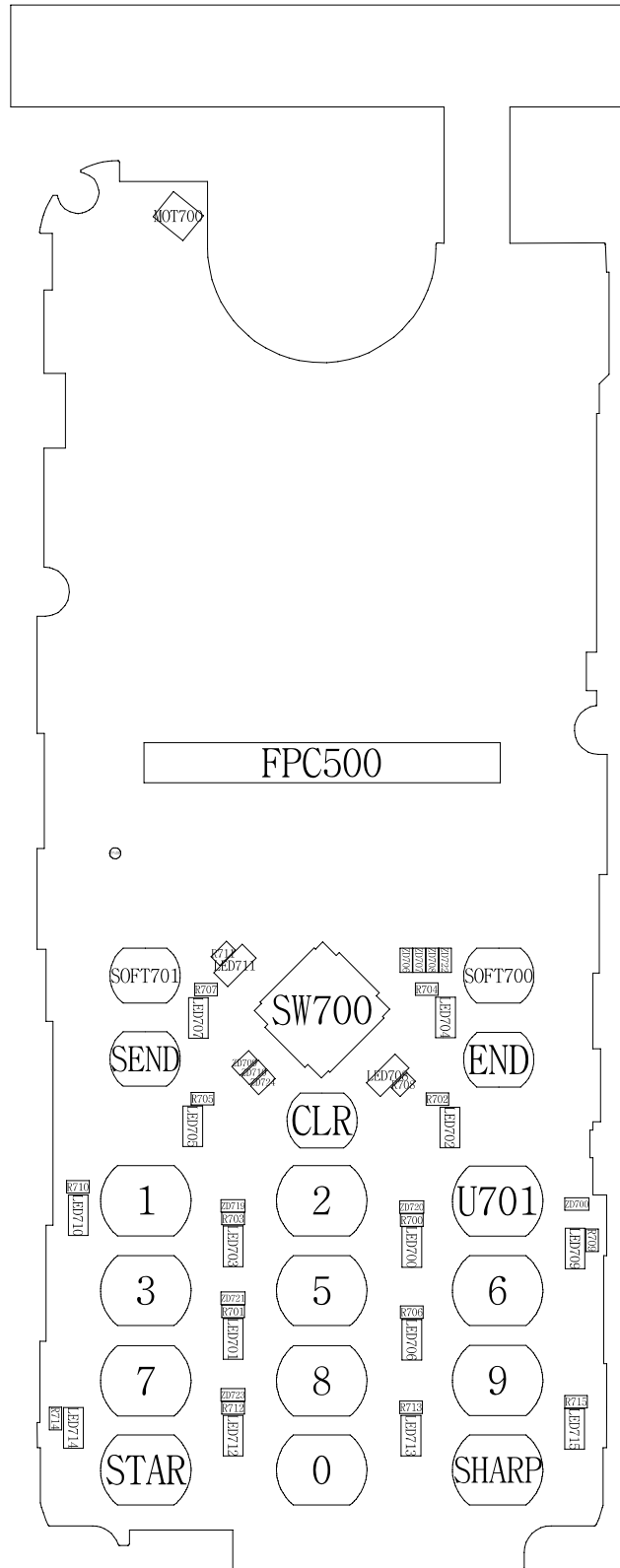

9. Flow Chart of Troubleshooting

9-1. Power On

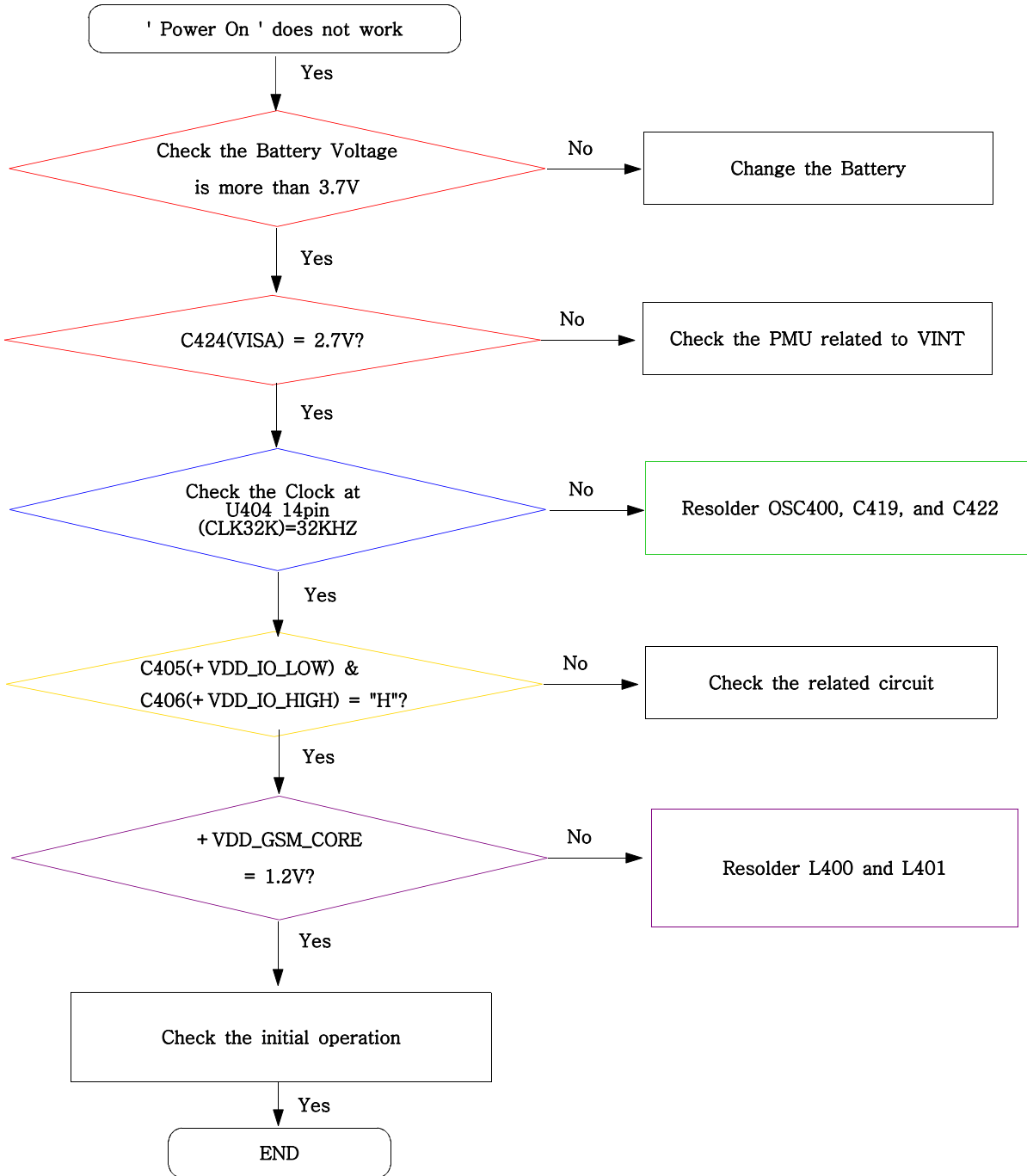

Flow Chart of Troubleshooting

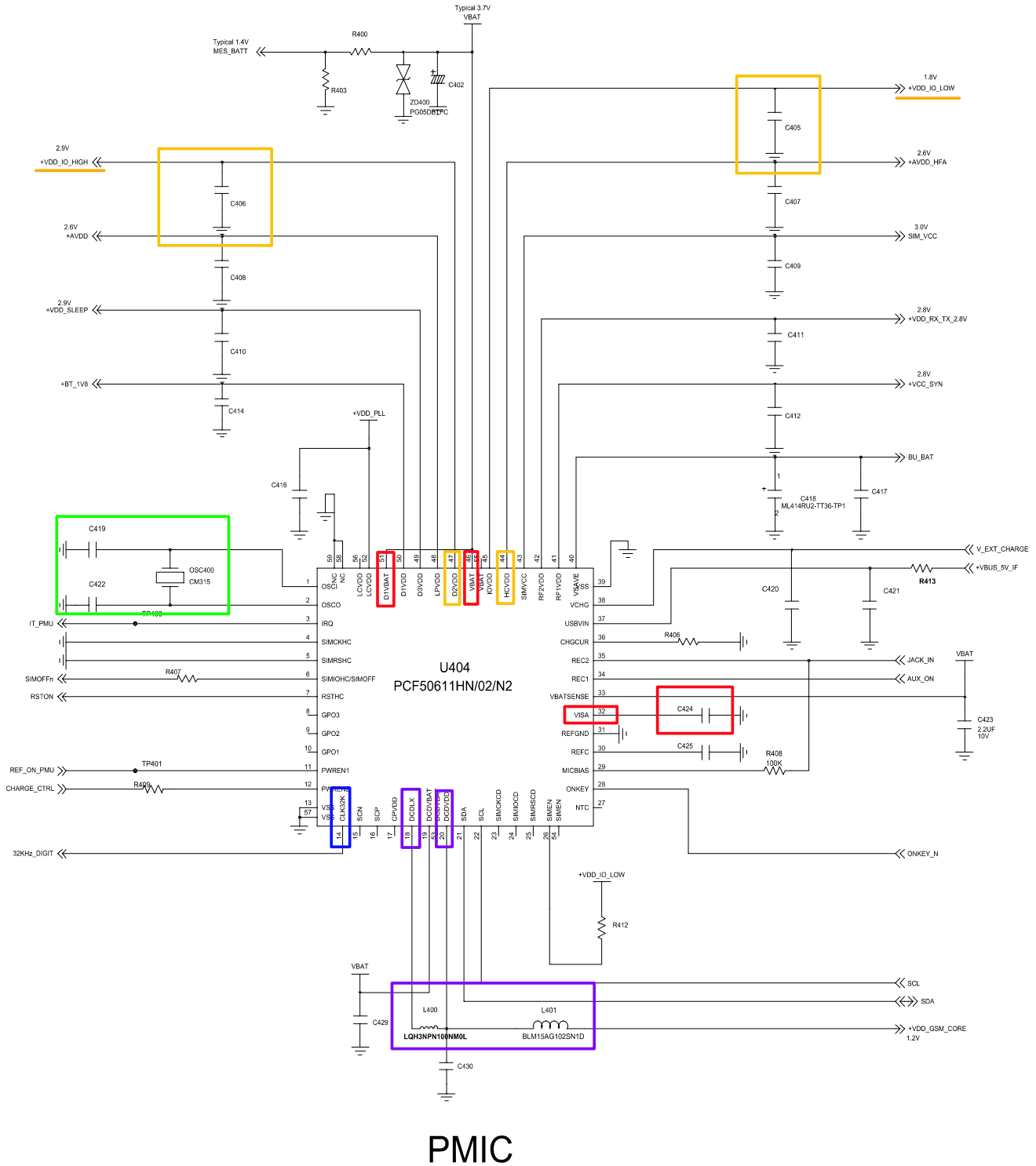

9-2. Initial

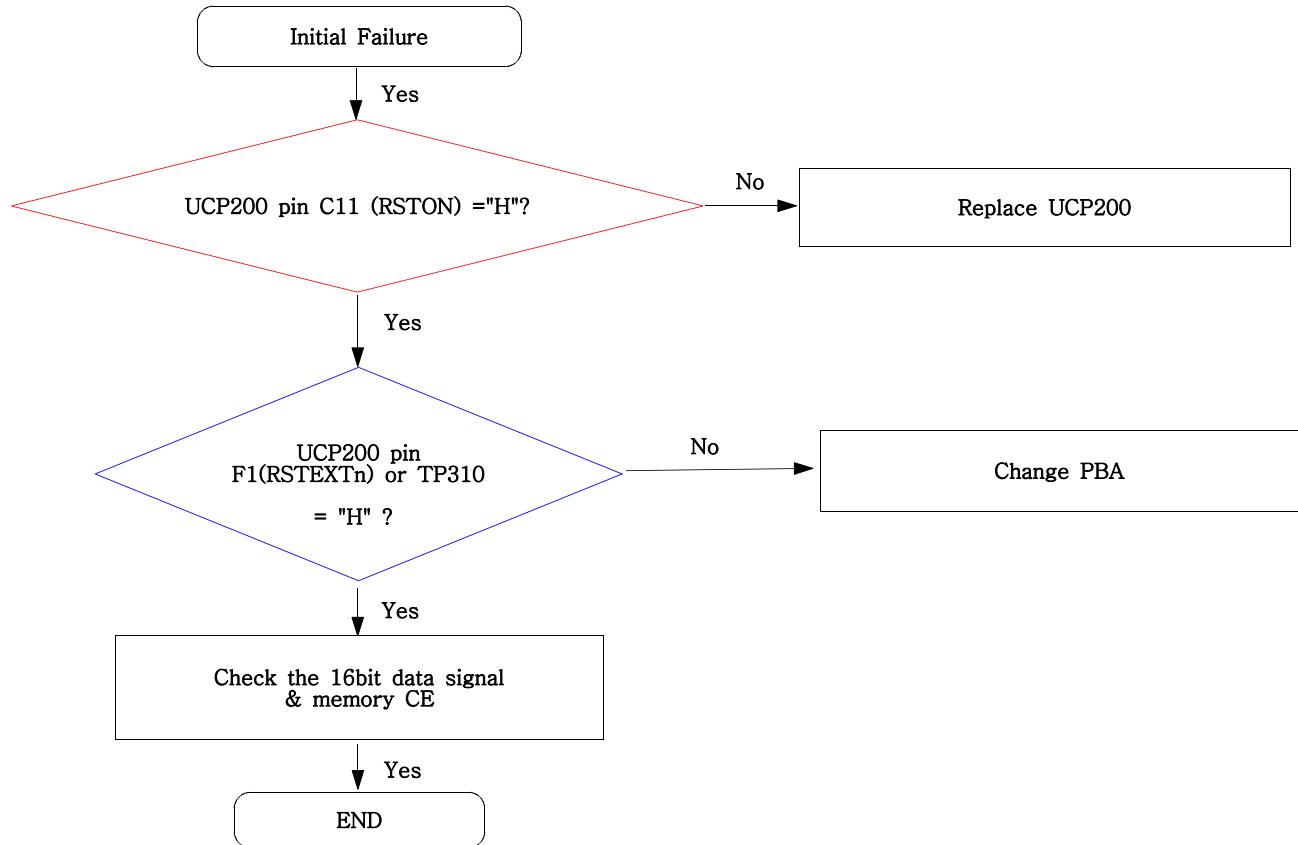

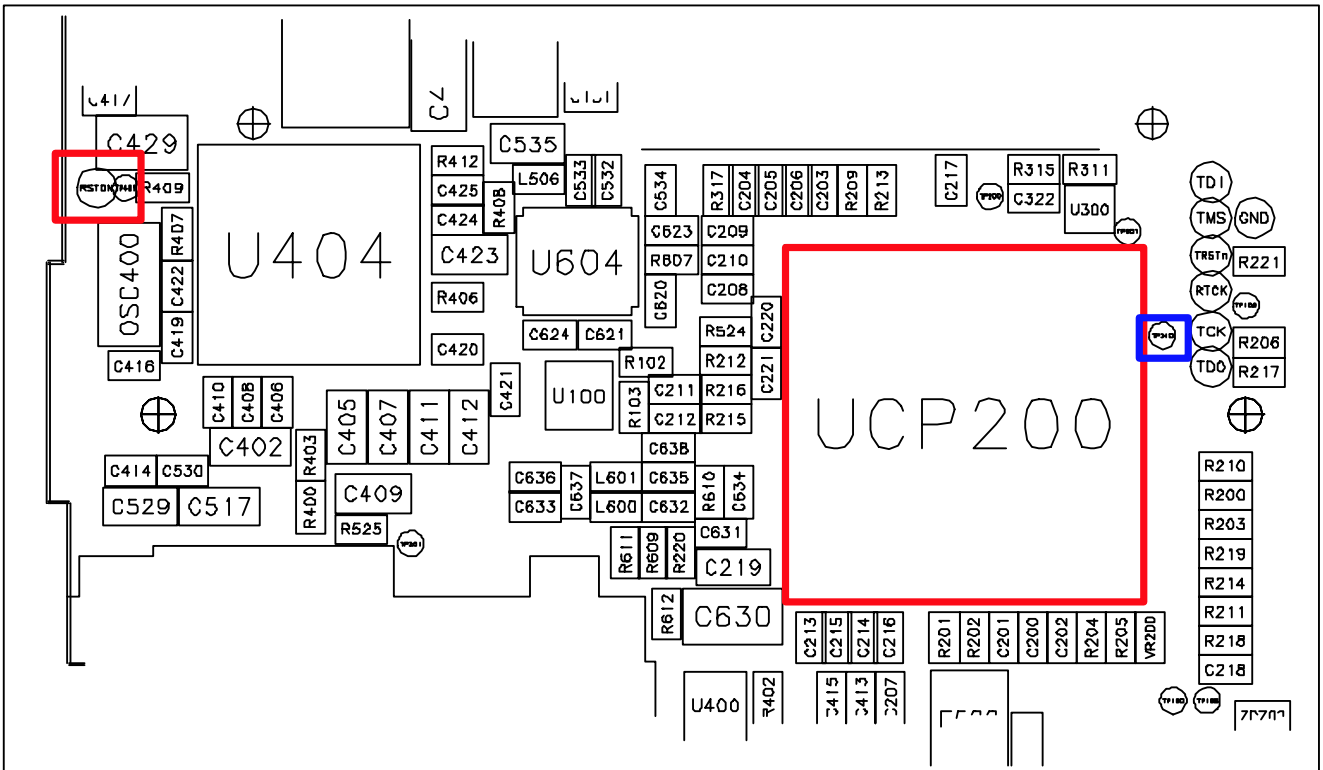
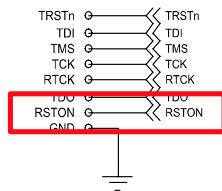
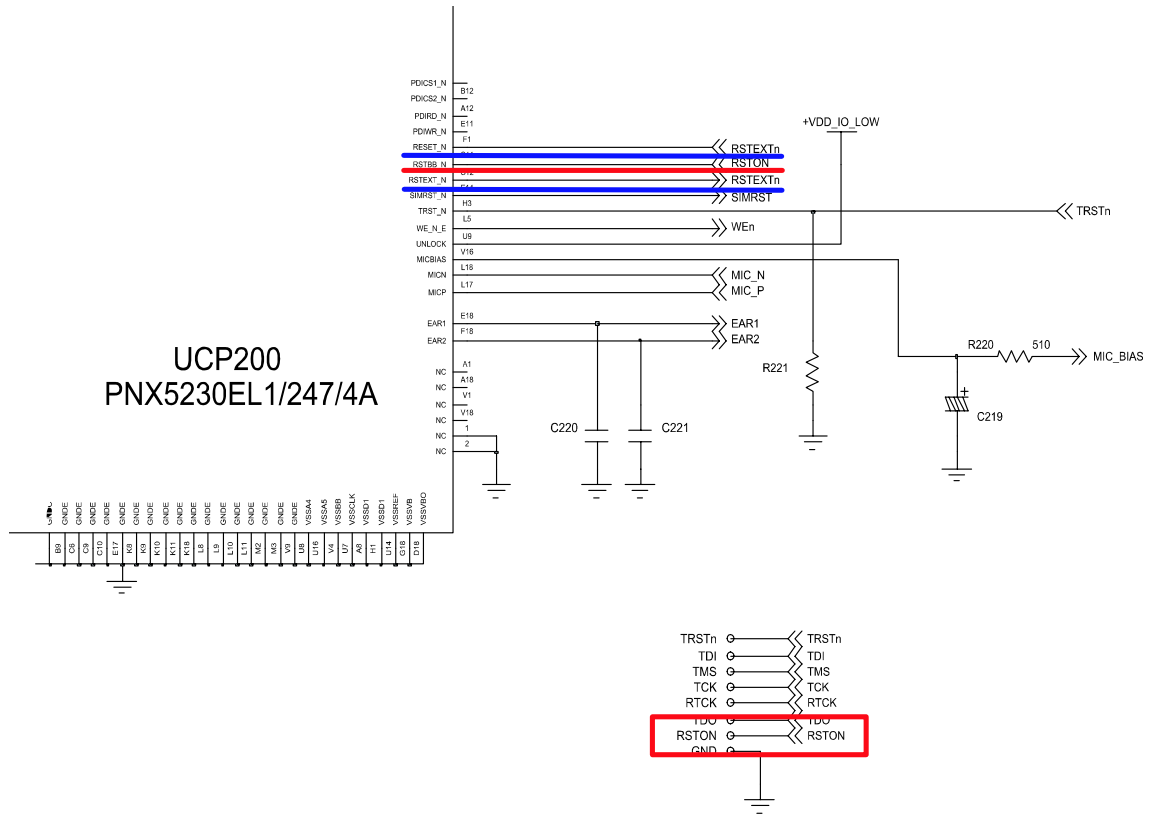

9-3. Charging Part

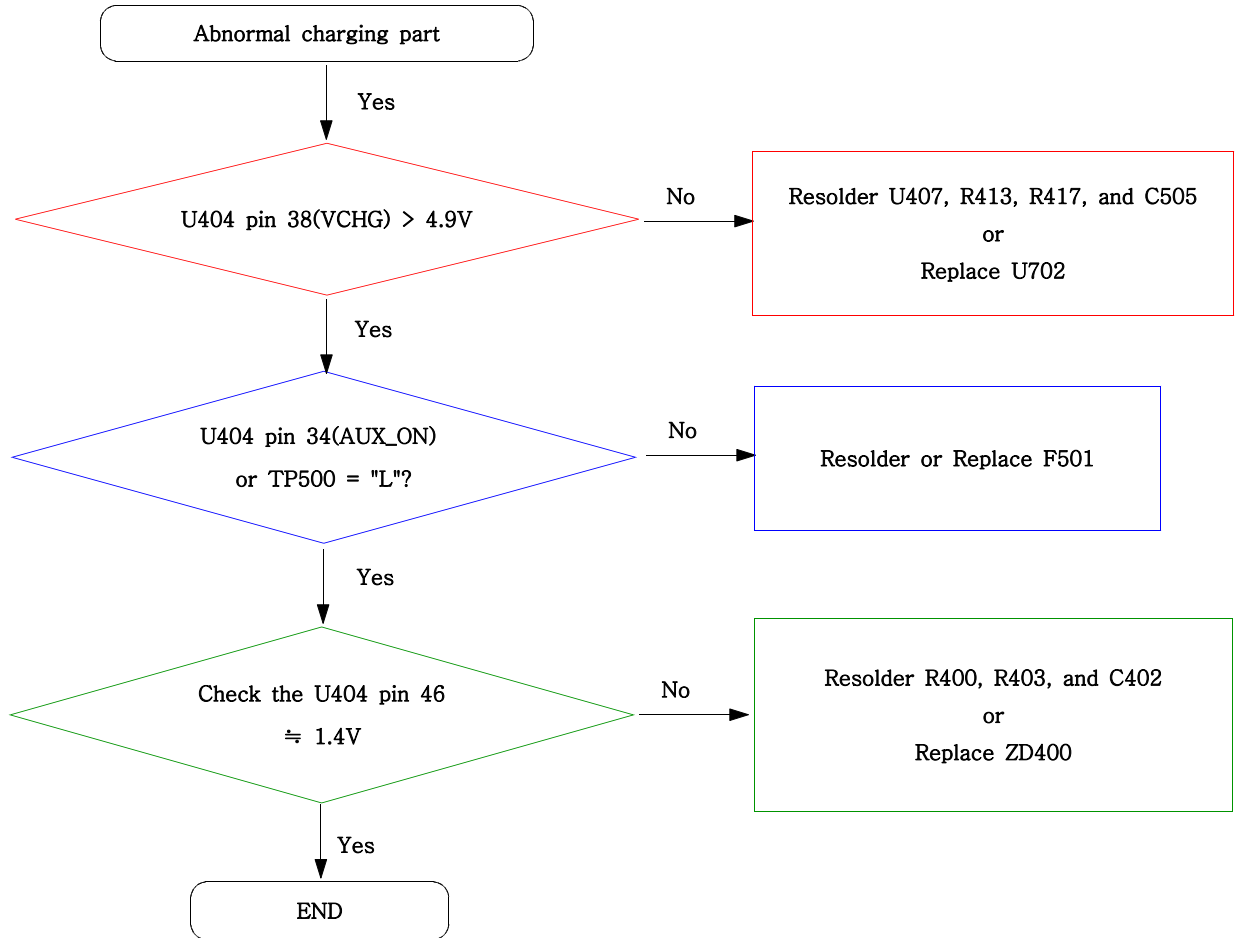

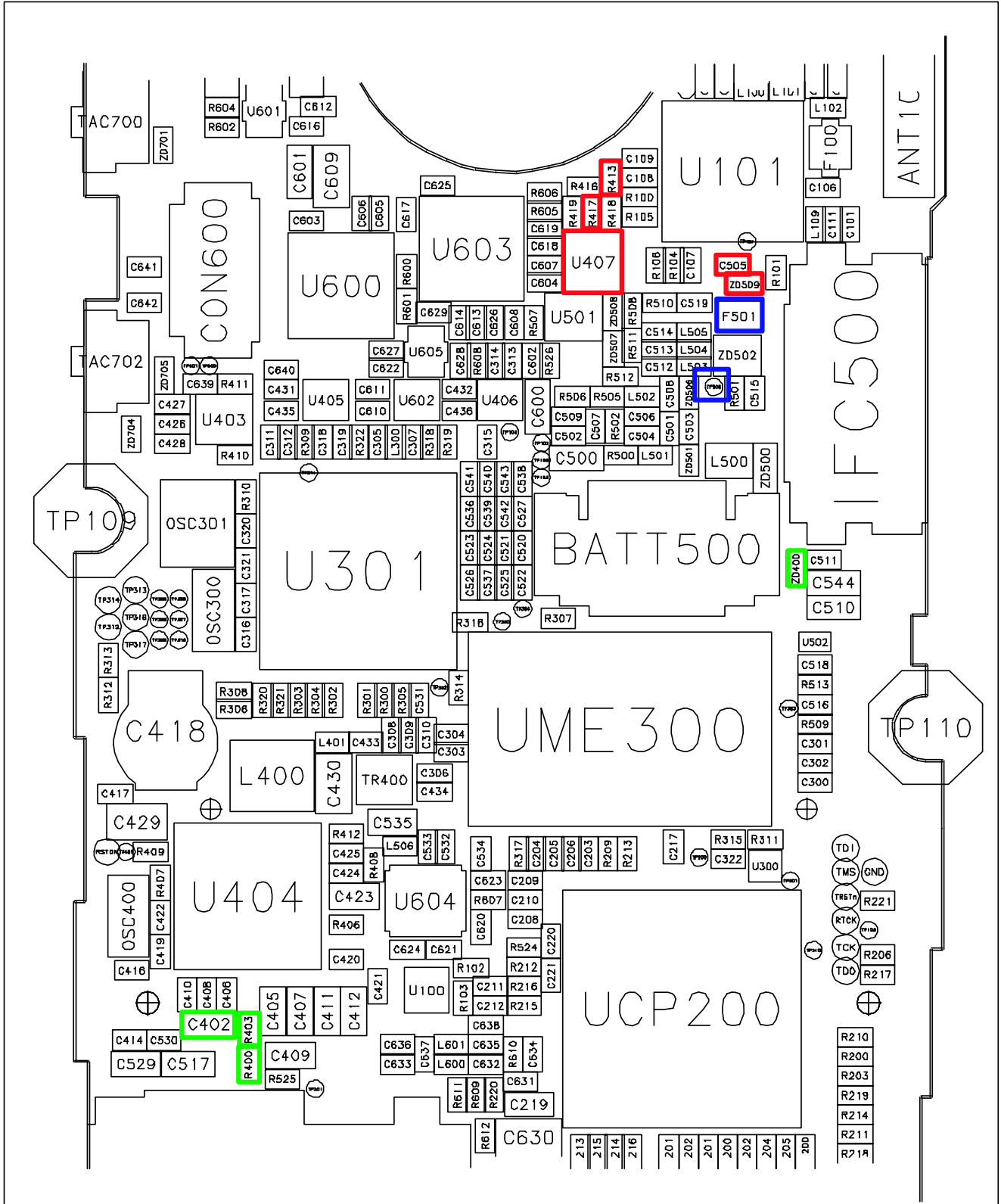

9-4. Sim Part

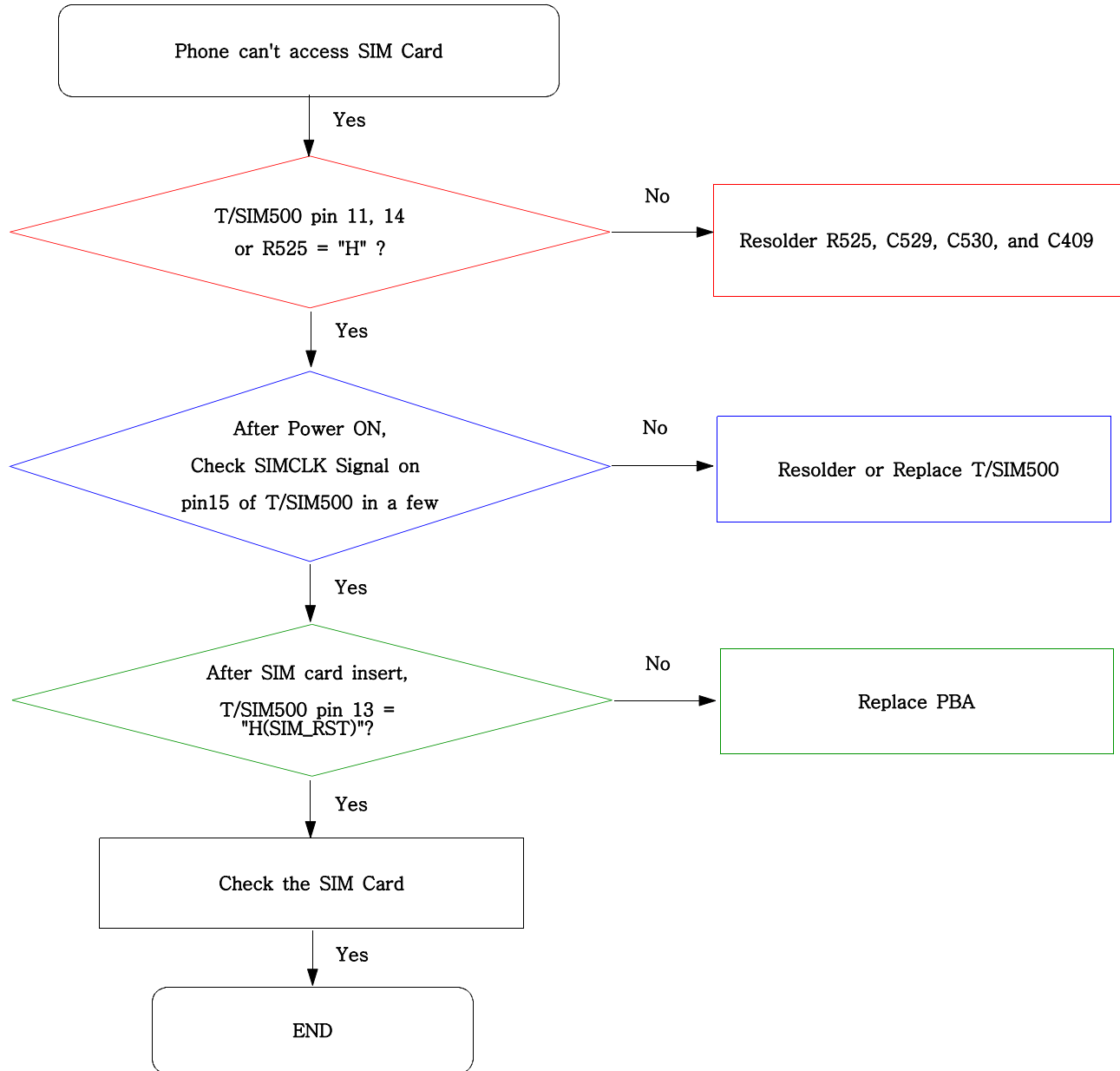

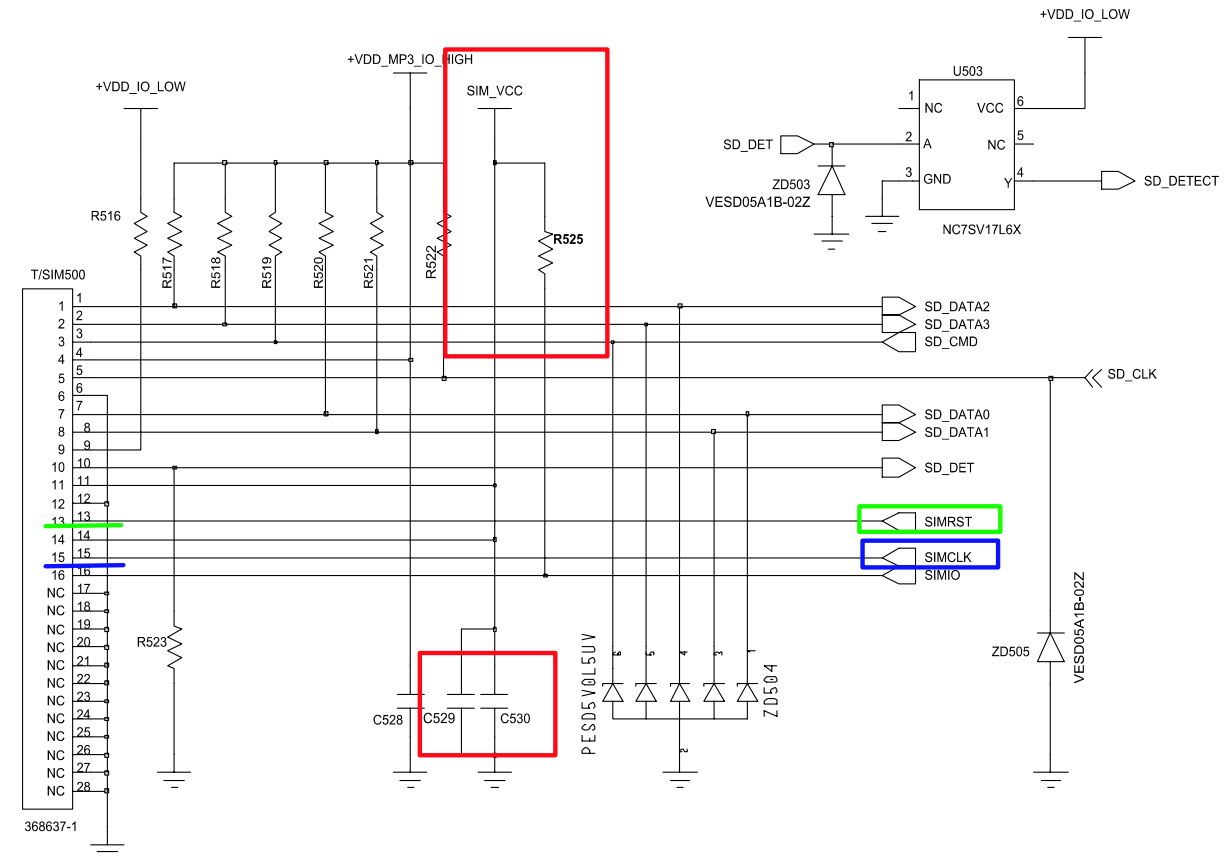

T_FLASH & SIM

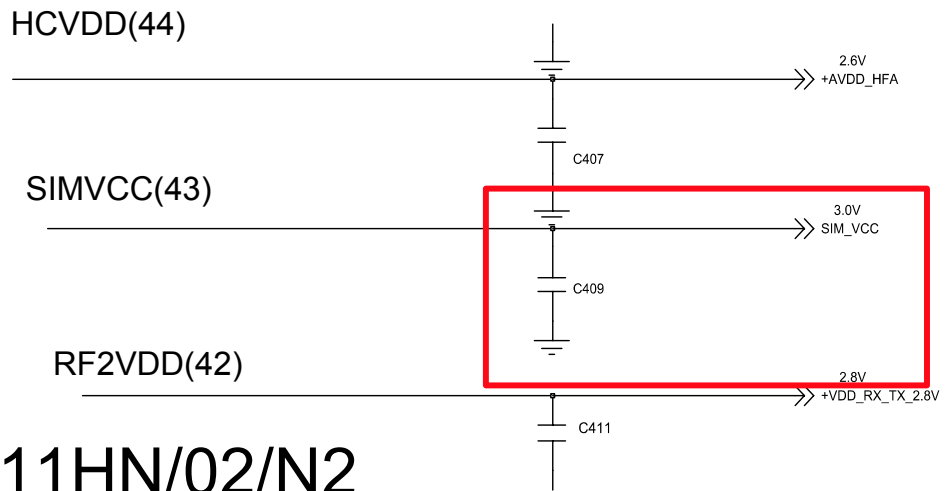

U404
PCF50611HN/02/N2

9-5. Microphone Part

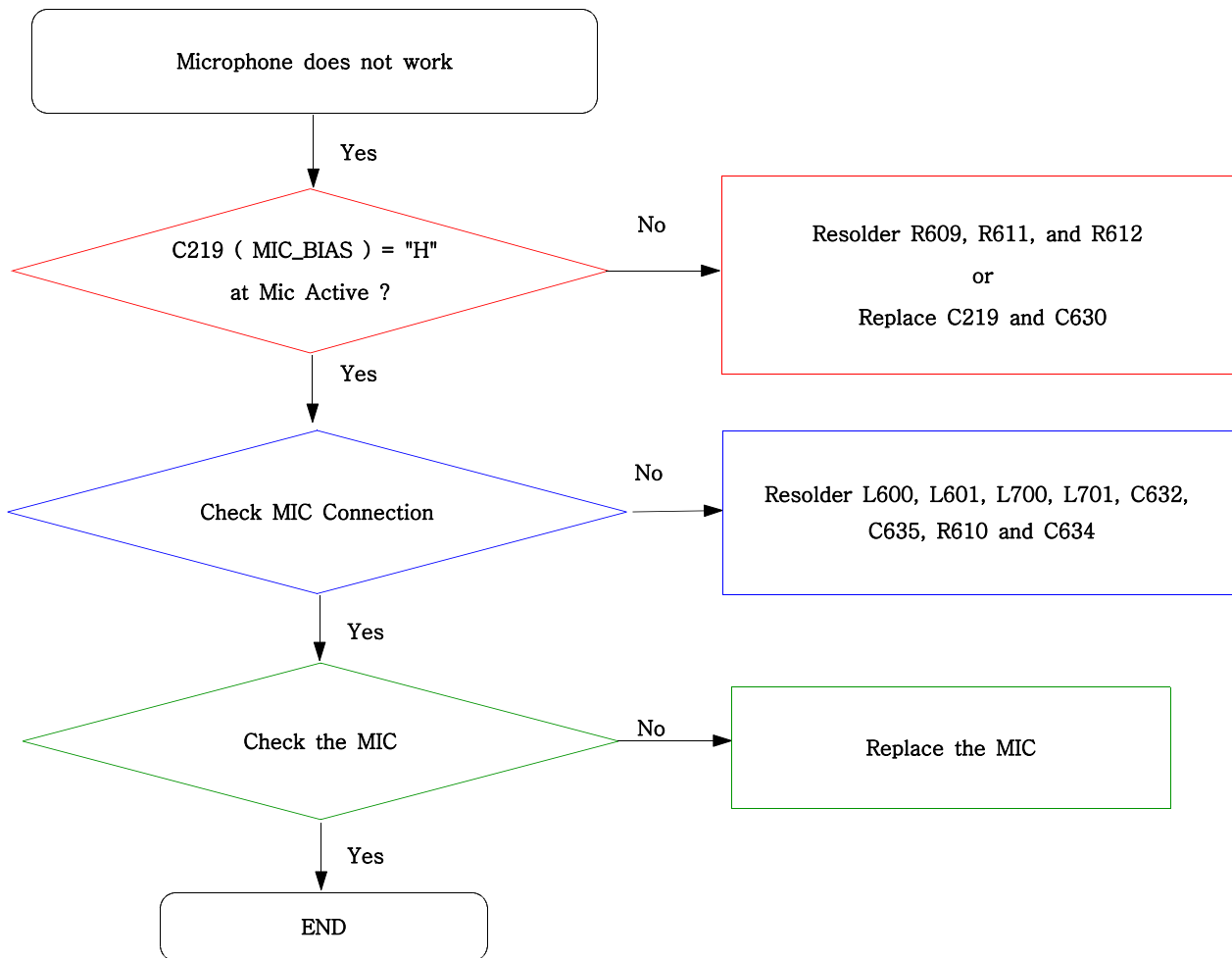

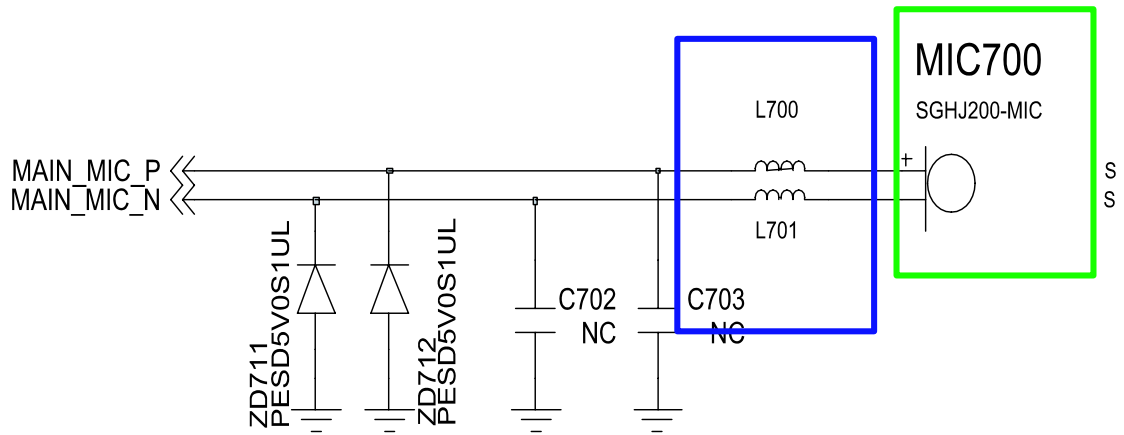
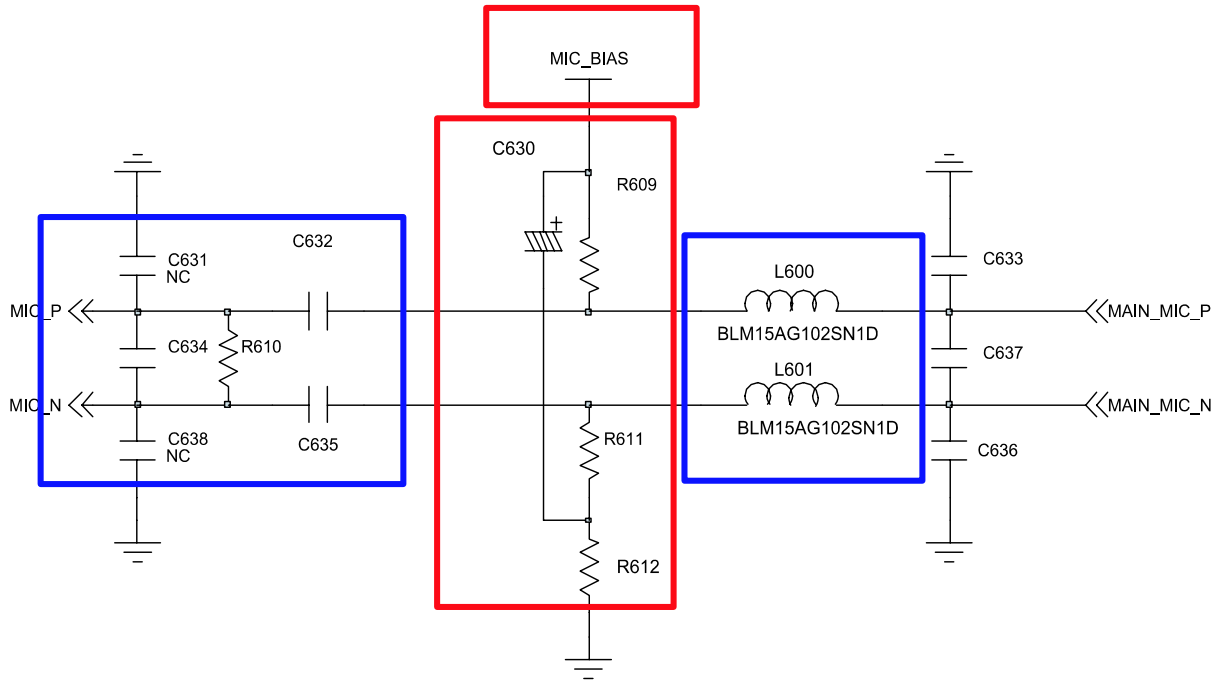

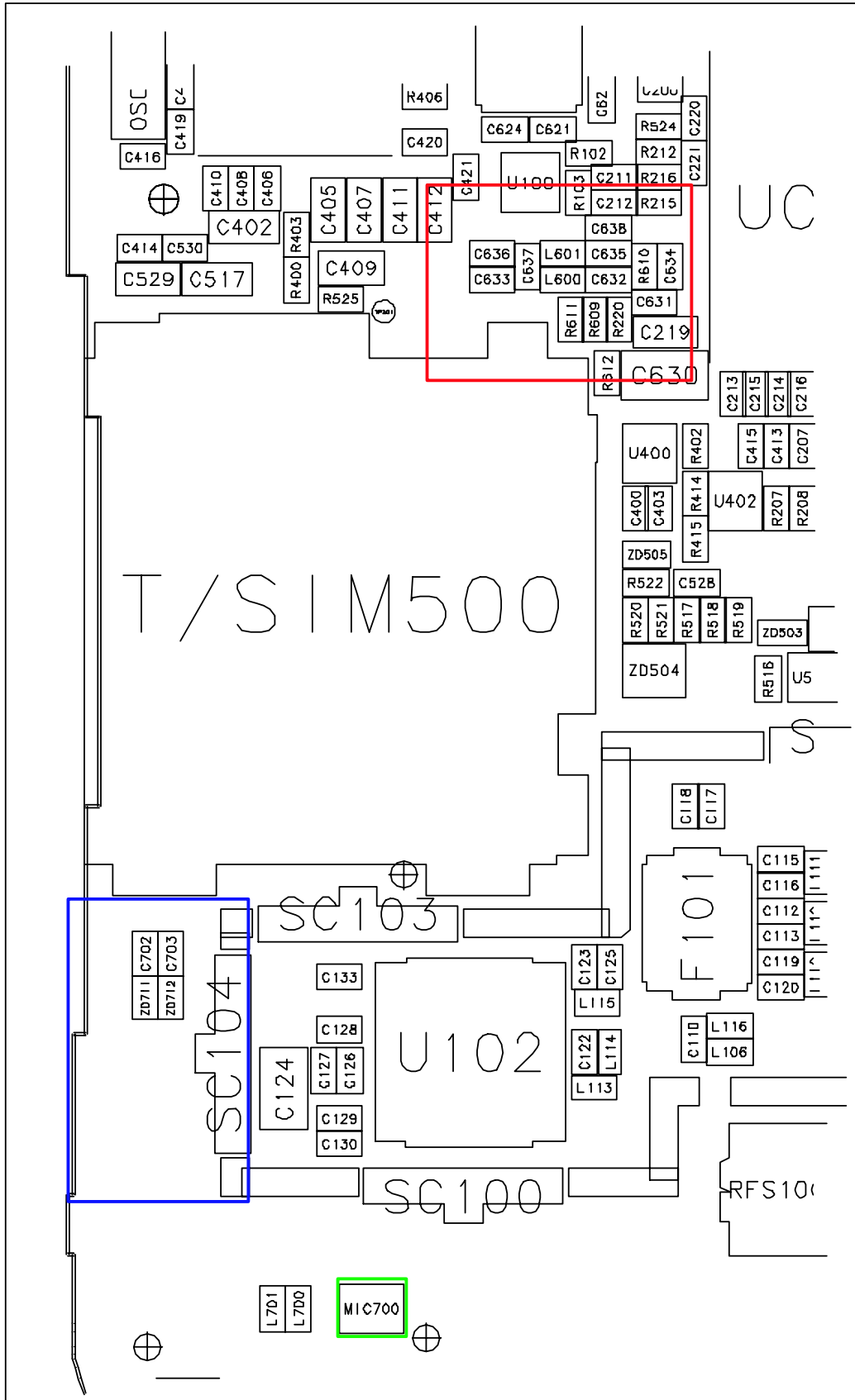

9-6. Speaker Part

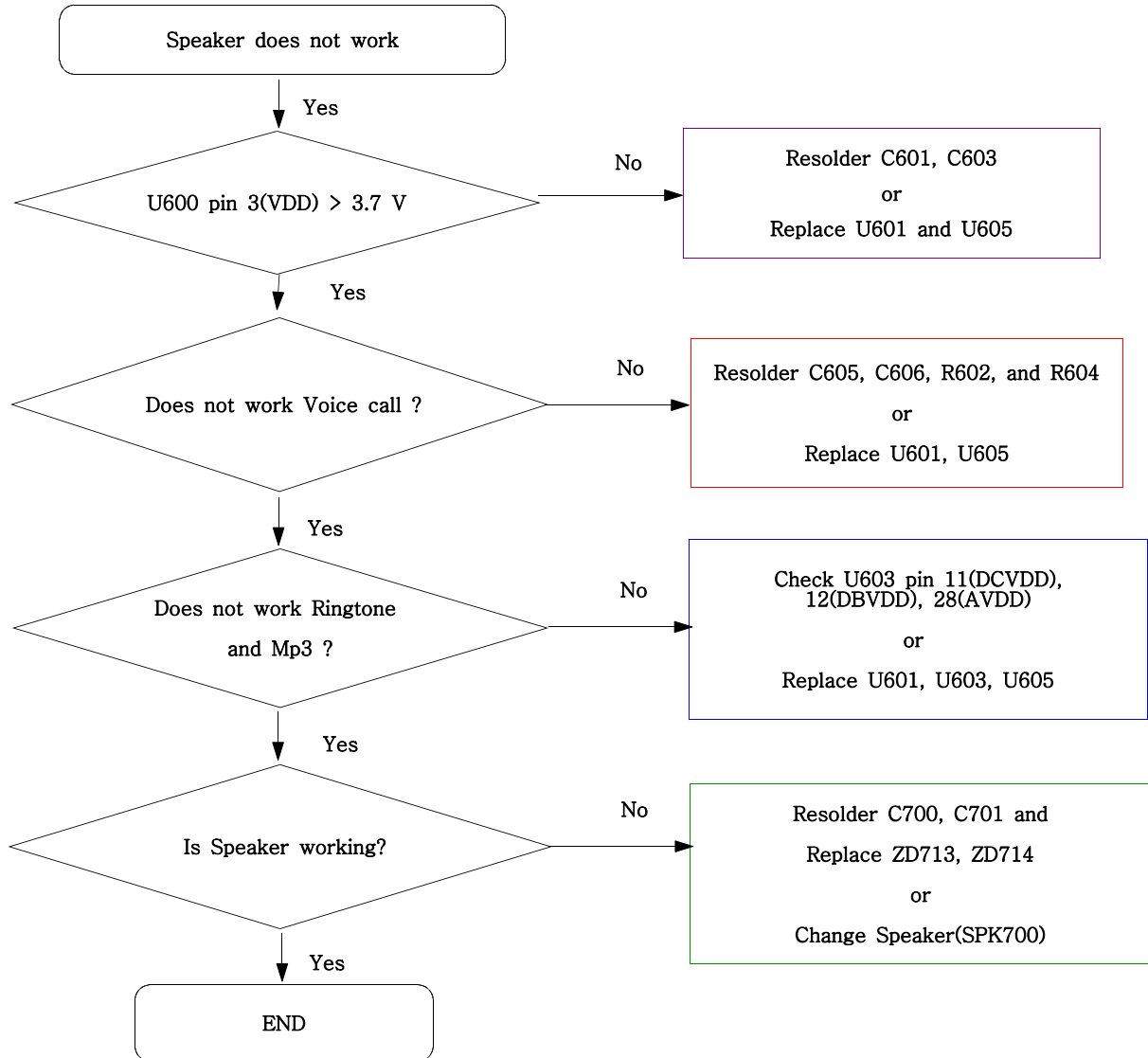

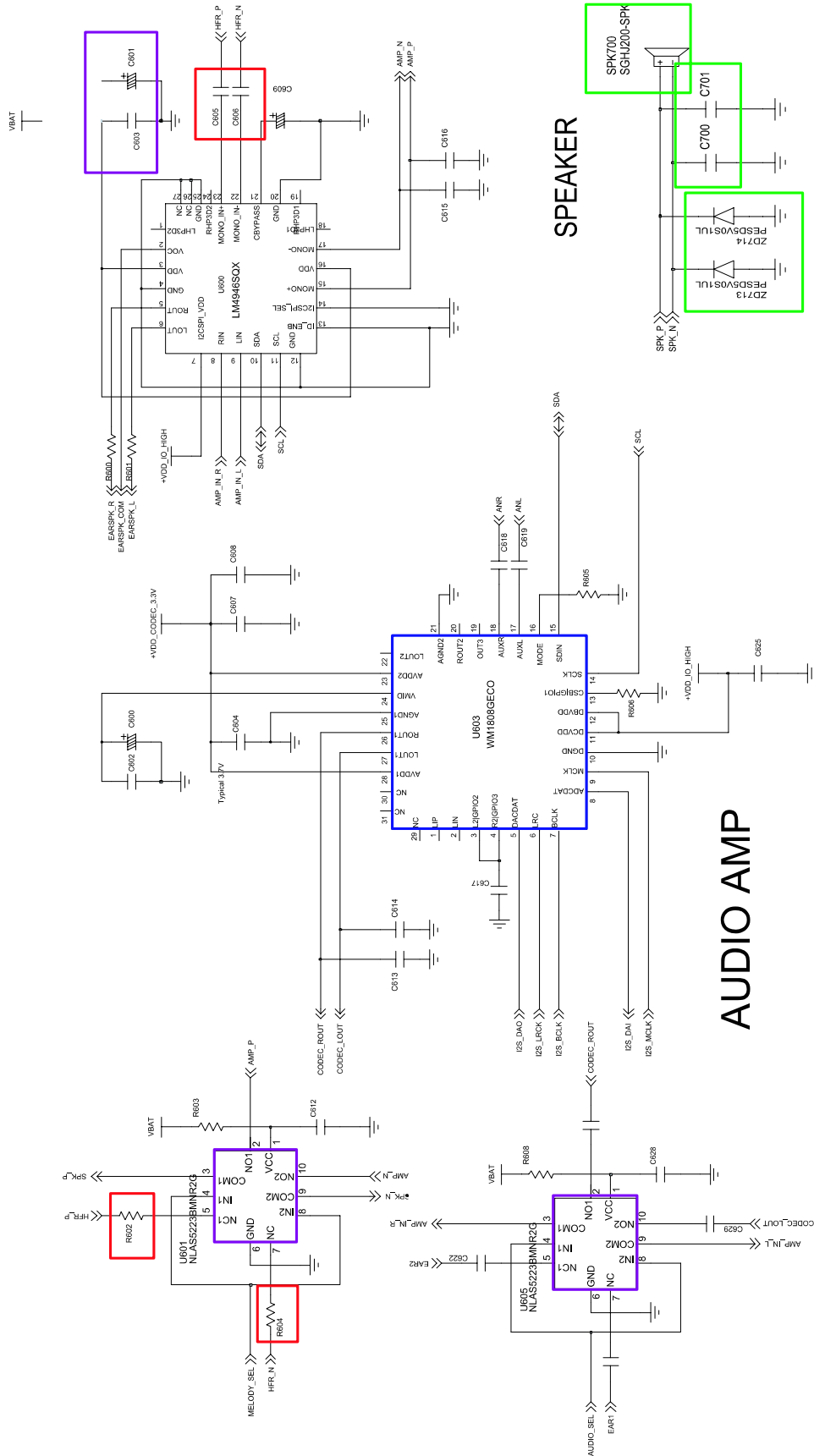

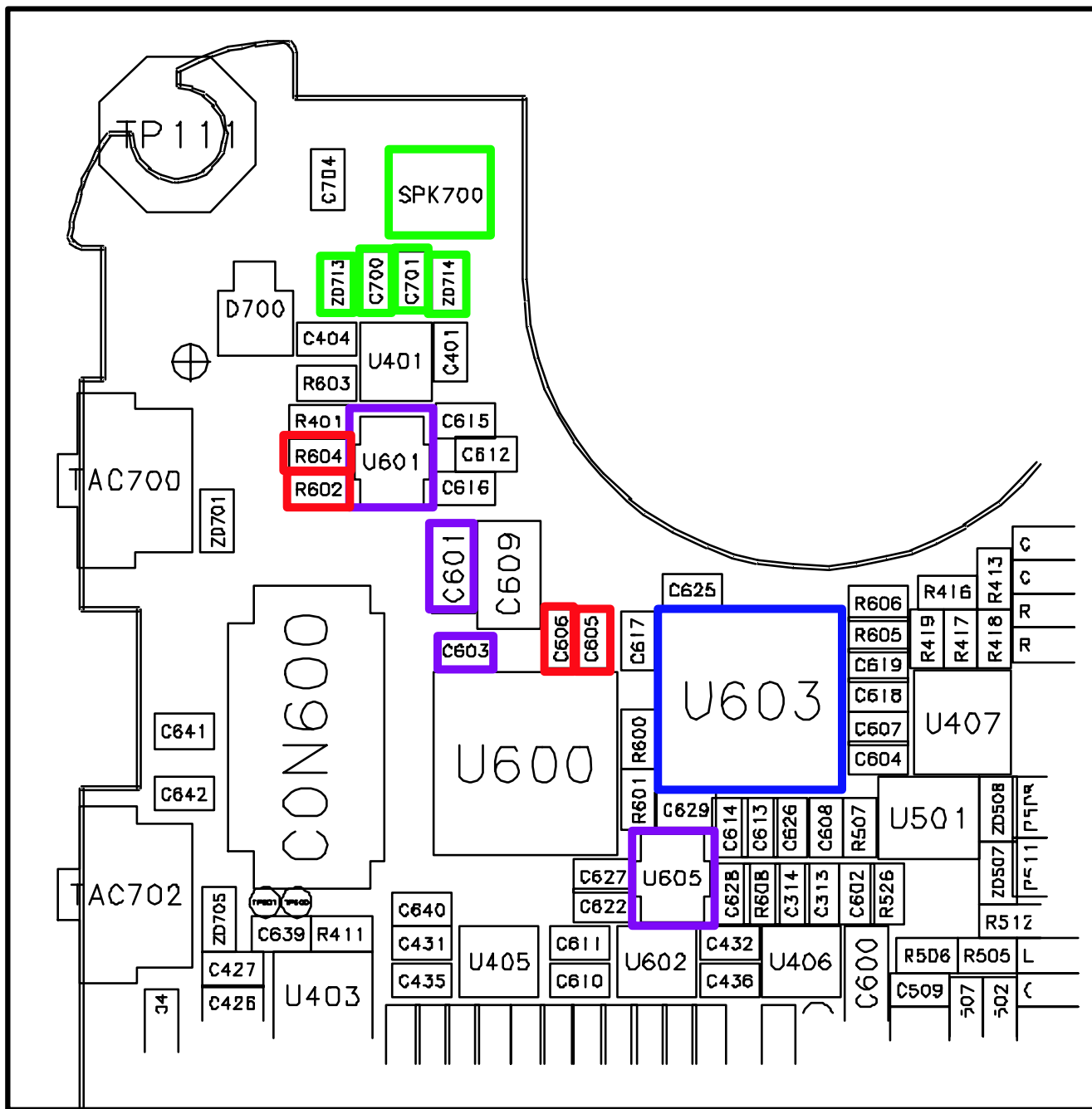

9-7. Key Data Input

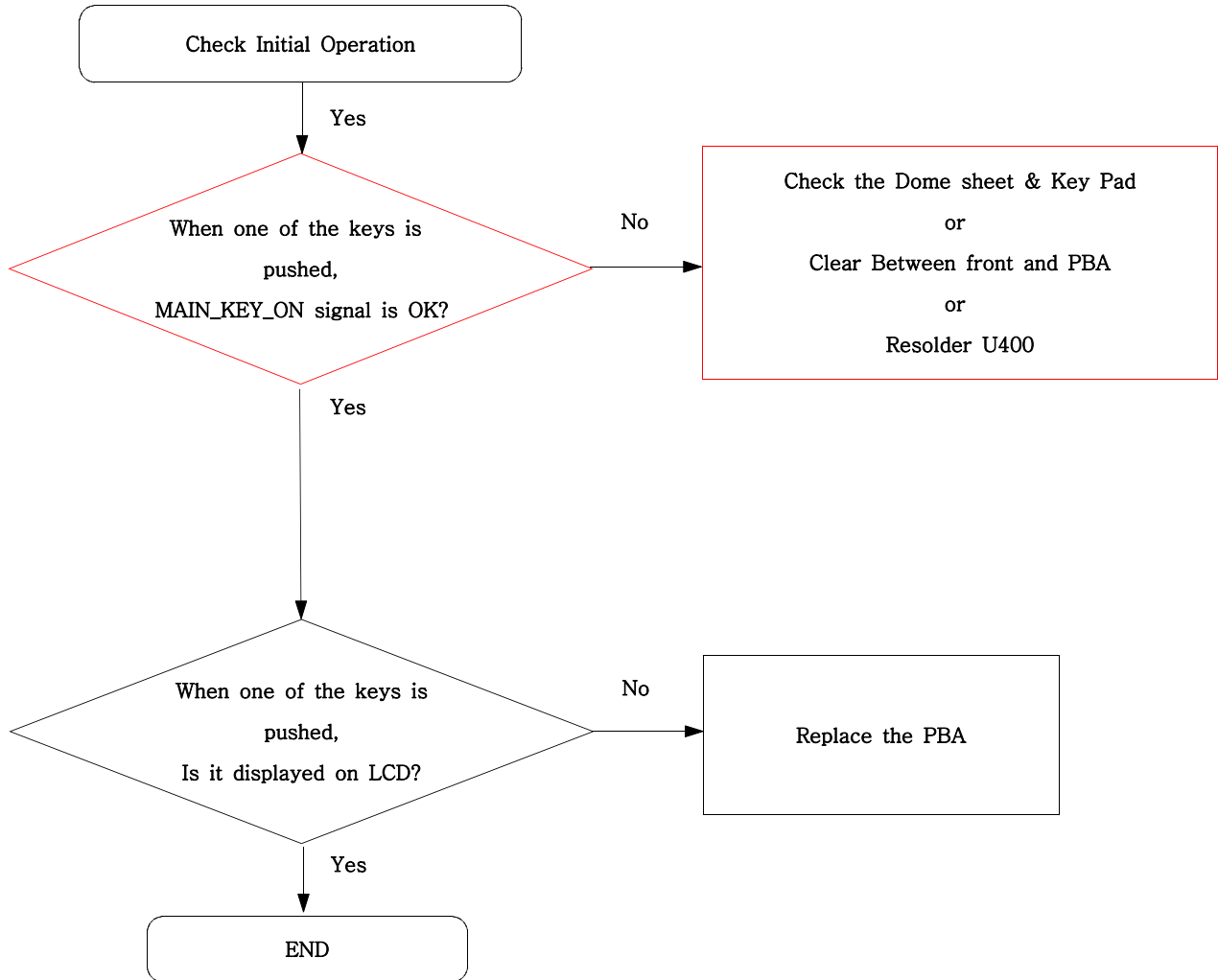

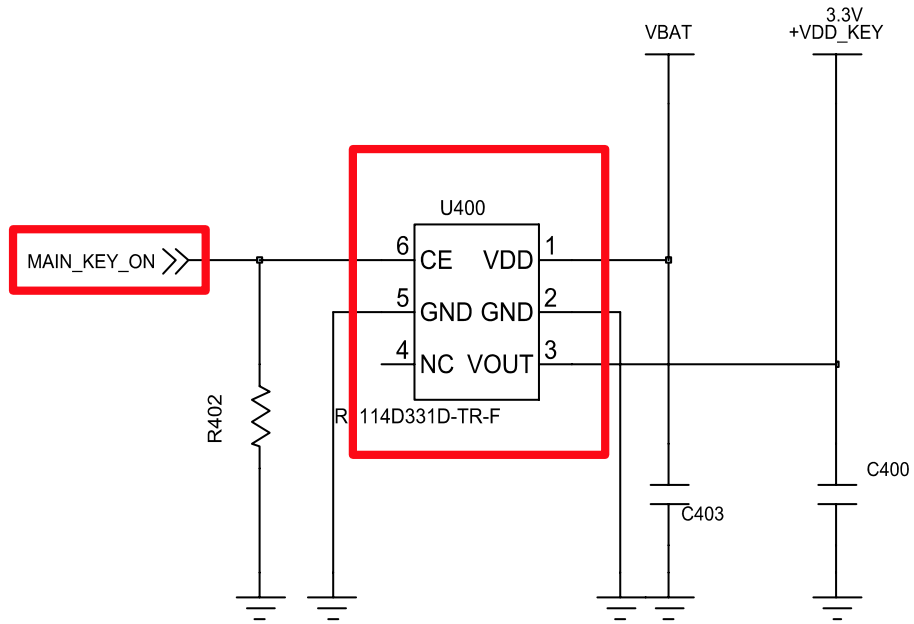

KEY

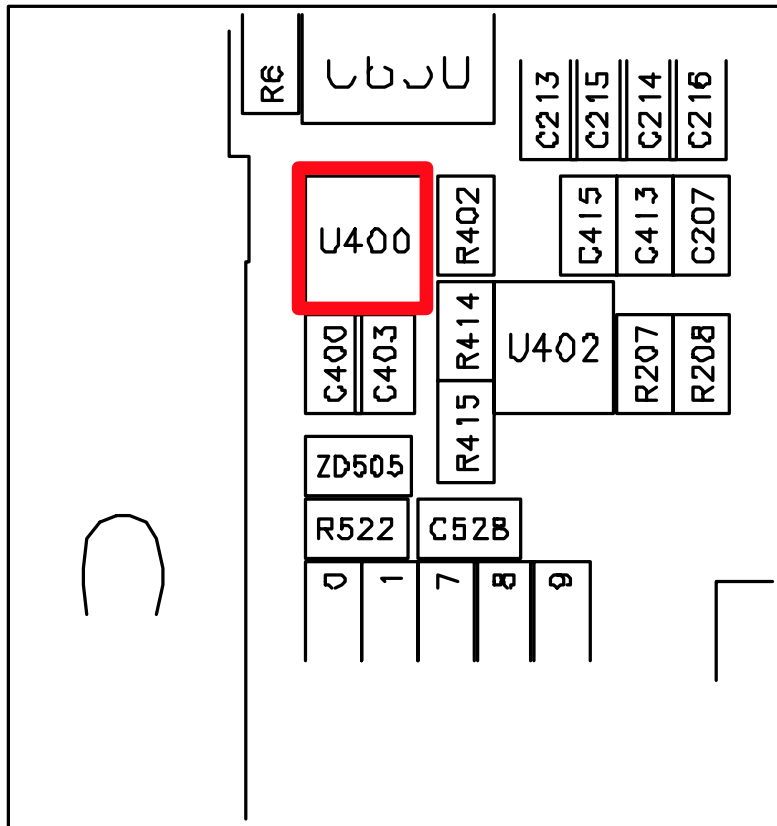

9-8. Back Light (for Color Main LCD)

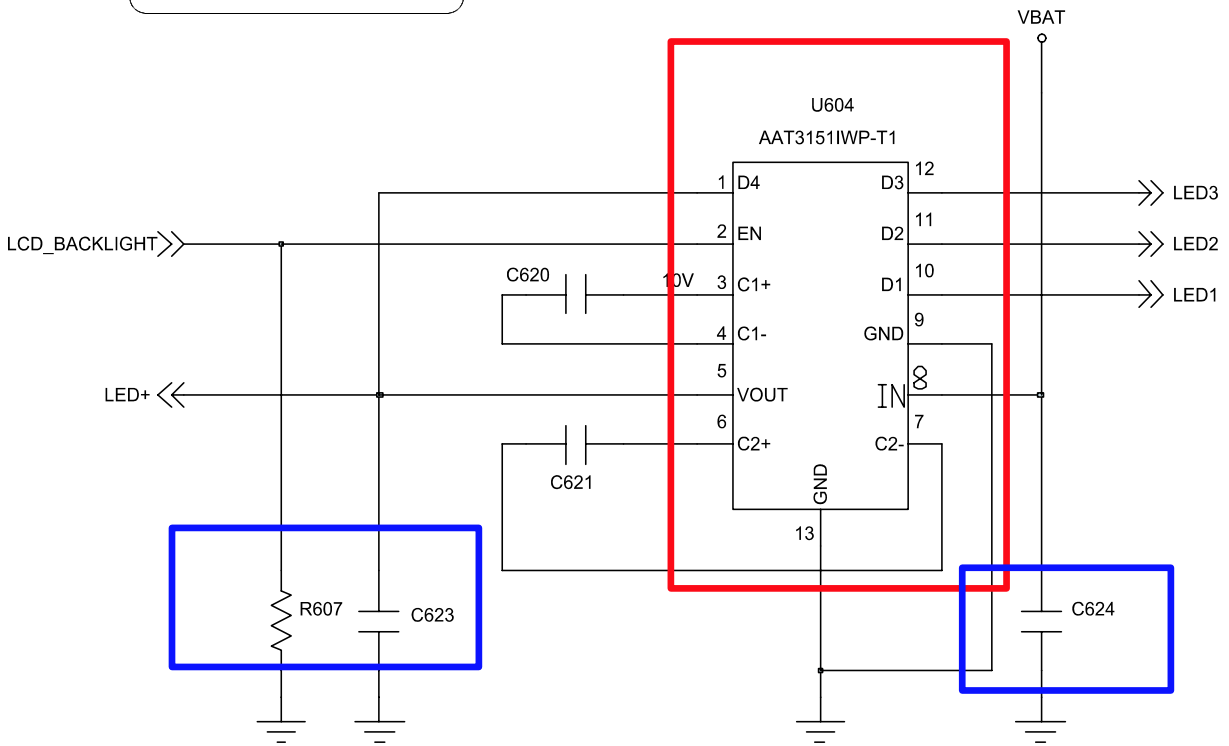
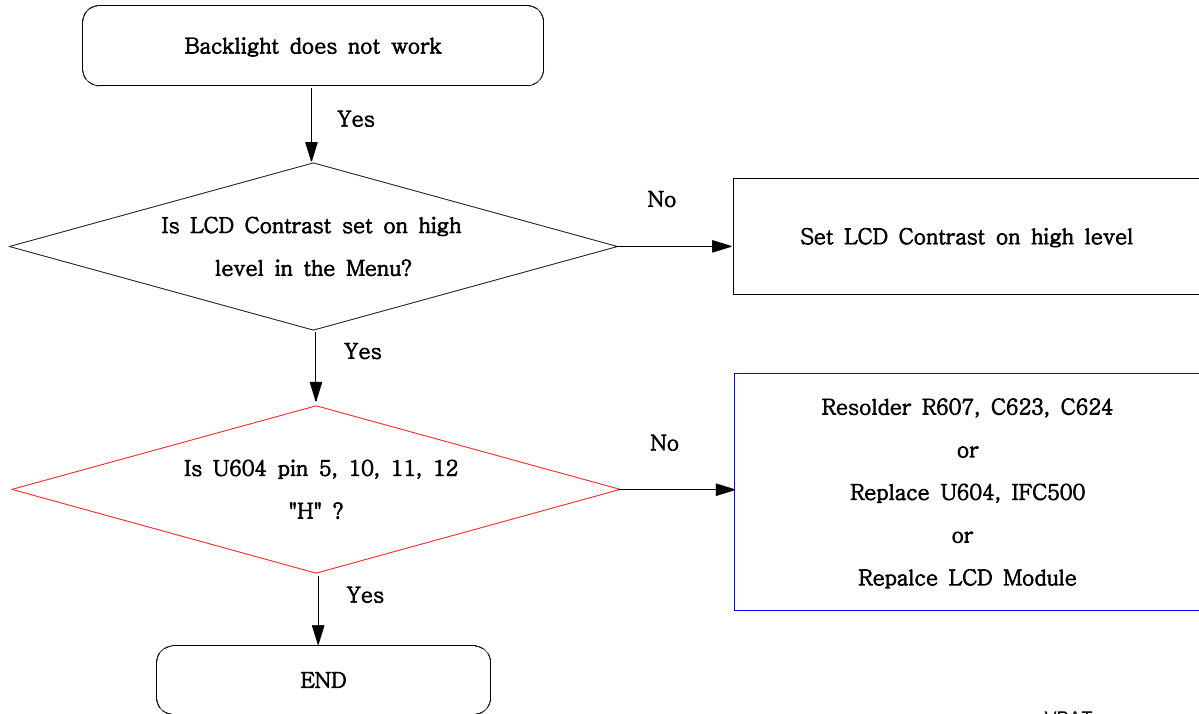

9-9. Key Back Light

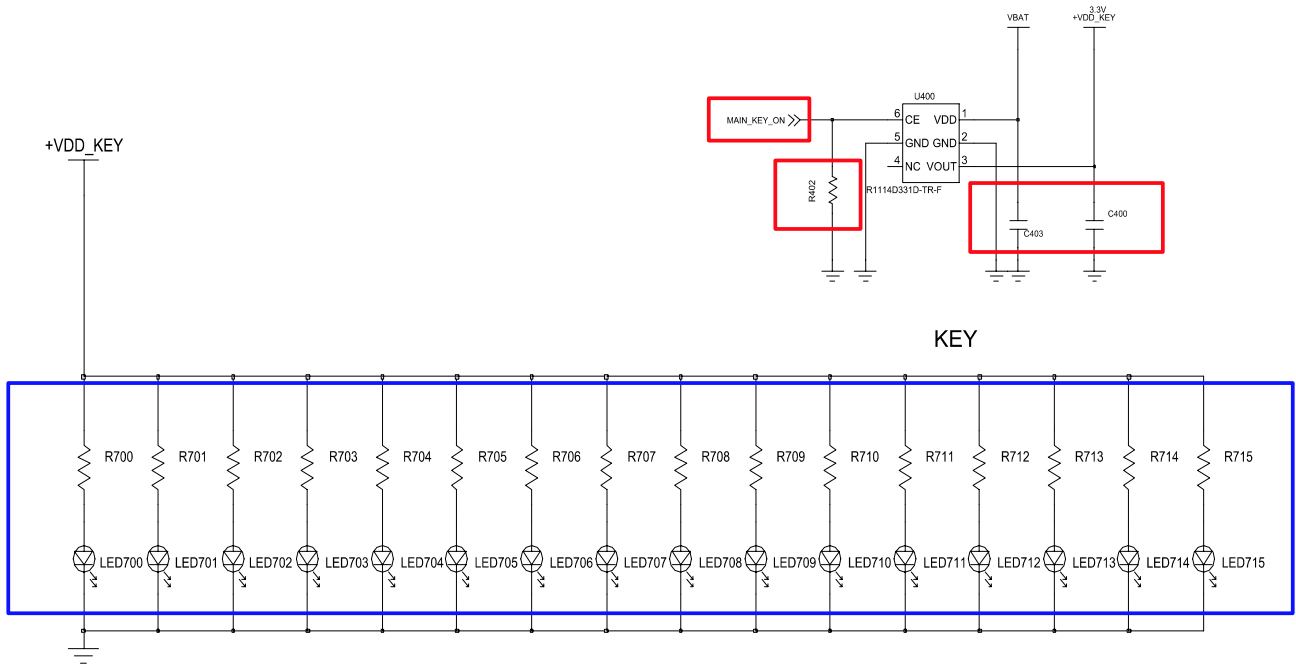
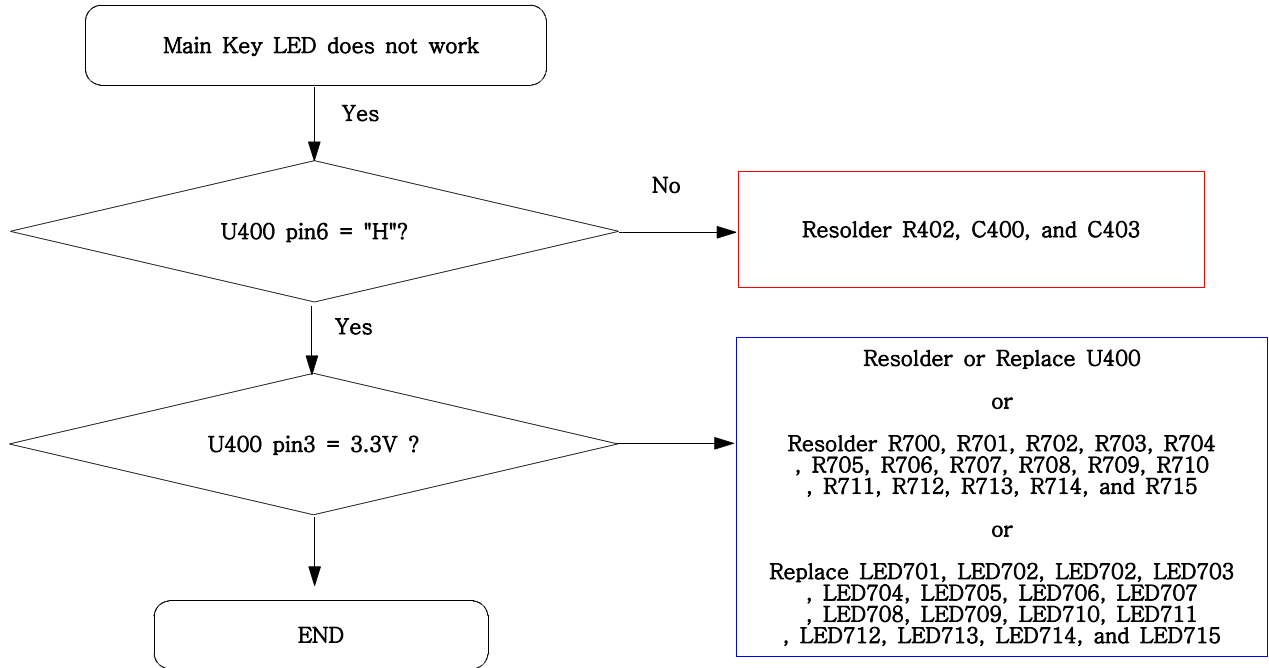

9-10. Camera part

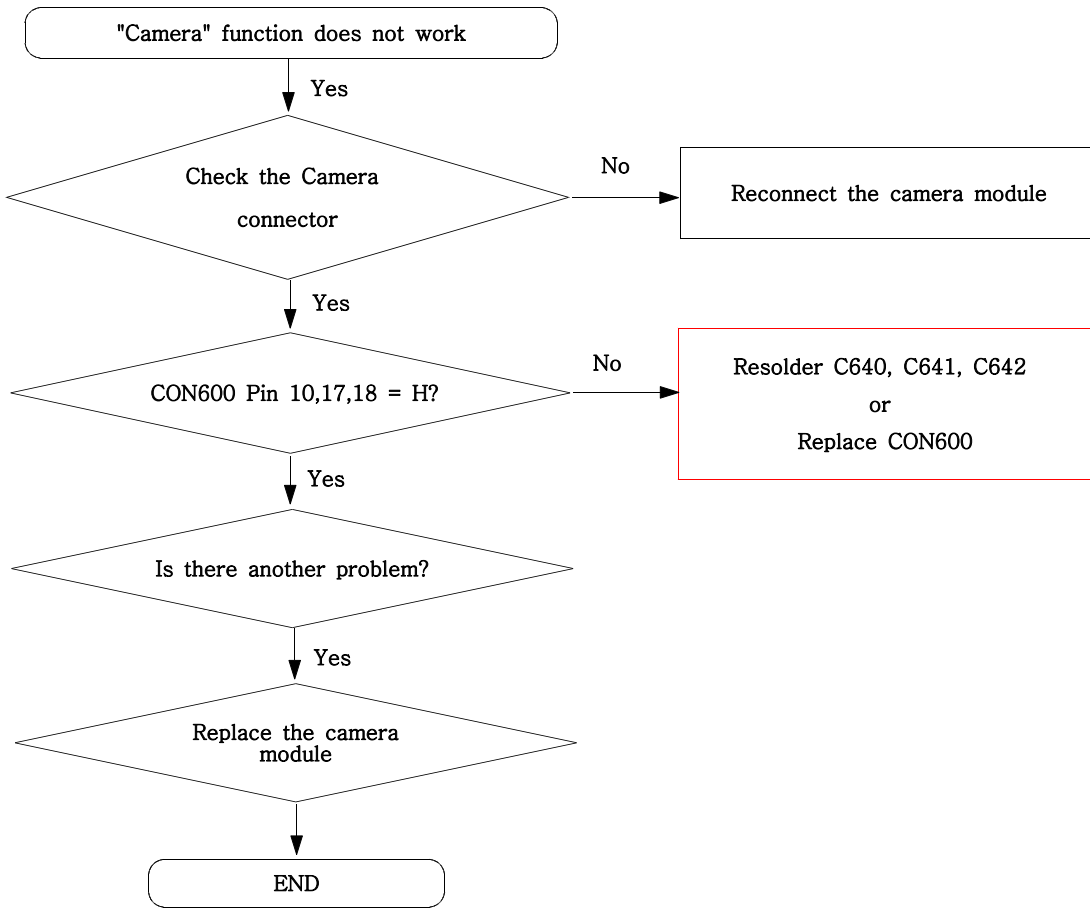

CAMERA CONNECTOR

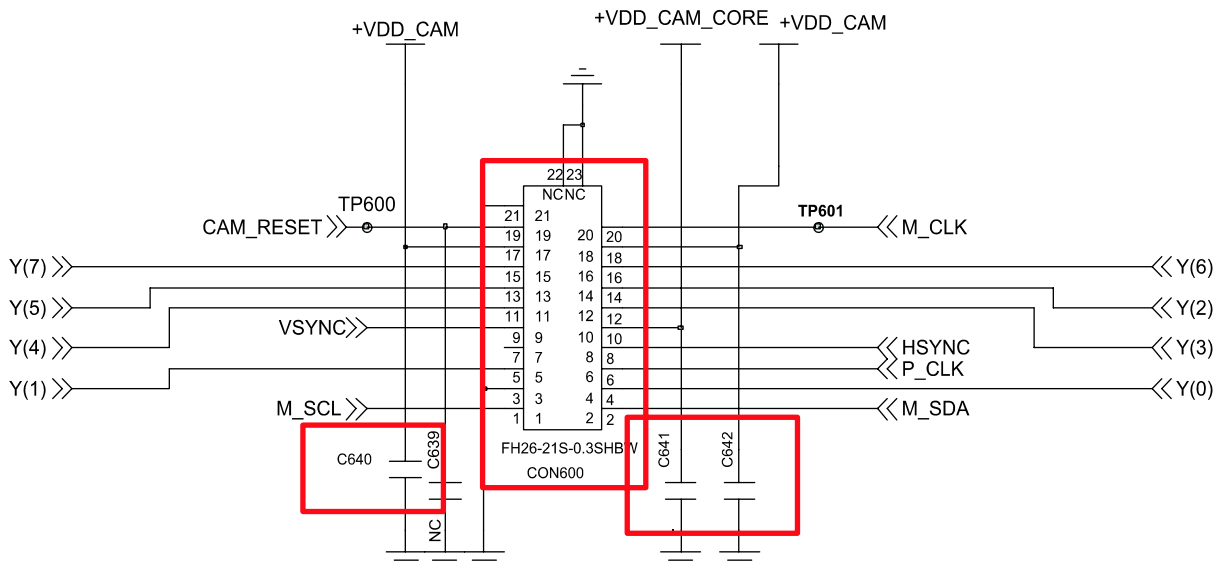

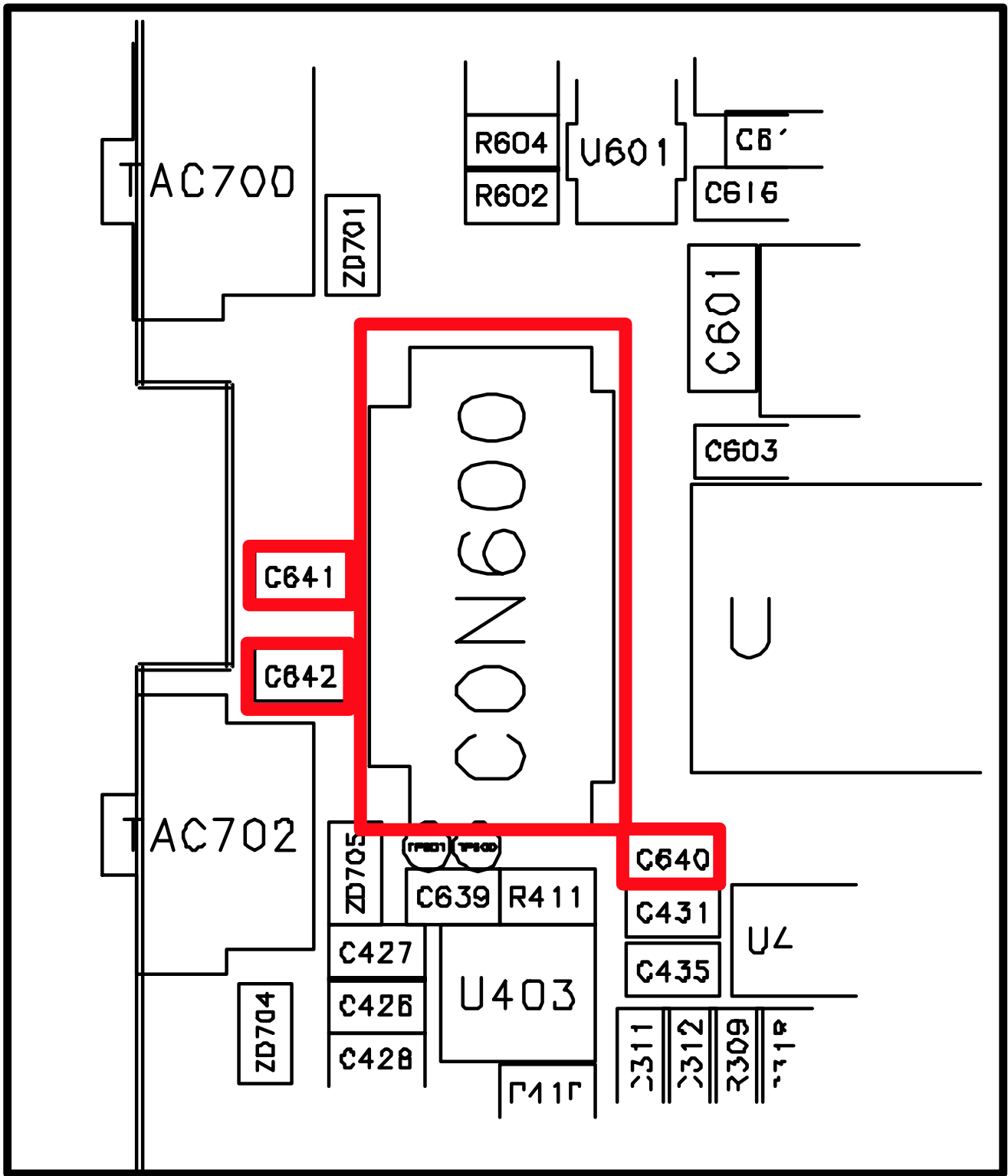

9-11. Radio Part

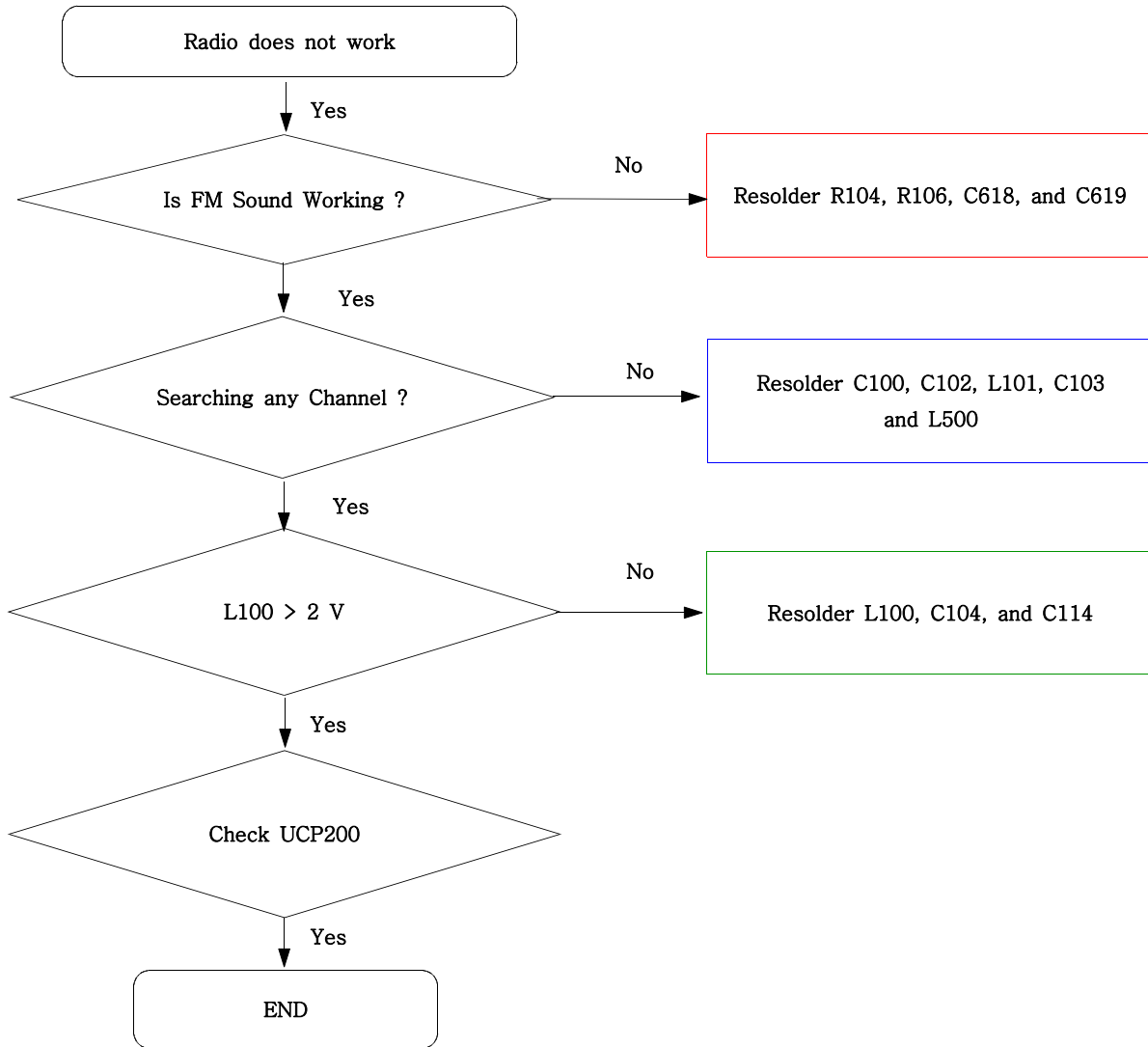

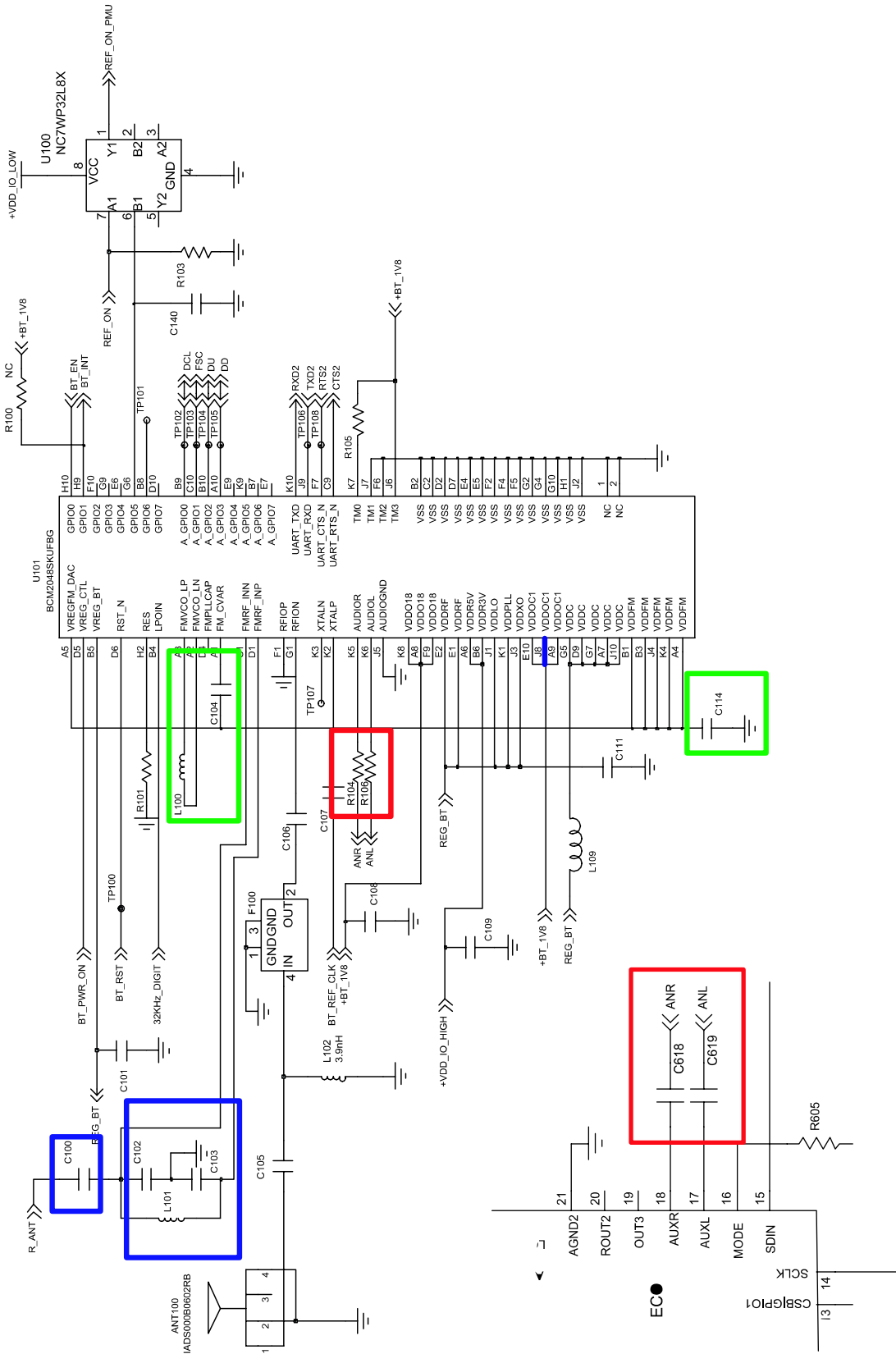

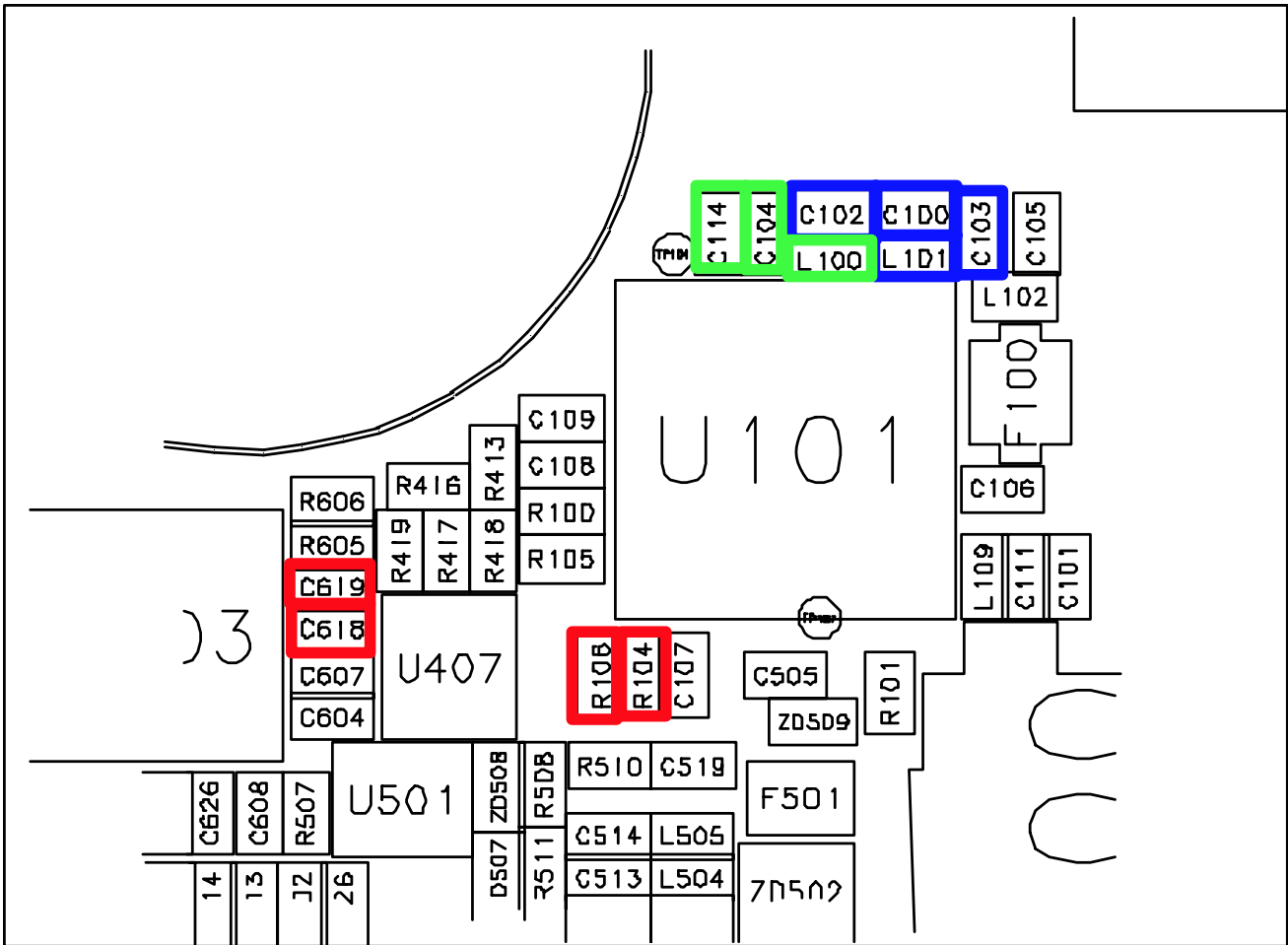

9-13. GSM Receiver

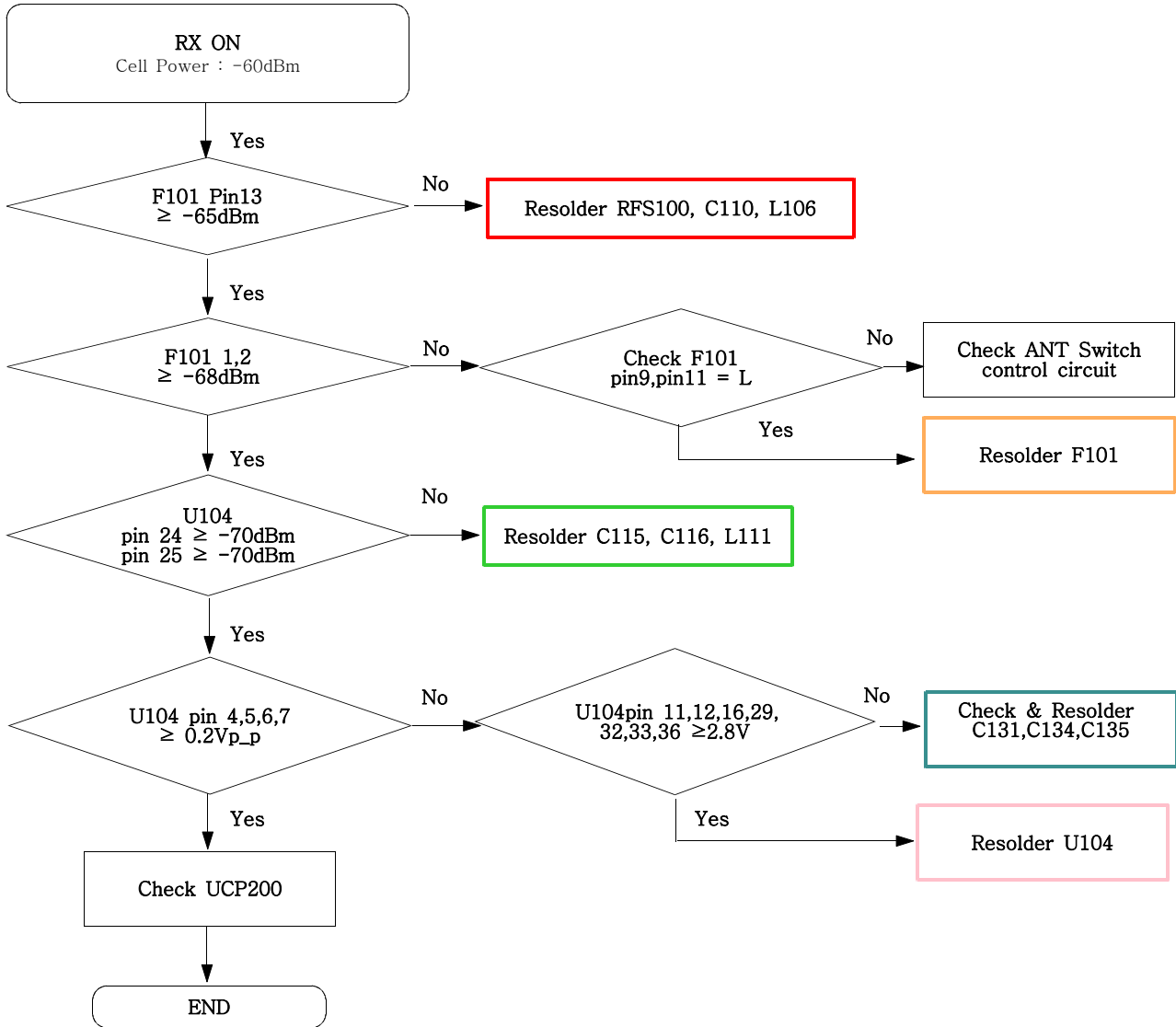

9-14. GSM Transmitter

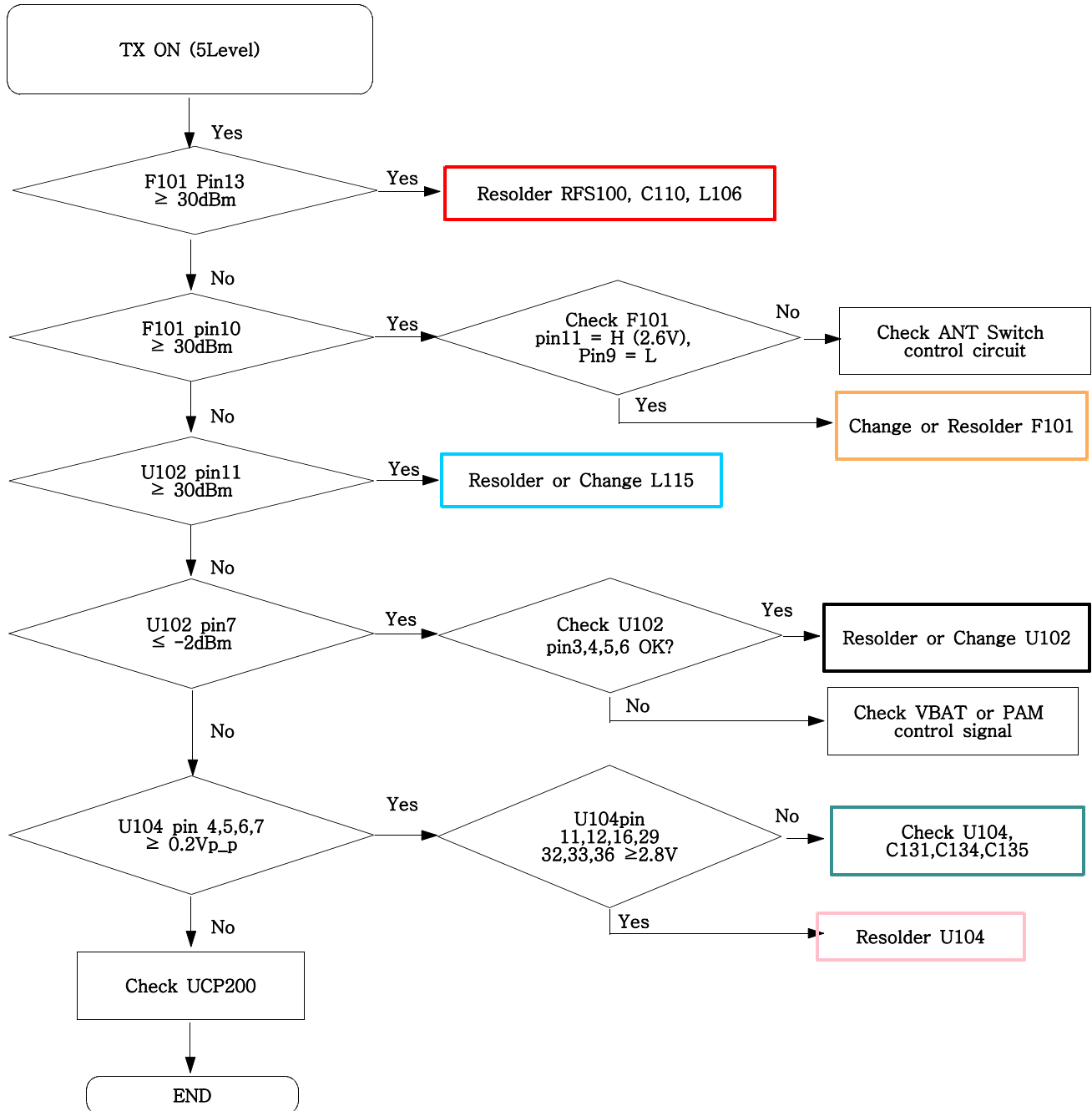

9-15. DCS Receiver

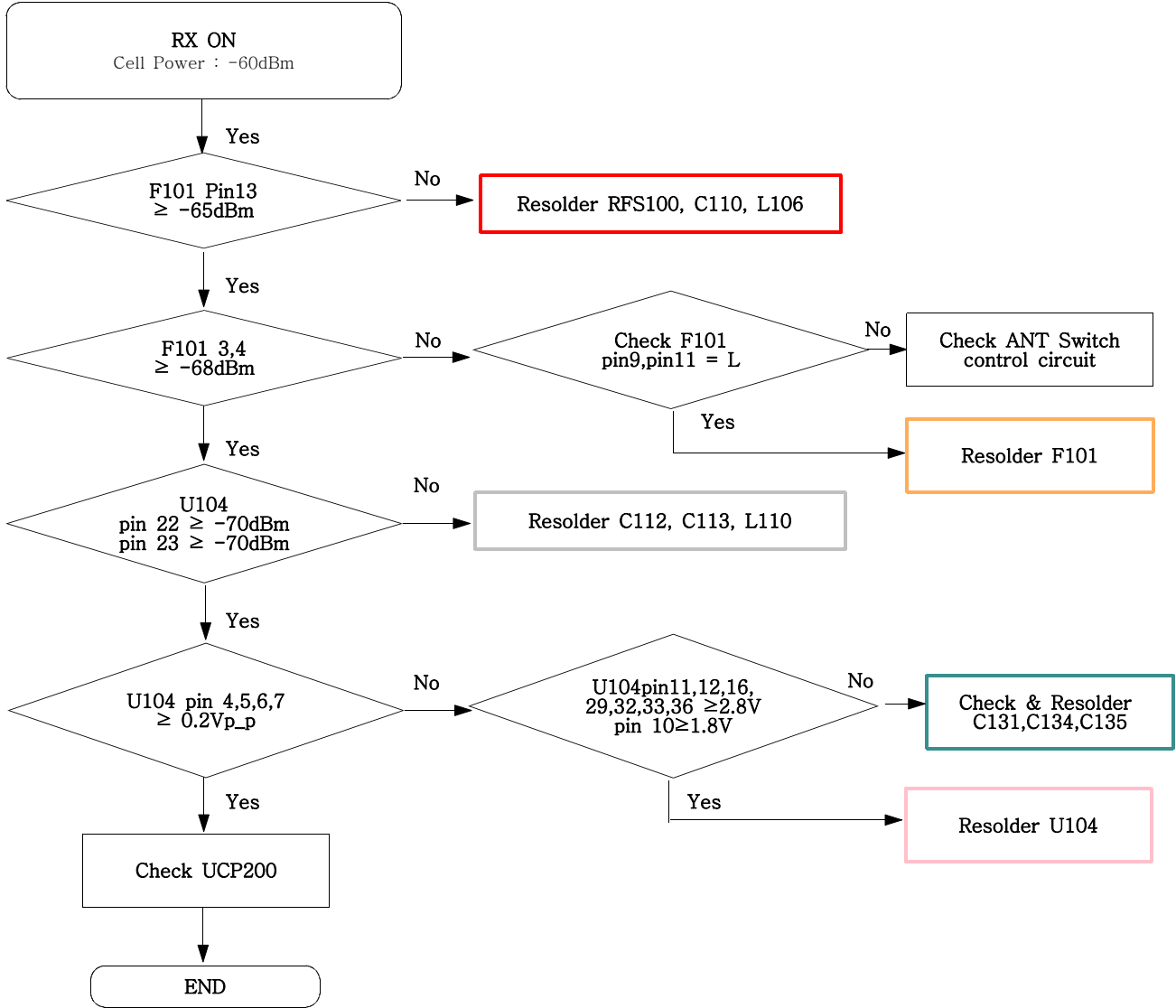

9-16. DCS Transmitter

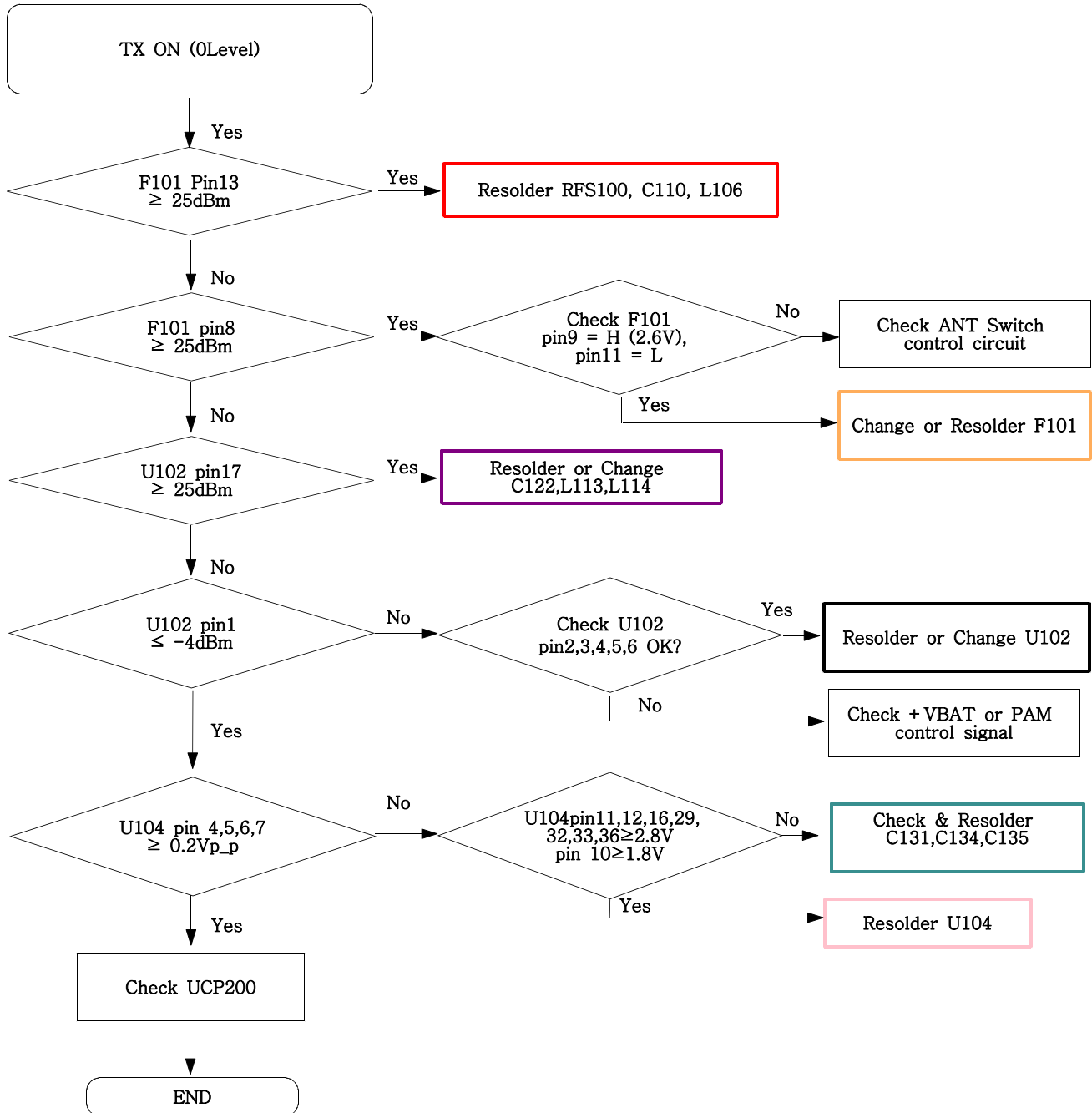

9-17. PCS Receiver

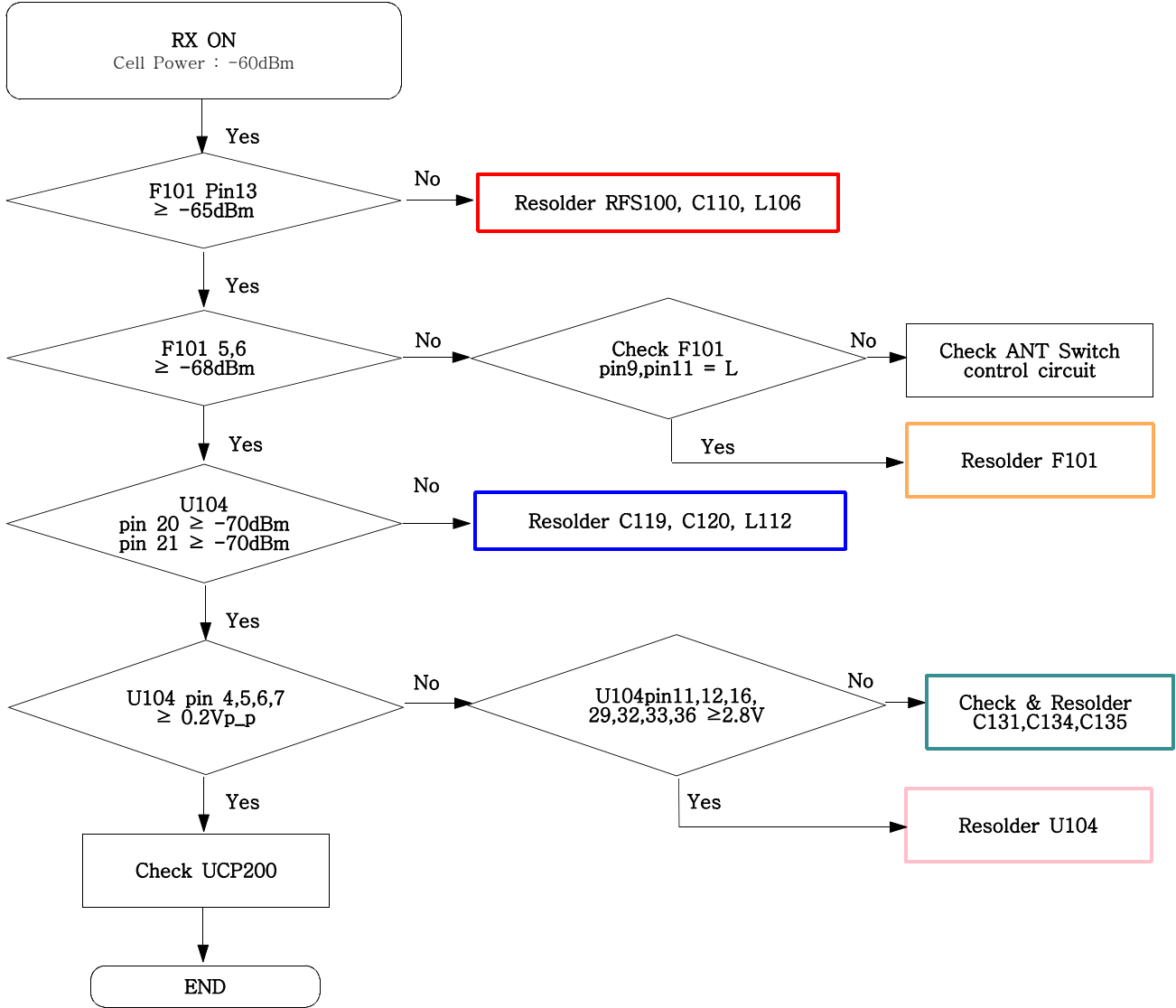

9-18. PCS Transmitter

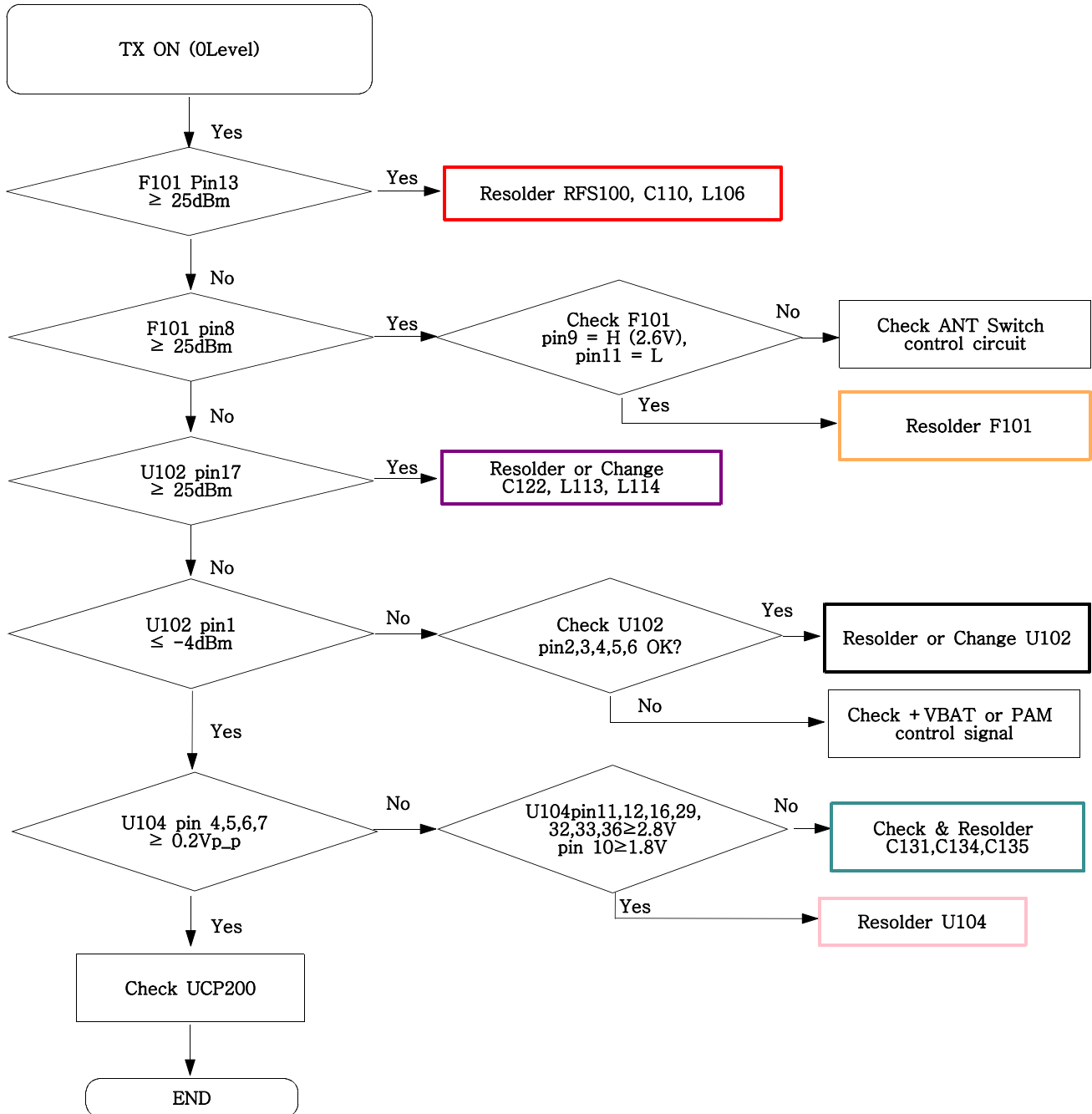

9-19. Bluetooth part

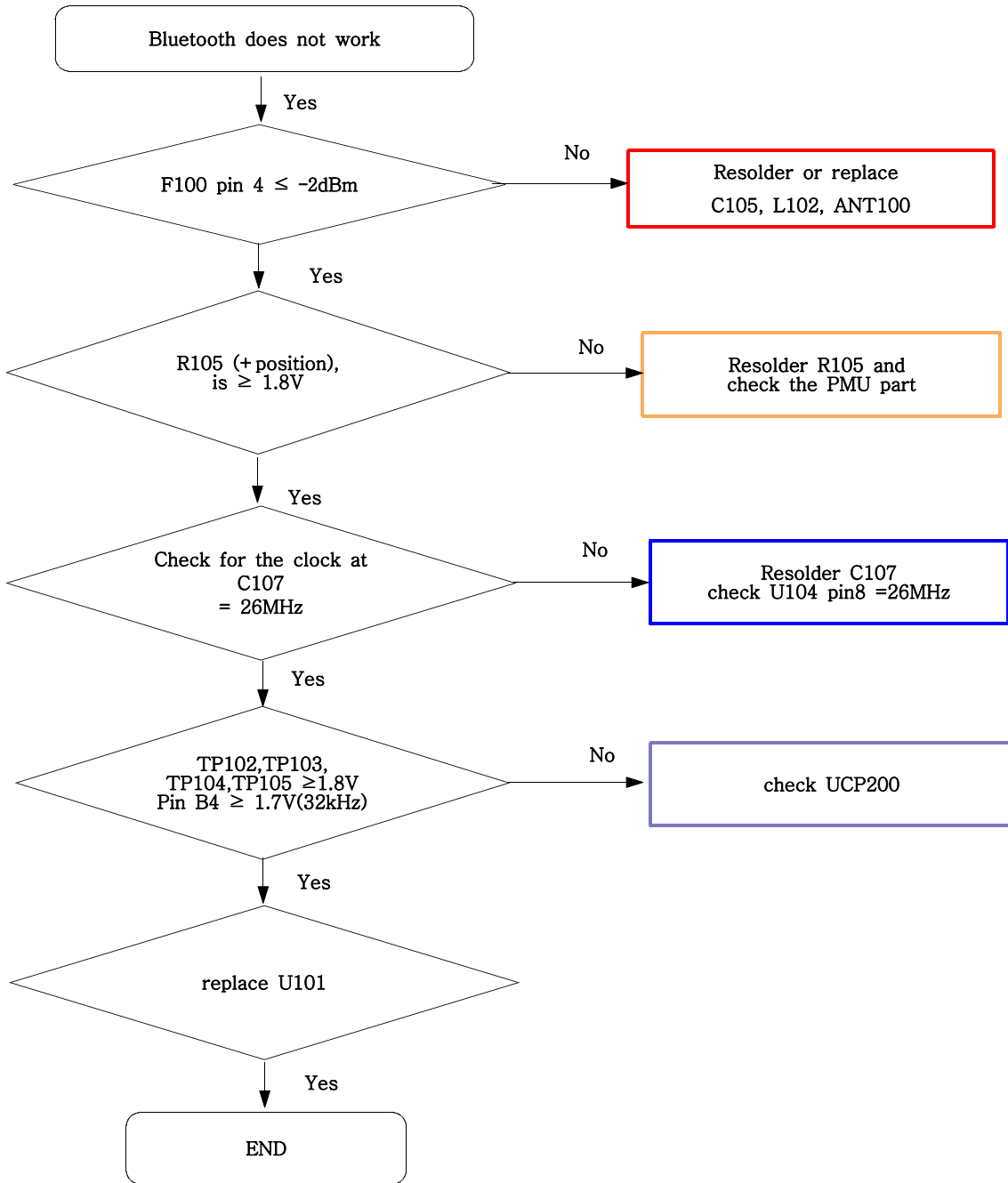

10. Reference data

Reference Abbreviate

- **AAC**: Advanced Audio Coding.
- **AVC** : Advanced Video Coding.
- **BER** : Bit Error Rate
- **BPSK**: Binary Phase Shift Keying
- **CA** : Conditional Access
- **CDM** : Code Division Multiplexing
- **C/I** : Carrier to Interference
- **DMB** : Digital Multimedia Broadcasting
- **EN** : European Standard
- **ES** : Elementary Stream
- **ETSI**: European Telecommunications Standards Institute
- **MPEG**: Moving Picture Experts Group
- **PN** : Pseudo-random Noise
- **PS** : Pilot Symbol
- **QPSK**: Quadrature Phase Shift Keying
- **RS** : Reed-Solomon
- **SI** : Service Information
- **TDM** : Time Division Multiplexing
- **TS** : Transport Stream

11. Disassembly and Assembly Instructions

11-1. Disassembly Instructions

1

1) Release SCREW 6 POINT at Rear

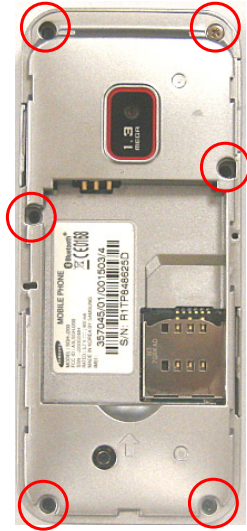

1) Be careful not to make scratch and molding damage!

2

1) Disjoint HOOK from up to down.



1) Be careful not to make scratch and molding damage!

3

1) Separate Speaker, Motor and Camera from Bracket.

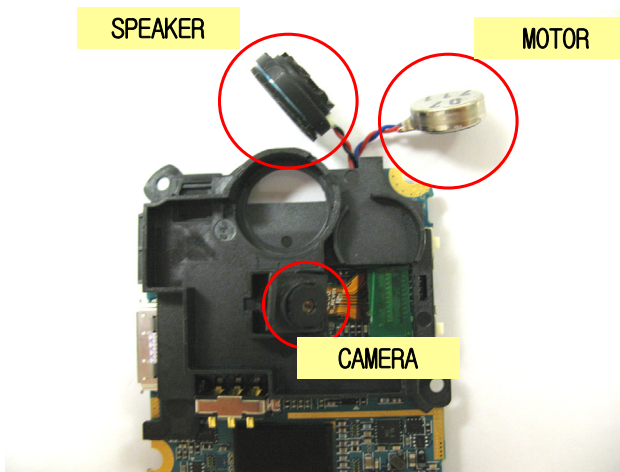

1) Be careful not to make scratch and molding damage!

4

1) Disjoint the Bracket's HOOK (3 point)

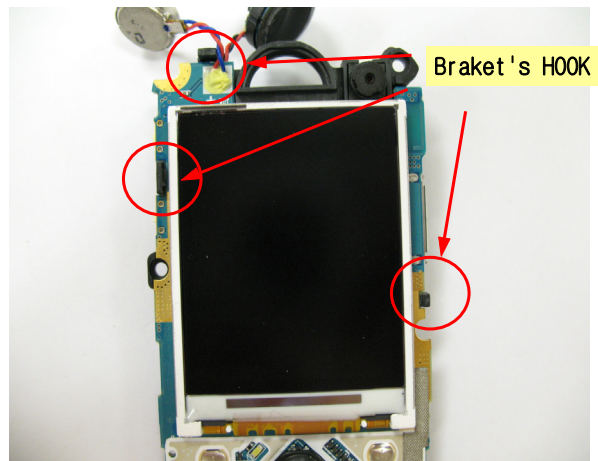

1) Be careful not to make scratch and molding damage!

5

1 Separate Bracket from the main PBA.

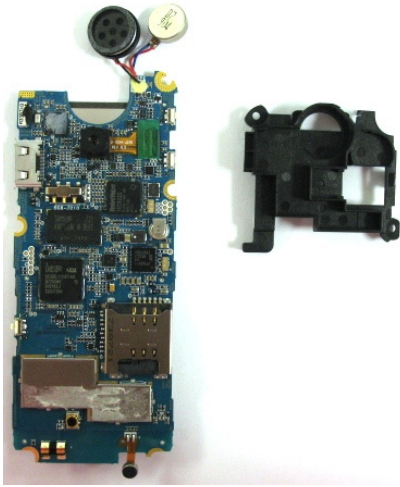

- 1) Be careful not to make scratch and molding damage!
- 2) Beware that you do not damage CAMERA F-PCB.

11-2. Assembly Instructions

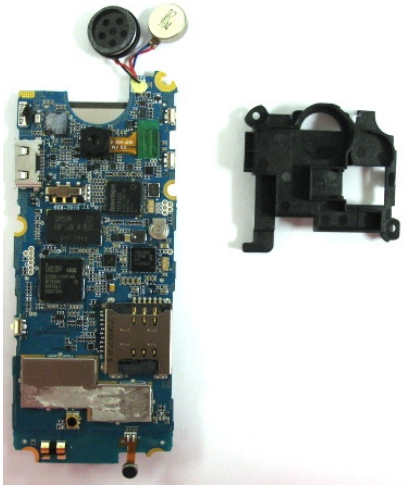
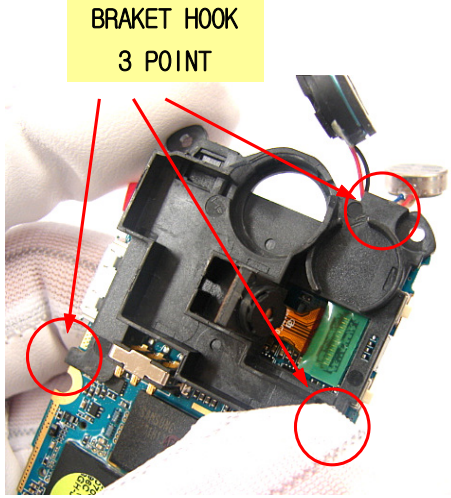
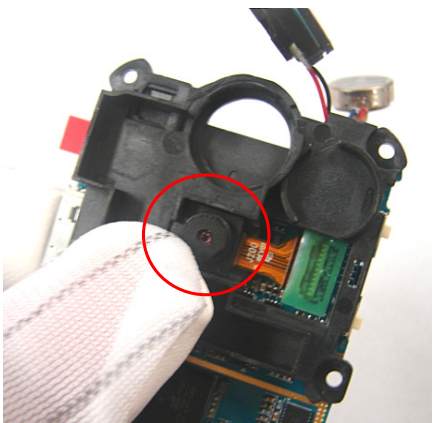
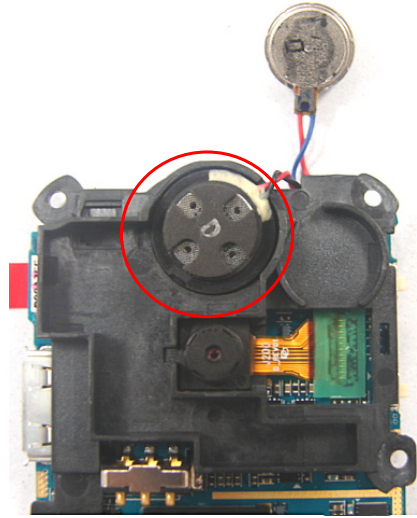
<p>1) Prepare main PBA and Braket</p> 	<p>1)Join the Braket on the PBA - There is 3 hook on the braket.</p> <p>BRACKET HOOK 3 POINT</p> 
<p>1) Be careful not to make scratch and molding damage!</p>	<p>1) Be careful not to make scratch and molding damage!</p>
<p>1) Put the camera on the Braket.</p> 	<p>1) Put the speaker on the Braket.</p> 
<p>1) Be careful not to make scratch and molding damage! 2) Beware that you do not damage CAMERA F-PCB.</p>	<p>1) Arrange Speaker's WIRE not to be interfered with other components.</p>

5

1) Put the camera on the Braket.

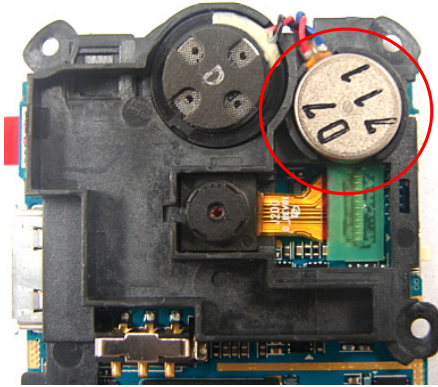

1) Arrange Motor's WIRE not to be interfered with other components.

6

1) Set KEYPAD on the Front.
.Check the KEYPAD's guide hole

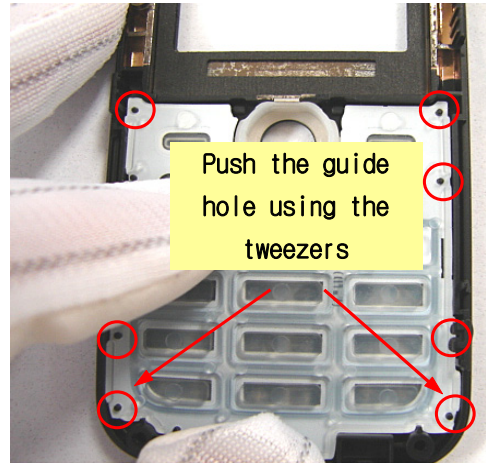

1) Be careful not to make scratch and molding damage!

7

1) Set a PBA on the FRONT.

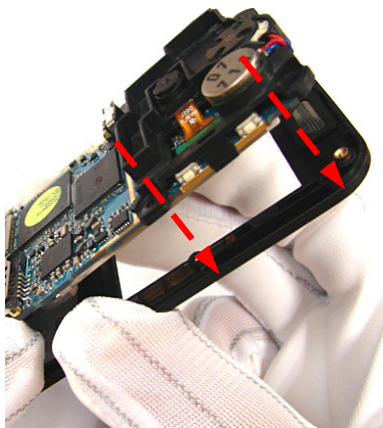

1) Be careful not to make scratch and molding damage!

8

1) Assemble REAR and FRONT ass'y



1) Be careful not to make scratch and molding damage!

9

1) Assemble the FRONT's hook 3point



- 1) Be careful not to make scratch and molding damage!
- 2) Check GAP is exist after finish assembly.

10

1) Drivers 6 screws on the REAR.

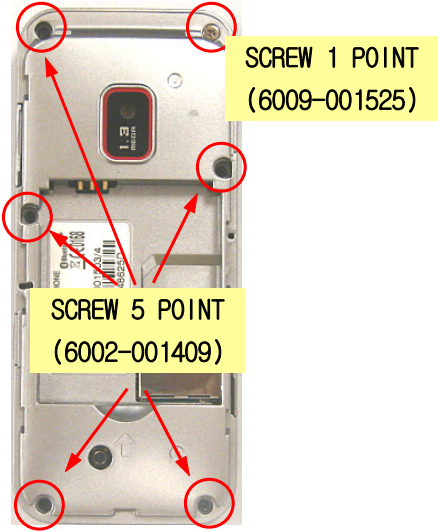

- 1) Be careful not to make scratch and molding damage!
- 2) 1 screw is different other screws.

